

Product Overview

NSM2019-Q0 is an integrated path current sensor with a very low on-resistance of 0.27mΩ, reducing heat loss on the chip.

NOVOSENSE innovative isolation technology and signal conditioning design can meet high isolation levels while sensing the current flowing through the internal Busbar. A differential Hall pair is used internally, so it has a strong immunity to external stray magnetic fields.

NSM2019-Q0 senses the magnetic field generated by the Busbar current flowing under the chip to indirectly detect the current. Compared with the current sampling method of the Shunt+ isolated op-amp, NSM2019-Q0 eliminates the need for the primary side power supply and has a simple and convenient layout. At the same time, it has extremely high isolation withstand voltage and Lifetime stability.

In high-side current monitoring applications, NSM2019-Q0 can reach a working voltage of 1618Vpk, and it can withstand 10kV surge voltage and 20kA surge current without adding any protection devices.

Due to NSM2019-Q0 internal accurate temperature compensation algorithm and factory accuracy calibration, this current sensor can maintain good accuracy in the full temperature working range, and the customer does not need to do secondary programming or calibration.

NSM2019-Q0 Provides overcurrent protect function.
Support 5V /3.3V power supply (different version)

Key Features

- High bandwidth and fast response time
- 320kHz bandwidth
- 1.5μs response time

- High-precision current measurement
- Differential Hall sets can immune stray field
- High isolation level that meets UL standards
- Working Voltage for Basic Isolation (VWVBI): 1618Vpk / 1144rms
- Withstand isolation voltage (VISO): 5000Vrms
- Maximum surge isolation withstand voltage (VIOSM): 10kV
- Maximum surge current (Isurge): 20kA
- CMTI > 100V/ns
- CTI (I)
- Creepage distance/Clearance distance: 8.2mm
- Fault Overcurrent Protection
- NOVOSENSE innovative 'Spin Current' technology makes offset temperature drift very small
- Fixed output with VREF
- Working temperature: -40°C ~ 150°C
- Primary internal resistance: 0.27mΩ
- Wide body SO10 package
- UL62368/EN62368 safety certification
- ROHS compliance
- AEC-Q100 Grade0

Applications

- Solar System
- Industrial Power Supply
- Motor Control
- OBC/DCDC/PTC Heater
- Charging Pile

Device Information

Part Number	Package	Body Size
NSM2019-Q0	SOW10	10.90×7.70×2.65mm

Functional Block Diagrams

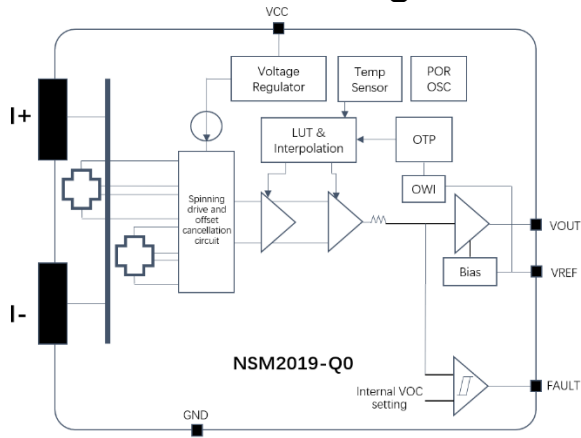

Figure 1. NSM2019-Q0 Block Diagram

INDEX

1. PIN CONFIGURATION AND FUNCTIONS	4
2. ABSOLUTE MAXIMUM RATINGS	4
3. ESD RATINGS	5
4. ISOLATION CHARACTERISTICS	5
5. SPECIFICATIONS	5
5.1. COMMON CHARACTERISTICS (TA= -40°C TO 150°C, VCC = 5V OR 3.3V, UNLESS OTHERWISE SPECIFIED)	5
5.2. NSM2019-80B3F1-Q0SWCR CHARACTERISTICS (TA= -40°C TO 150°C, VCC = 3.3V, UNLESS OTHERWISE SPECIFIED)	6
5.3. NSM2019-100B5F1-Q0SWCR CHARACTERISTICS (TA= -40°C TO 150°C, VCC = 5V, UNLESS OTHERWISE SPECIFIED)	8
6. TYPICAL PERFORMANCE CHARACTERISTICS	9
6.1. OVERVIEW	9
6.2. NSM2019-Q0 F VERSION(FIXED OUTPUT)	9
6.3. OVERCURRENT FAULT PERFORMANCE	9
6.4. DEFINITION OF NSM2019-Q0 TERMS	10
7. APPLICATION NOTE	13
7.1. TYPICAL APPLICATION CIRCUIT	13
7.2. PCB LAYOUT	13
7.3. THERMAL EVALUATION	14
8. PACKAGE INFORMATION	16
SOW10 PACKAGE	16
9. ORDERING INFORMATION	17
10. REVISION HISTORY	18

1. Pin Configuration and Functions

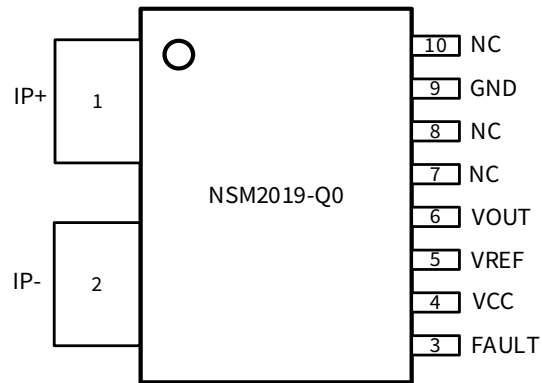

Figure 1.1 NSM2019-Q0 Package

Table 1.1 NSM2019-Q0 Pin Configuration and Description

NSM2019-Q0 PIN NO.	Symbol	Function
1	IP+	Current flows into the chip, positive direction
2	IP-	Current flows out of the chip, negative direction
3	FAULT	Overcurrent Fault, Active low, Open Drain Output
4	VCC	Power supply
5	VREF	Reference voltage output
6	VOUT	Output voltage
7	NC	Not connection, recommended connecting to GND
8	NC	Not connection, recommended connecting to GND
9	GND	Ground
10	NC	Not connection, recommended connecting to GND

2. Absolute Maximum Ratings

Parameters	Symbol	Min	Typ	Max	Unit	Comments
VCC	VCC	-0.3		6.5	V	25°C
Vout		-0.3		VCC+0.3	V	25°C
Others Pin		-0.3		VCC+0.3	V	25°C
Storage temperature	T _{Storage}	-40		150	°C	
Ambient temperature	T _{operation}	-40		150	°C	
Junction temperature		-40		150	°C	

3. ESD Ratings

Ratings		Value	Unit
Electrostatic discharge	Human body model (HBM), per AEC-Q100-002-RevD ● All pins	±8	kV
	Charged device model (CDM), per AEC-Q100-011-RevB ● All pins	±2	kV

4. Isolation Characteristics

Parameters	Symbol	Rating	Unit	Comments
Surge Voltage	V _{surge}	10	kV	Based on IEC61000-4-5 1.2μs /50μs waveform
Surge Current	I _{surge}	20	kA	Based on IEC61000-4-5 8μs /20μs waveform
Dielectric Strength Test Voltage	VISO	5000	V _{rms}	60s isolation voltage parameters, according to UL62368-1, 6kV/1s insulation performance will be tested before delivery
Working Voltage for Basic Isolation	VWVBI	1144	V _{rms}	Maximum approved working voltage for basic isolation according to UL60950-1 and UL62368-1
		1618	V _{dc}	
Common-mode transient immunity	CMTI	>100	V/ns	The criterion for judging the failure is that the output peak is greater than 100mV and the duration is longer than 1μs
Creepage	Creepage	8.2	mm	Minimum Creepage
Clearance	Clearance	8.2	mm	Minimum Clearance
Comparative Tracking Index	CTI	>=600		CTI I

5. Specifications

5.1. Common Characteristics (TA= -40°C to 150°C, VCC = 5V or 3.3V, unless otherwise specified)

Parameters	Symbol	Min	Typ	Max	Unit	Comments
Supply voltage	V _{CC}	3	3.3	3.6	V	3.3V version
		4.5	5	5.5	V	5V version
Supply current	I _{CC}		12	15	mA	No load, V _{CC} =5V
Primary conductor resistance	R _P		0.27		mΩ	TA = 25°C
Power-on time	T _{po}		1		ms	before 1ms internal OTP is loading, TA = 25°C
Output capacitance load ^{[1][2]}	C _L			10	nF	

Parameters	Symbol	Min	Typ	Max	Unit	Comments
Output resistance load ^{[1][2]}	R _L	10			kΩ	
Output short current	I _{short}			±30	mA	Short to VCC and short to GND, TA = 25°C
Rail to Rail output voltage ^{[1][2]}	V _s	0.1		VCC-0.1	V	TA = 25°C, CL=1nF, RL=10K to VCC or GND
Common mode field rejection ^{[1][2]}	CMFR		>40		dB	
Rise time ^{[1][2]}	T _r		1.2		μs	TA = 25°C, CL=1nF, VCC=5V
Propagation delay ^{[1][2]}	T _{pd}		1.2		μs	TA = 25°C, CL=1nF, VCC=5V
Response time ^{[1][2]}	T _{response}		1.5	3	μs	TA = 25°C, CL=1nF, VCC=5V
Bandwidth ^{[1][2]}	BW		320		kHz	-3dB bandwidth, TA = 25°C, CL=1nF, VCC=5V
Noise density ^{[1][2]}	ND		260		uArms/√Hz	TA = 25°C, CL=1nF, VCC= 5V
Non-linearity	E _{NL}		±0.2		%	
Reference voltage	V _{ref}	2.49	2.5	2.51	V	FB Version, Vcc=5V
		1.64	1.65	1.66	V	FB Version, Vcc=3.3V
		0.49	0.5	0.51	V	FU Version, Vcc=5V
		0.32	0.33	0.34	V	FU Version, Vcc=3.3V
Fault pull-up Resistance	R _{pu}	4.7		100	kΩ	
Overcurrent threshold	I _{ft}		100		%FS	Factory default value, other range can be customized by user
Fault Hysteresis	I _{hys}		10		%IPR	TA = 25°C, CL=1nF, I _{ft} threshold=100%IPR
Fault Response time	T _{fr}		1.5		μs	The time from Overcurrent happened to Fault pin active low, 4.7 kΩ pull-up Resistance
Fault Error			±8		%IPR	TA = 25°C, CL=1nF, I _{ft} threshold=100%IPR

[1]: Design by Guarantee

[2]: Guaranteed by Bench Validation

[3]: The increase or decrease of data in 5.X will not send a PCN to the customer if the evaluation does not affect the customer's use.

5.2. NSM2019-80B3F1-Q0SWCR Characteristics (TA= -40°C to 150°C, VCC = 3.3V, unless otherwise specified)

Parameters	Symbol	Min	Typ	Max	Unit	Comments
Current sensing range	I _{pr}	-80		80	A	
Sensitivity	Sens		16.5		mV/A	I _{prmin} <I _{pr} <I _{prmax}

Zero current output voltage	VQVO		1.65		V	I _{pr} =0A
Sensitivity error ^{[1][2]}	Esens	-2		2	%	TA = 25°C~150°C
		-2		2	%	TA = -40°C~25°C
Offset error ^[2]	VOE	-10		10	mV	TA = 25°C~150°C, I _{pr} =0A
		-10		10	mV	TA = -40°C~25°C, I _{pr} =0A
Reference error ^[2]	VRE	-10		10	mV	TA = 25°C~150°C, I _{pr} =0A, V _{ref} -1.65V
		-15		15	mV	TA = -40°C~25°C, I _{pr} =0A, V _{ref} -1.65V
Total output error ^[1]	Etotal	-2		2	%	TA = 25°C~150°C
		-2		2	%	TA = -40°C~25°C
Sensitivity error lifetime drift ^{[2][3]}	Esens_drif t	-2.5		2.5	%	After reliability test, TA = 25°C
Offset lifetime drift ^{[2][3]}	VOE_drift	-15		15	mV	After reliability test, TA = 25°C
Reference Lifetime drift ^{[2][3]}	VRE_drift	-15		15	mV	After reliability test, TA = 25°C
Total output error lifetime drift ^{[2][3]}	Etotal_drift	-2.8		2.8	%	After reliability test, TA = 25°C

[1]: In production, total error and sensitivity error are measured and calculated at 80A, A single part will not have both the maximum/minimum sensitivity error and maximum/minimum offset voltage.

[2]: Min/Max value is the mean value +/-3sigma. according to the statistical law, 99.73% of the data is in this range Inside.

[3]: The reliability data is implemented in accordance with the AEC-Q100 standard. This item is derived from the experimental results with the largest change after the PC, HTS, HAST, UHAST, HTOL, TC and other test data required by AEC-Q100 Grade0 as a reference and it is the worst case.

5.3. NSM2019-100B5F1-Q0SWCR Characteristics (TA= -40°C to 150°C, VCC = 5V, unless otherwise specified)

Parameters	Symbol	Min	Typ	Max	Unit	Comments
Current sensing range	Ipr	-100		100	A	
Sensitivity	Sens		20		mV/A	Iprmin<Ipr<Iprmax
Zero current output voltage	VQVO		2.5		V	Ipr=0A
Sensitivity error ^{[1][2]}	Esens	-2		2	%	TA = 25°C~150°C
		-2		2	%	TA = -40°C~25°C
Offset error ^[2]	VOE	-10		10	mV	TA = 25°C~150°C, Ipr=0A
		-10		10	mV	TA = -40°C~25°C, Ipr=0A
Reference error ^[2]	VRE	-10		10	mV	TA = 25°C~150°C, Ipr=0A, Vref=2.5V
		-15		15	mV	TA = -40°C~25°C, Ipr=0A, Vref=2.5V
Total output error ^[1]	Etotal	-2		2	%	TA = 25°C~150°C
		-2		2	%	TA = -40°C~25°C
Sensitivity error lifetime drift ^{[2][3]}	Esens_drift	-2.5		2.5	%	After reliability test, TA = 25°C
Offset lifetime drift ^{[2][3]}	VOE_drift	-15		15	mV	After reliability test, TA = 25°C
Reference Lifetime drift ^{[2][3]}	VRE_drift	-15		15	mV	After reliability test, TA = 25°C
Total output error lifetime drift ^{[2][3]}	Etotal_drift	-2.8		2.8	%	After reliability test, TA = 25°C

[1]: In production, total error and sensitivity error are measured and calculated at 100A, A single part will not have both the maximum/minimum sensitivity error and maximum/minimum offset voltage.

[2]: Min/Max value is the mean value +/-3sigma. according to the statistical law, 99.73% of the data is in this range Inside.

[3]: The reliability data is implemented in accordance with the AEC-Q100 standard. This item is derived from the experimental results with the largest change after the PC, HTS, HAST, UHAST, HTOL, TC and other test data required by AEC-Q100 Grade0 as a reference and it is the worst case.

In the chapter 5, the increase or decrease of the material number and the tightening of the parameter range, NOVOSENSE reserves the right not to send PCN to the customer, unless the expansion of the parameter range affects the customer's use and product performance.

6. Typical Performance Characteristics

6.1. Overview

NSM2019-Q0 current sensor can accurately measure AC/DC current while minimizing the overall measurement cost. Current sensors based on the Hall principle can be widely used in all current monitoring applications such as consumption, industry, and automotive. Compared with current transformers, the extremely small size of NSM2019-Q0 SOW10 can help customers reduce the overall PCB area; compared to Shunt + isolated op amps, NSM2019-Q0 only needs low-voltage side power supply, reducing the inconvenience of isolated op amps requiring power supply for both high and low voltages. When using NSM2019-Q0, you only need to string the primary side pin into the measured current. According to the part of Maxwell equations about electricity and magnetism, a magnetic field will be generated around the energized conductor of the primary side. The Hall and conditioning amplifier circuits in NSM2019-Q0 will convert magnetic field into an output voltage, and the output voltage increases or decreases in proportion to the input current.

Benefiting from the typical value of the primary resistance of NSM2019-Q0 is only 0.27mohm, as long as the customer conducts a reasonable heat dissipation design, the temperature rise brought by the measurement of large current can be effectively reduced.

At the same time, NSM2019-Q0 uses dual Hall sampling internally, the common mode magnetic field brought by the outside world can be effectively reduced. According to the measured typical value, if the 100G common mode magnetic field acts vertically on the chip, it will only bring an error of less than 1G in the output. (Equivalent to input). Because NSM2019-Q0 has a good ability to resist common-mode magnetic fields, it can still maintain excellent performance in motor control or some harsh current measurement environments.

6.2. NSM2019-Q0 F Version(fixed output)

In some applications, the ADC and the current sensor do not share a power rail, so the sensor needs to have absolute sensitivity that does not vary with the power supply voltage. The value of the sensing current can be obtained by $(V_{out} - V_{ref}) / \text{Sensitivity}$. For $\pm 50A$ measurement range, if V_{out} measures 3.7V and V_{REF} measures 2.5V, then the input current is $(3.7V - 2.5V) / 40mV/A = 30A$. In practical applications, V_{out} and V_{REF} can be directly collected by differential ADC to obtain input current, and the measurement accuracy will not be affected by power supply changes.

6.3. Overcurrent Fault Performance

NSM2019-Q0 has overcurrent protect function. When the primary current exceeds the overcurrent threshold, the internal error comparator reverses, driving Open Drain Output to work, and the Fault pin is pulled down.

The factory default overcurrent threshold for NSM2019-Q0 is 100%FS.

Other ranges can be customized as required. The optional ranges of overcurrent threshold as follow:

Parameters	Range(%FS)
Overcurrent Threshold	75
	100
	125
	150
	175
	200

Overcurrent Fault is triggered when the primary current (positive or negative current) exceeds the overcurrent threshold . Fault is cleared when the absolute value of the primary current is less than the current threshold set minus current hysteresis. Tfr is Fault Response time : the time from the primary current meets the overcurrent condition to Fault pin is pulled down. The timing of overcurrent protection is as follows:

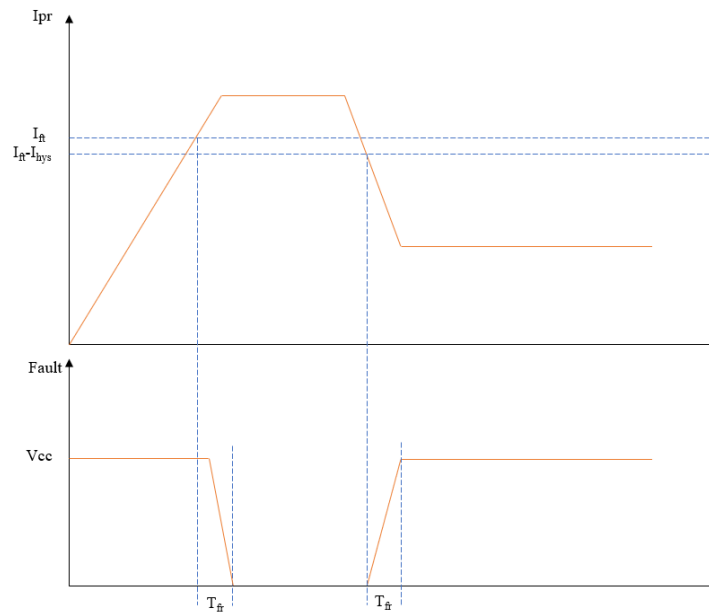

Figure 6.1 NSM2019-Q0 Overcurrent Performance

6.4. Definition of NSM2019-Q0 Terms

Power-on Time (Tpo)

When the power supply climbs from 0 to the chip's working range, NSM2019-Q0 needs some time to establish the internal working logic. Tpo time is defined as: the time from the power supply climbing to Vccmin to the output reaching the steady state within ±10%, As shown below:

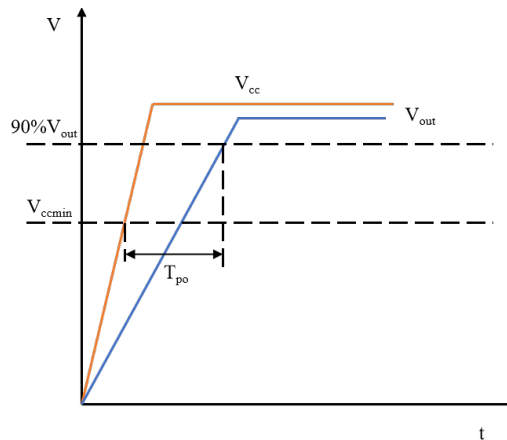

Figure 6.2 NSM2019-Q0 Power-on time

Rise Time (Tr)

The time from 10% to 90% of the output signal is defined as the output rise time. For step input signals, there is such an approximate relationship between the rise time and bandwidth of the output signal: $f(-3dB) = 0.35/Tr$.

Propagation Delay (Tpd)

The time from 20% of the primary current to 20% of the output signal is defined as the output propagation delay time.

Response Time (Tresponse)

The time from 90% of the primary current to 90% of the output signal is defined as the output response time.

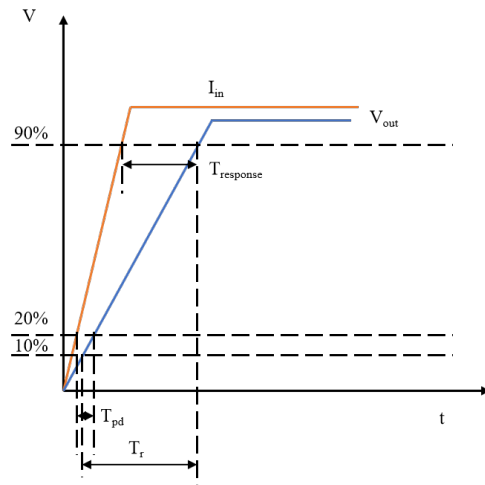

Figure 6.3 NSM2019-Q0 response time

Sensitivity and Sensitivity Error

Sensitivity is defined as the ratio of the output voltage proportional to the primary input current. Sensitivity is the slope of the curve in the figure below.

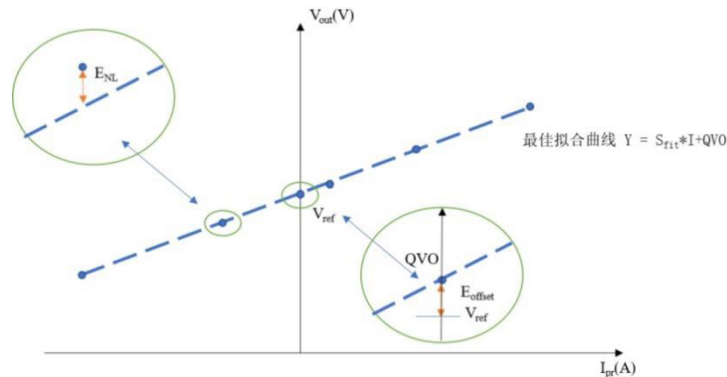

Figure 6.4 NSM2019-Q0 Sensitivity and error

The sensitivity error is defined as the deviation between the slope of the best-fit curve and the slope of the ideal curve. The slope of the best-fit curve comes from the measured value:

$$E_{sens} = \frac{(S_{fit} - S_{ideal})}{S_{ideal}} * 100\%$$

Offset Error

The zero current output error is defined as the difference between the output voltage and the reference voltage when the primary current is 0A, Vref here is VCC/2 or 0.1*VCC (R version):

$$E_{offset} = QVO - V_{ref}$$

Nonlinear Error

The linearity error is defined as the error from the maximum deviation point of the best-fit curve to the full scale. The mathematical expression is as follows:

$$V_{NL} = V_{outmax} - (S_{fit} * I_{max} + QVO)$$

among them:

Voutmax is the output voltage furthest from the fitted curve;

Imax is the primary current furthest from the fitted curve;

Therefore, the nonlinear error can be mathematically expressed as the following formula:

$$E_{NL} = \frac{V_{NL}}{FS} * 100\%$$

Total Error

The total error is defined as the error between the actual given current and the current measured by the chip, in other words, the difference between the actual output voltage and the ideal output voltage. It should be known that in different current ranges, the factors that dominate the total error are different. If it is under low current measurement, the zero point error is the main source of error; if under high current measurement, the total error caused by the zero point error is very small, and the dominant error is the sensitivity error.

$$E_{total}(I_{pr}) = \frac{V_{out_{ideal}}(I_{pr}) - V_{out}(I_{pr})}{FS}$$

7. Application Note

7.1. Typical Application Circuit

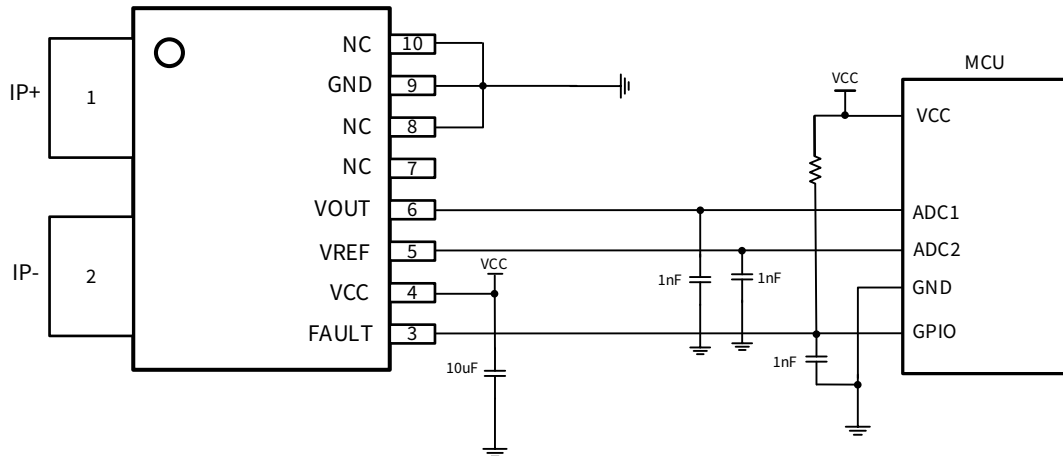

Figure 7.1 Typical Application Diagram

7.2. PCB Layout

For NSM2019-Q0 in high-current monitoring applications, a reasonable layout will make the system heat dissipation faster and better. The copper area on the NSM2019-Q0 Demo board is 30mm*28mm (very small copper area is used to illustrate the worse situation, rather than a large copper area), the top layer and the bottom layer are 4oz copper thick. If customers want to achieve better heat dissipation, they can use multi-layer boards and thicken the copper thickness to achieve it, and can use active heat dissipation solutions in the system, such as adding heat sinks and fans. If you need to use the NSM2019-Q0 Demo board to evaluate the performance of this current sensor, please contact NOVOSENSE sales team for support.

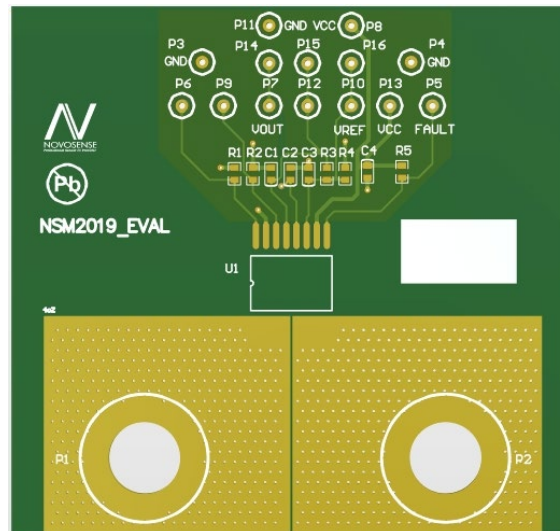

Figure 7.2 NSM2019-Q0 PCB Layout

7.3. Thermal Evaluation

The thermal evaluation experiment is tested at room temperature, which mainly illustrates the temperature rise of the NSM2019-Q0 current sensor under different currents. With these data and the above-mentioned layout guide, customers can design heat dissipation according to actual application requirements. The ambient temperature in this experiment is room temperature. The surface is mounted on the above Demo board for temperature rise test. There is no external active heat dissipation device (such as a fan, etc.). The relationship between junction temperature and time is measured. 10 minutes of temperature data are collected. Under normal circumstances, the temperature rise It is basically fixed in about 10 minutes, and the specific test data are as follows:

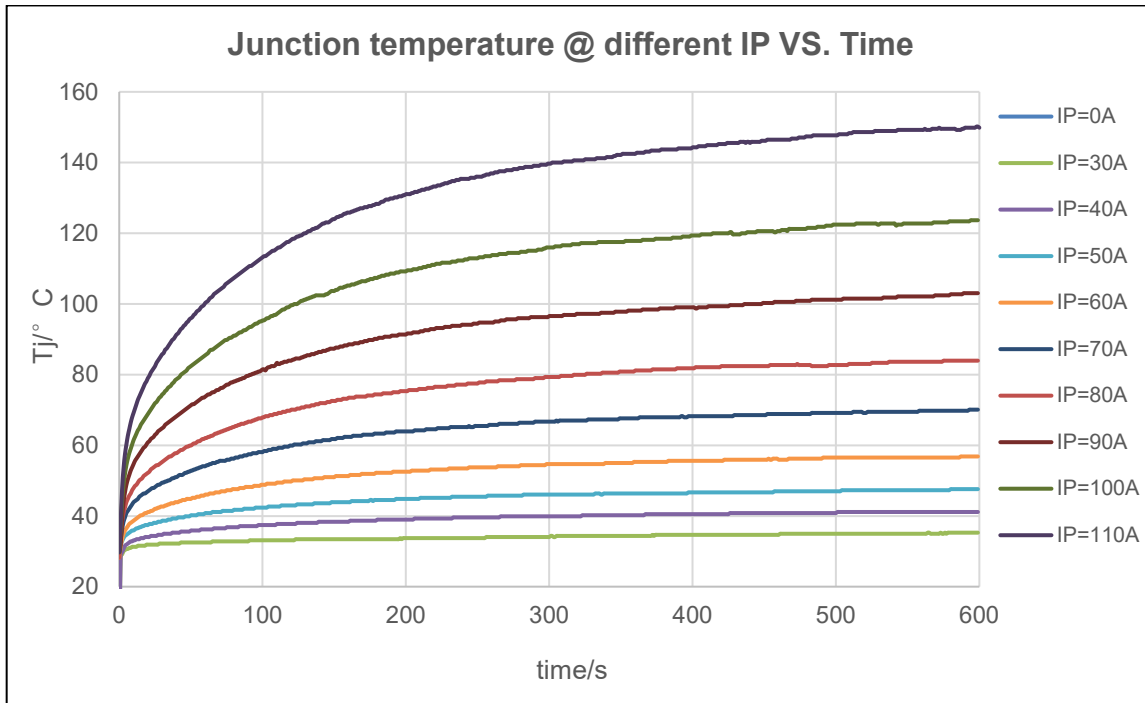

Figure 7.3 NSM2019-Q0 Junction temperature vs. Different continues current

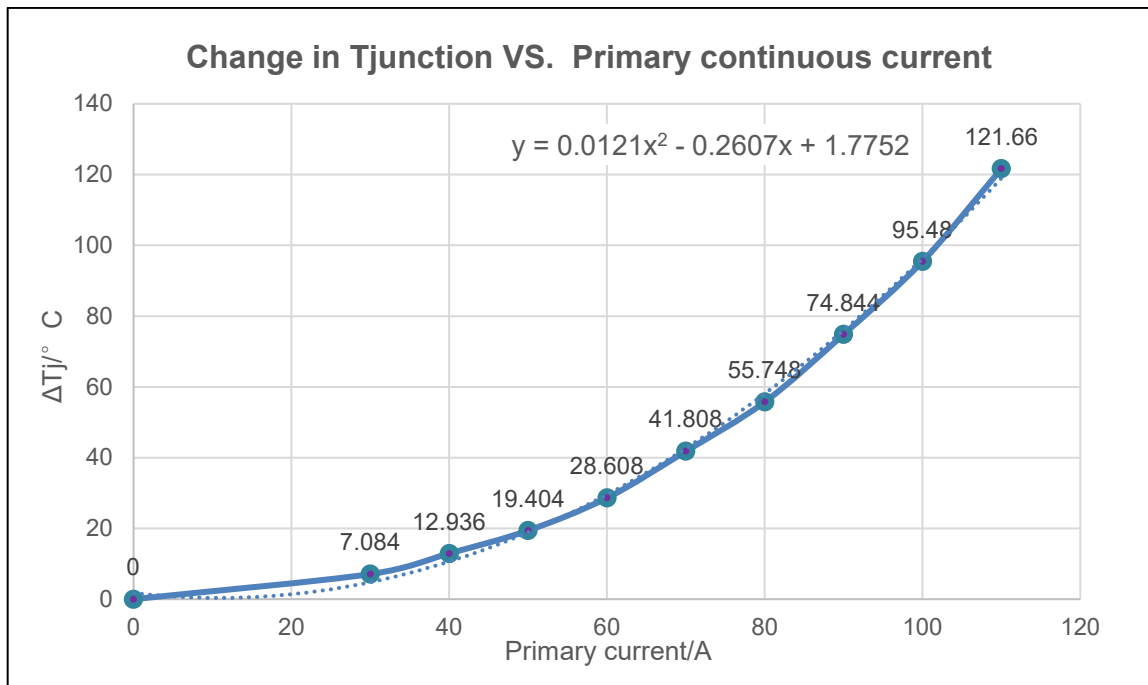

Figure 7.4 NSM2019-Q0 Estimation function of junction temperature at different currents (PCB is in the worst case)

It is important to note that the above temperature rise experiment data is only based on the Demo board, to reflect the relationship between NSM2019-Q0 current and temperature in a worst case. Customers can reduce the temperature rise

of T_j by increasing or thickening the copper area of the PCB, using multi-layer boards, or adding active heat dissipation devices such as fans ($T_j < 150^\circ\text{C}$). If customers compare NSM2019-Q0 with other competing products, please refer to the same PCB design instead of using specially designed PCB provided by competing products. NOVOSENSE can provide SOW10 general-purpose Demo board for comparison of temperature rises of competing products.

8. Package Information

SOW10 Package

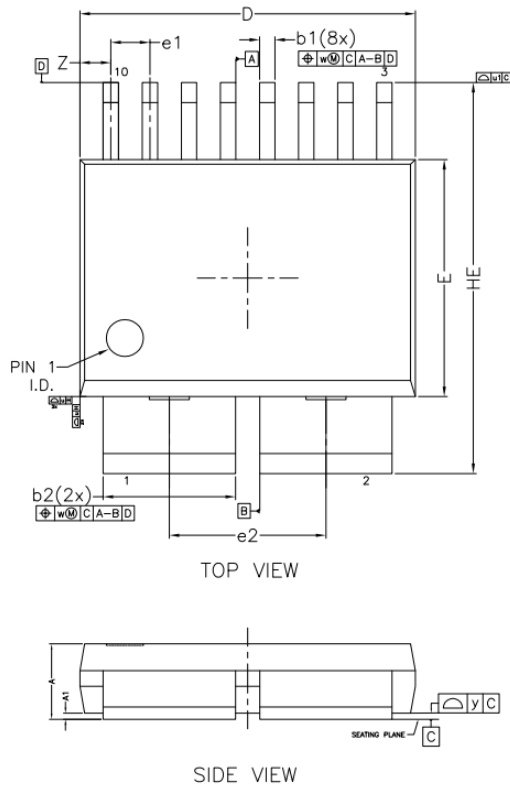

* CONTROLLING DIMENSION : MM

SYMBOL	MM		
	MIN.	NOM.	MAX.
A	---	---	2.65
A1	0.10	---	0.30
A2	2.18	2.25	2.32
b1	0.45	---	0.55
b2	4.25	---	4.35
c	0.508 REF.		
D	10.8	10.9	11.0
E	7.60	7.70	7.80
HE	12.5	12.7	12.9
Q1	0.845	0.87	0.895
Q2	0.845	0.87	0.895
e1	1.27 BSC		
e2	5.09 BSC		
A3	0.25 REF		
L	2.50 REF		
Lp	0.40	---	2.00
y	0.15		
u	0.10		
u1	0.20		
w	0.15		
Z	1.005		
θ	0°	---	8°

NOTES:
 1.0 COPLANARITY APPLIES TO LEADS, CORNER LEADS AND DIE ATTACH PAD.
 2.0 PLASTIC OR METAL PROTRUSIONS OF 0.15MM MAXIMUM PER SIDE ARE NOT INCLUDED

Figure 8.1 SOW10 Package Shape and Dimension in millimeters and (inches)

9. Ordering Information

Part Number	Primary Current(A)	Power Supply(V)	Sensitivity (Mv/A)	Overcurrent Threshold (%)	MSL	MPQ	Package
NSM2019- 80B3F1-Q0SWCR	±80	3.3	16.5	100%	3	1k	SOW10
NSM2019- 100B5F1-Q0SWCR	±100	5	20	100%	3	1k	SOW10

Part Number Rule:

NSM2019-50B5FX-Q0SWCR

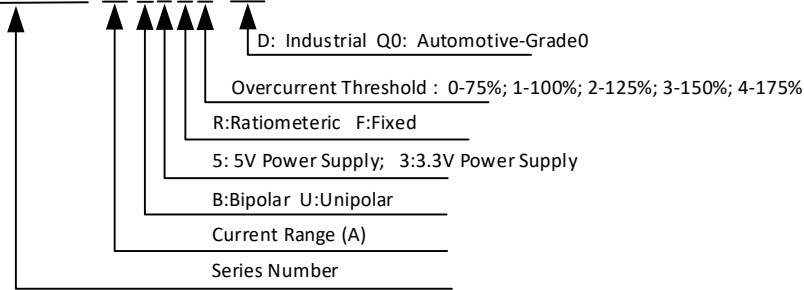

10. Revision History

Revision	Description	Date
1.0	Release 1.0 version	2024/12/08

IMPORTANT NOTICE

The information given in this document (the "Document") shall in no event be regarded as any warranty or authorization of, express or implied, including but not limited to accuracy, completeness, merchantability, fitness for a particular purpose or infringement of any third party's intellectual property rights.

Users of this Document shall be solely responsible for the use of NOVOSENSE's products and applications, and for the safety thereof. Users shall comply with all laws, regulations and requirements related to NOVOSENSE's products and applications, although information or support related to any application may still be provided by NOVOSENSE.

This Document is provided on an "AS IS" basis, and is intended only for skilled developers designing with NOVOSENSE's products. NOVOSENSE reserves the rights to make corrections, modifications, enhancements, improvements or other changes to the products and services provided without notice. NOVOSENSE authorizes users to use this Document exclusively for the development of relevant applications or systems designed to integrate NOVOSENSE's products. No license to any intellectual property rights of NOVOSENSE is granted by implication or otherwise. Using this Document for any other purpose, or any unauthorized reproduction or display of this Document is strictly prohibited. In no event shall NOVOSENSE be liable for any claims, damages, costs, losses or liabilities arising out of or in connection with this Document or the use of this Document.

For further information on applications, products and technologies, please contact NOVOSENSE (www.novosns.com).

Suzhou NOVOSENSE Microelectronics Co., Ltd