

## Product Overview

NSI83085C is a high reliability isolated half duplex RS-485 transceiver based on NOVOSENSE digital isolation technology. The NSI83085C is safety certified by UL1577 support 5kV<sub>rms</sub> insulation withstand voltages, while providing high electromagnetic immunity and low emissions at low power consumption.

The Bus pins of NSI83085C is protected from ±10kV system level ESD to GND2 on Bus side. The device feature fail-safe circuitry, which guarantees a logic-high receiver output when the receiver inputs are open or shorted. The device has a 1/8-unit-load receiver input impedance that allows up to 256 transceivers on the bus.

The data rate of NSI83085C is 12Mbps. The device is slew limited to reduce EMI and reflections with improperly terminated transmission line.

## Key Features

- Up to 5000V<sub>rms</sub> Insulation voltage
- Bus side power supply voltage: 3.0V to 5.5V
- VDD1 supply voltage: 2.5V to 5.5V
- High CMTI: ±150kV/μs
- High system level EMC performance:  
Bus Pins meet IEC61000-4-2 ±10kV ESD
- Fail-safe protection receiver
- Up to 256 transceivers on the bus
- Operation temperature: -40°C ~105°C
- RoHS-compliant packages:  
SOW16

## Safety Regulatory Approvals

- UL recognition: up to 5000V<sub>rms</sub> for 1 minute per UL1577
- CQC certification per GB4943.1
- CSA component notice 5A approval IEC60950-1 standard
- DIN EN IEC 60747-17 (VDE 0884-17)

## Applications

- Industrial automation system
- Isolated RS-485 communication
- Smart electric meter and water meter
- Security and protection monitoring

## Device Information

Part Number	Package	Body Size
NSI83085C-DSWR	SOP16(300mil)	10.30mm × 7.50mm

## Functional Block Diagrams

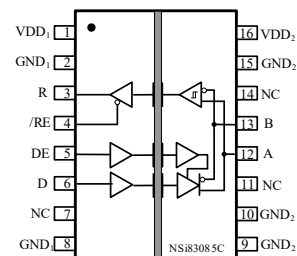

Figure 1. NSI83085C Block Diagrams

# INDEX

<b>1. PIN CONFIGURATION AND FUNCTIONS .....</b>	<b>3</b>
<b>2. ABSOLUTE MAXIMUM RATINGS .....</b>	<b>4</b>
<b>3. ESD RATINGS .....</b>	<b>4</b>
<b>4. THERMAL INFORMATION.....</b>	<b>4</b>
<b>5. SPECIFICATIONS .....</b>	<b>5</b>
5.1. DC ELECTRICAL CHARACTERISTICS.....	5
5.2. SWITCHING ELECTRICAL CHARACTERISTICS.....	7
5.3. TYPICAL PERFORMANCE CHARACTERISTICS.....	8
5.4. PARAMETER MEASUREMENT INFORMATION.....	9
<b>6. HIGH VOLTAGE FEATURE DESCRIPTION .....</b>	<b>12</b>
6.1. INSULATION AND SAFETY RELATED SPECIFICATIONS .....	12
6.2. INSULATION CHARACTERISTICS.....	12
6.3. SAFETY-LIMITING VALUES.....	13
6.4. REGULATORY INFORMATION .....	14
<b>7. FUNCTION DESCRIPTION .....</b>	<b>15</b>
7.1. DATA RATE .....	15
7.2. TRUE FAIL-SAFE RECEIVER INPUTS.....	15
7.3. TRUTH TABLES.....	15
7.4. THERMAL SHUTDOWN .....	16
<b>8. APPLICATION NOTE.....</b>	<b>16</b>
8.1. 256 TRANSCEIVERS ON THE BUS .....	16
8.2. ESD PROTECTION .....	16
8.3. LAYOUT CONSIDERATIONS.....	16
8.4. TYPICAL APPLICATION .....	17
<b>9. PACKAGE INFORMATION .....</b>	<b>18</b>
<b>10. ORDER INFORMATION.....</b>	<b>19</b>
<b>11. TAPE AND REEL INFORMATION .....</b>	<b>20</b>
<b>12. REVISION HISTORY .....</b>	<b>22</b>

# 1. Pin Configuration and Functions

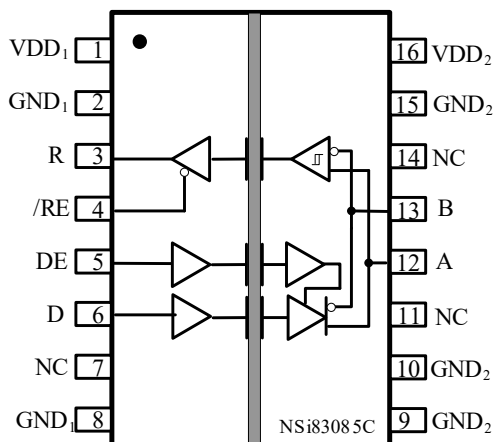

Figure 1.1 NSI83085C Package

Table 1.1 NSI83085C Pin Configuration and Description

NSI83085C PIN NO.	SYMBOL	FUNCTION
1	VDD <sub>1</sub>	Power Supply for Isolator Side 1
2	GND <sub>1</sub>	Ground 1, the ground reference for Isolator Side 1
3	R	Receive output
4	/RE	Receive enable input. This is an active low input.
5	DE	Driver enable input. This is an active high input
6	D	Driver transmit data input.
7	NC	No Connection.
8	GND <sub>1</sub>	Ground 1, the ground reference for Isolator Side 1
9	GND <sub>2</sub>	Ground 2, the ground reference for Isolator Side 2
10	GND <sub>2</sub>	Ground 2, the ground reference for Isolator Side 2
11	NC	No Connection.
12	A	Noninverting Driver Output/Receiver Input. When the driver is disabled, or when VDD <sub>1</sub> or VDD <sub>2</sub> is powered down, Pin A is put into a high impedance state to avoid overloading the bus.
13	B	Inverting Driver Output/Receiver Input. When the driver is disabled, or when VDD <sub>1</sub> or VDD <sub>2</sub> is powered down, Pin B is put into a high impedance state to avoid overloading the bus.
14	NC	No Connection.
15	GND <sub>2</sub>	Ground 2, the ground reference for Isolator Side 2
16	VDD <sub>2</sub>	Power Supply for Isolator Side 2

## 2. Absolute Maximum Ratings

Parameters	Symbol	Min	Typ	Max	Unit	Comments
Power Supply Voltage	VDD <sub>1</sub> , VDD <sub>2</sub>	-0.5		6	V	
Maximum Input Voltage	/RE, DE, D	-0.4		VDD+0.4	V	
Driver Output/Receiver Input Voltage	VA, VB	-7		12	V	
Differential input voltage, A with respect to B	V <sub>ID</sub>	-18		18	V	
Voltage input, transient pulse (through 100Ω)	V <sub>IT</sub>	-30		30	V	A, B
Receiver Output Current	I <sub>O</sub>	-15		15	mA	
Maximum Surge Isolation Voltage	V <sub>IOSM</sub>			6.25	kV	
Operating Temperature	T <sub>opr</sub>	-40		105	°C	
Junction Temperature	T <sub>J</sub>	-40		150	°C	
Storage Temperature	T <sub>stg</sub>	-65		150	°C	

## 3. ESD Ratings

Ratings		Value	Unit
Electrostatic discharge	Human body model (HBM), per AEC-Q100-002-RevD		
	<ul style="list-style-type: none"> <li>All pins</li> </ul>	± 6000	V
	<ul style="list-style-type: none"> <li>Bus pins and GND</li> </ul>	± 8000	V
Charged device model (CDM), per AEC-Q100-011-RevB			
	<ul style="list-style-type: none"> <li>All pins</li> </ul>	± 2000	V

## 4. Thermal Information

Parameters	Symbol	SOP16(300mil)	Unit
IC Junction-to-Air Thermal Resistance	θ <sub>JA</sub>	67.9	°C/W
Junction-to-case (top) thermal resistance	θ <sub>JC (top)</sub>	27.7	°C/W
Junction-to-board thermal resistance	θ <sub>JB</sub>	29.4	°C/W

## 5. Specifications

### 5.1. DC Electrical Characteristics

(VDD1=2.5V~5.5V, VDD2=3.0V~5.5V, TA=-40°C to 105°C. Unless otherwise noted, Typical values are at VDD1 = 5V, VDD2 = 5V, TA = 25°C)

Parameters	Symbol	Min	Typ	Max	Unit	Comments
Power supply voltage	VDD1	2.5		5.5	V	
	VDD2	3.0		5.5	V	Bus Side
Logic-side supply current	IDD1		2.97	4.98	mA	VDD1=5V, DE=high, /RE=D=low, no load
			2.94	4.89	mA	VDD1=3V, DE=high, /RE=D=low, no load
Bus-side supply current	IDD2		2.83	5.02	mA	VDD2=5V, DE=high, /RE=D=low, no load (NSI83085C)
Thermal-Shutdown Threshold	T <sub>TS</sub>		165		°C	
Thermal-Shutdown Hysteresis	T <sub>TSH</sub>		15		°C	
Common Mode Transient Immunity	CMTI	±100	±150		kV/μs	
<b>Logic Side</b>						
Input High Voltage	V <sub>IH</sub>	2			V	DE, D,
		0.7*VDD1				/RE
Input Low Voltage	V <sub>IL</sub>			0.8	V	DE, D
				0.3*VDD1		/RE
Input Pull up Current	I <sub>PU</sub>			20	μA	DE, /RE
Input Pull down Current	I <sub>PD</sub>	-20			μA	DI
Output Voltage High	V <sub>OH</sub>	VDD1-0.3			V	I <sub>OH</sub> = -4mA
Output Voltage Low	V <sub>OL</sub>			0.3	V	I <sub>OL</sub> = 4mA
Output Short-Circuit Current	I <sub>OSR</sub>			150	mA	0 ≤ V <sub>R</sub> ≤ VDD1
Three-State Output Current	I <sub>OZ</sub>	-15			μA	0 ≤ V <sub>R</sub> ≤ VDD1, /RE = high
Input Capacitance	C <sub>IN</sub>		2		pF	DE, D, /RE
<b>Driver</b>						
Differential Output Voltage	V <sub>OD</sub>			VDD2	V	No Load
		2.7		VDD2	V	<a href="#">See Figure 5.7</a> , R <sub>L</sub> =100Ω (RS-422), VDD2=5V

		1.5		VDD2	V	See Figure 5.7, $R_L=100\Omega$ (RS-422), VDD2=3.3V
		2.1		VDD2	V	See Figure 5.7, $R_L=54\Omega$ (RS-485), VDD2=5V
		1.3		VDD2	V	See Figure 5.7, $R_L=54\Omega$ (RS-485), VDD2=3.3V
Change in magnitude of the differential output voltage	$\Delta V_{OD} $			0.2	V	See Figure 5.7, $R_L=100\Omega$ or $R_L=54\Omega$
Common-Mode Output Voltage	$ V_{OC} $		VDD <sub>2</sub> /2	3.5	V	See Figure 5.7, $R_L=100\Omega$ or $R_L=54\Omega$
Change in Magnitude of Common-Mode Voltage	$\Delta V_{OC} $			0.2	V	See Figure 5.7, $R_L=100\Omega$ or $R_L=54\Omega$
Driver Short-Circuit Output Current	$I_{OSD}$			250	mA	$0 \leq V_{OUT} \leq +12V$
		-250			mA	$-7V \leq V_{OUT} \leq VDD_2$
Output Leakage Current	$I_o$			200	$\mu A$	DE=GND, VIN=12V
		-150			$\mu A$	DE=GND, VIN=-7V
<b>Receiver</b>						
Input Current (A and B)	$I_A, I_B$			200	$\mu A$	DE=GND, VDD <sub>2</sub> =GND, VIN=12V
		-200			$\mu A$	DE=GND, VDD <sub>2</sub> =GND, VIN=-7V
Receiver Differential Threshold Voltage	$V_{TH}$	-200	-125	-10	mV	$-7V \leq V_{CM} \leq 12V$
Receiver Input Hysteresis	$\Delta V_{TH}$		15		mV	$V_A+V_B=0$
Receiver Input Resistance	$R_{IN}$	96			k $\Omega$	$-7V \leq V_{CM} \leq 12V$ , DE=low

**5.2. Switching Electrical Characteristics**

(VDD1=2.5V~5.5V, VDD2=3.0V~5.5V, T<sub>A</sub>=-40°C to 105°C. Unless otherwise noted, Typical values are at VDD1 = 5V, VDD2 = 5V, T<sub>A</sub> = 25°C)

Parameters	Symbol	Min	Typ	Max	Unit	Comments
<b>Driver (NSI83085C)</b>						
Maximum Data Rate	f <sub>MAX</sub>	12			Mbps	
Driver Propagation Delay	t <sub>PLH</sub>		30	50	ns	<a href="#">See Figure 5.8, R<sub>L</sub>=54Ω, C<sub>L</sub>=50pF</a>
	t <sub>PHL</sub>		30	50	ns	<a href="#">See Figure 5.8, R<sub>L</sub>=54Ω, C<sub>L</sub>=50pF</a>
Driver Pulse Width Distortion,  t <sub>PHL</sub> - t <sub>PLH</sub>	PWD		1	10	ns	<a href="#">See Figure 5.8, R<sub>L</sub>=54Ω, C<sub>L</sub>=50pF</a>
Driver Output Falling Time or Rising time	t <sub>F</sub>		8	16	ns	<a href="#">See Figure 5.8, R<sub>L</sub>=54Ω, C<sub>L</sub>=50pF</a>
	t <sub>R</sub>		7	14	ns	<a href="#">See Figure 5.8, R<sub>L</sub>=54Ω, C<sub>L</sub>=50pF</a>
Driver Enable to Output High	t <sub>ZH</sub>		17.2	60	ns	<a href="#">See Figure 5.9, R<sub>L</sub>=110Ω, C<sub>L</sub>=50pF</a>
Driver Enable to Output Low	t <sub>ZL</sub>		26.8	60	ns	<a href="#">See Figure 5.9, R<sub>L</sub>=110Ω, C<sub>L</sub>=50pF</a>
Driver Output High to Disable	t <sub>HZ</sub>		17	60	ns	<a href="#">See Figure 5.9, R<sub>L</sub>=110Ω, C<sub>L</sub>=50pF</a>
Driver Output Low to Disable	t <sub>LZ</sub>		24	60	ns	<a href="#">See Figure 5.9, R<sub>L</sub>=110Ω, C<sub>L</sub>=50pF</a>
<b>Receiver (NSI83085C)</b>						
Maximum Data Rate	f <sub>MAX</sub>	12			Mbps	
Receiver Propagation Delay	t <sub>PLH</sub>		76	120	ns	<a href="#">See Figure 5.10, C<sub>L</sub>=15pF</a>
	t <sub>PHL</sub>		78	120	ns	<a href="#">See Figure 5.10, C<sub>L</sub>=15pF</a>
Receiver Pulse Width Distortion,  t <sub>PHL</sub> - t <sub>PLH</sub>	PWD		4	25	ns	<a href="#">See Figure 5.10, C<sub>L</sub>=15pF</a>
Receiver Output Falling Time or Rising time	t <sub>F</sub>		2.4	5	ns	<a href="#">See Figure 5.10, C<sub>L</sub>=15pF</a>
	t <sub>R</sub>		3.4	7	ns	<a href="#">See Figure 5.10, C<sub>L</sub>=15pF</a>

Receiver Enable to Output High	$t_{ZH}$		16	60	ns	<a href="#">See Figure 5.11, <math>R_L=1k\Omega, C_L=15pF</math></a>
Receiver Enable to Output Low	$t_{ZL}$		16	60	ns	<a href="#">See Figure 5.11, <math>R_L=1k\Omega, C_L=15pF</math></a>
Receiver Disable to Output High	$t_{HZ}$		17	60	ns	<a href="#">See Figure 5.11, <math>R_L=1k\Omega, C_L=15pF</math></a>
Receiver Disable to Output Low	$t_{LZ}$		14	60	ns	<a href="#">See Figure 5.11, <math>R_L=1k\Omega, C_L=15pF</math></a>

5.3. Typical Performance Characteristics

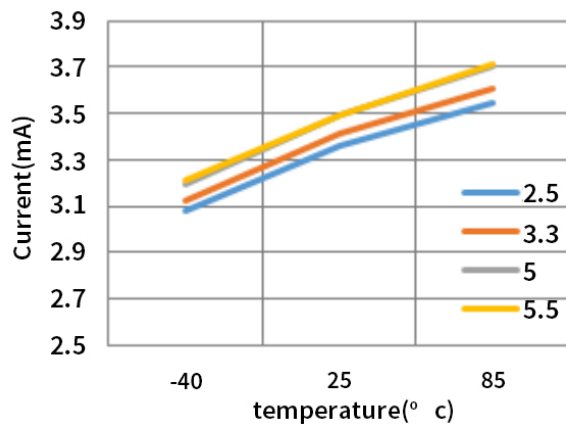

Figure 5.1 VDD1 supply current vs Temperature

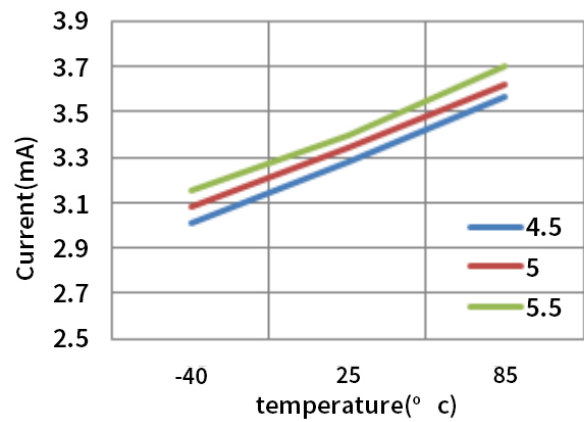

Figure 5.2 VDD2 supply current vs Temperature

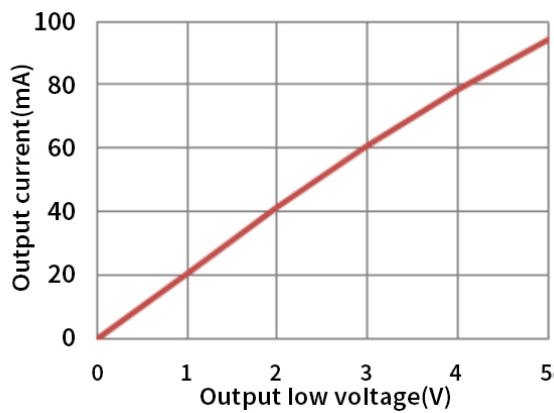

Figure 5.3 Receiver output current vs Output low voltage

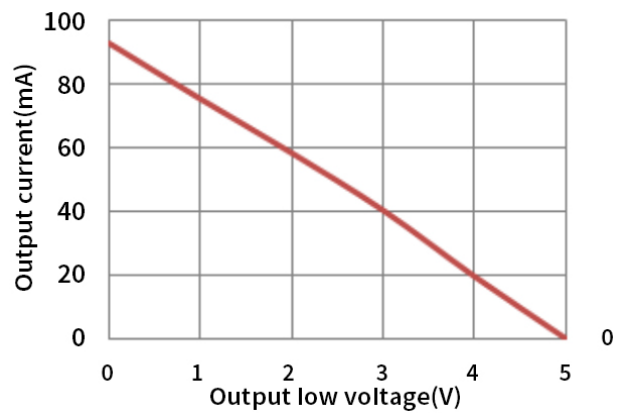

Figure 5.4 Receiver output current vs Output High voltage

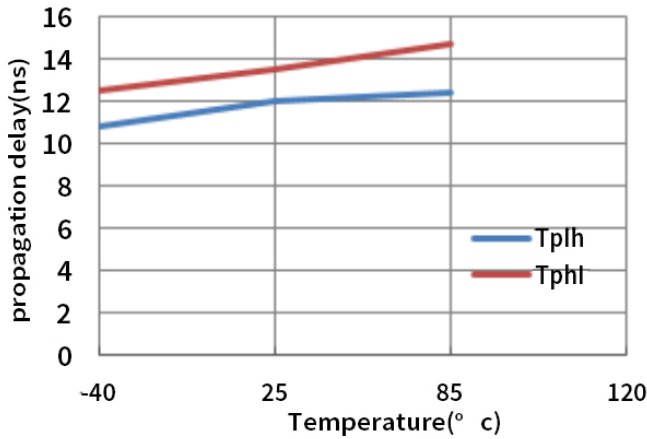

Figure 5.5 Transmitter Propagation Delay vs Temperature

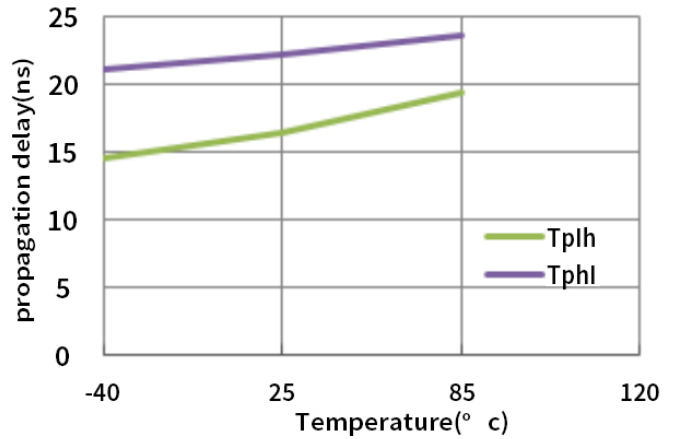

Figure 5.6 Receiver Propagation Delay vs Temperature

### 5.4. Parameter Measurement Information

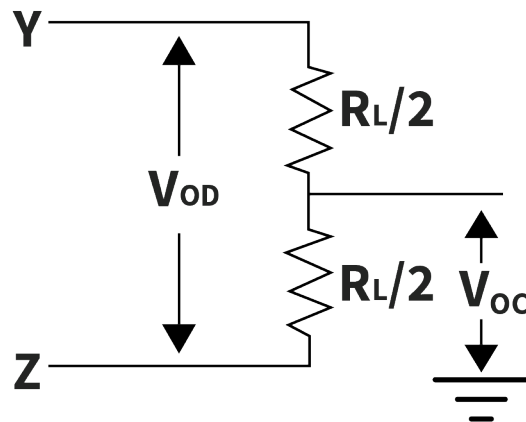

Figure 5.7 Driver DC Test Load

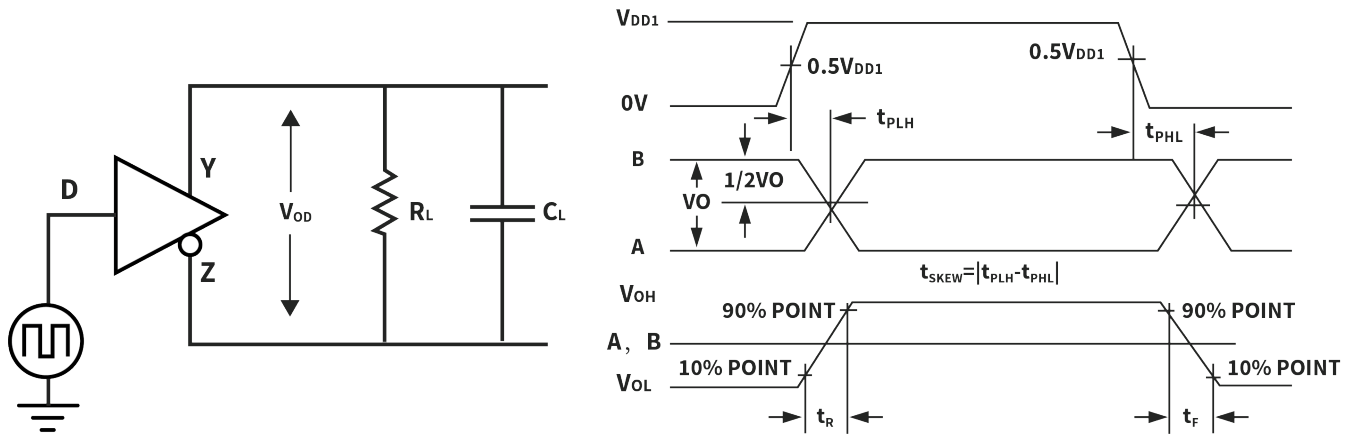

Figure 5.8 Driver Timing Test Circuit and waveform

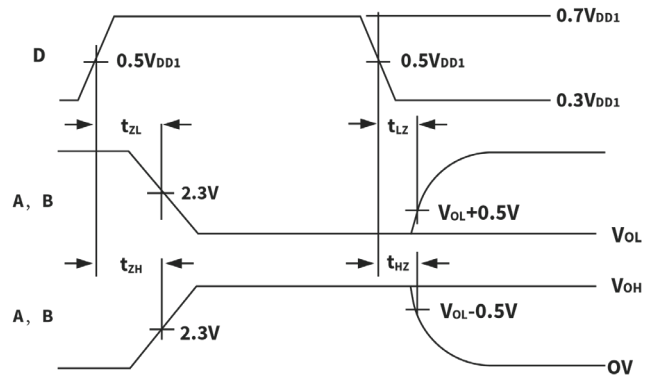
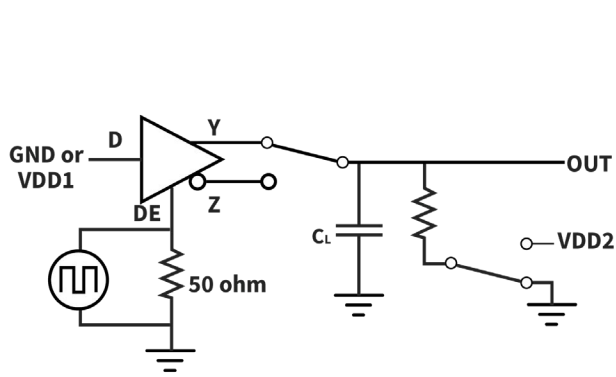

Figure 5.9 Driver Enable Disable Timing Test Circuit and waveform

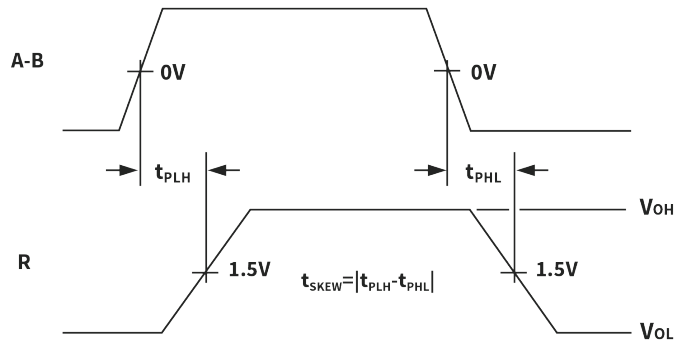
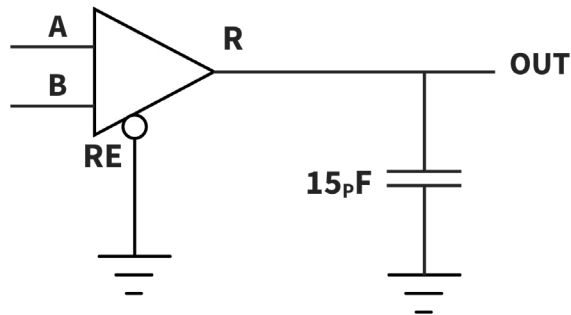

Figure 5.10 Receiver Propagation Delay Test Circuit and waveform

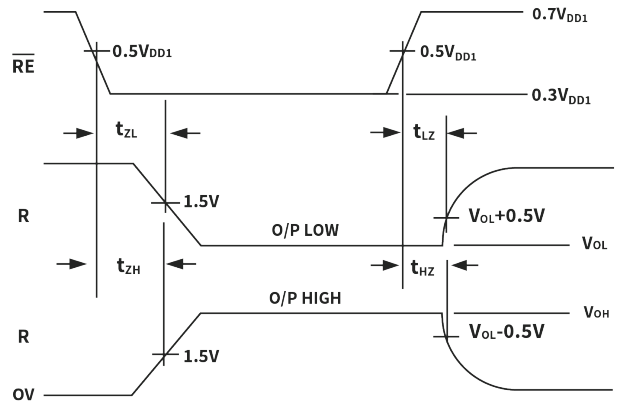
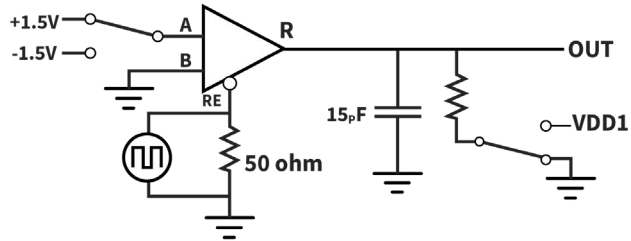

Figure 5.11 Receiver Enable Disable Timing Test Circuit and waveform

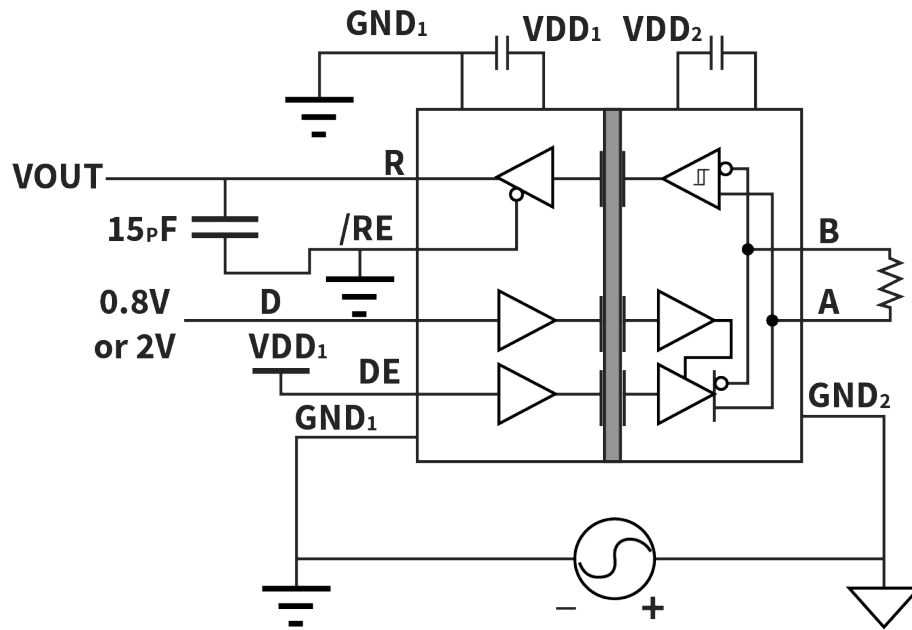

Figure 5.12 Common-Mode Transient Immunity Test Circuit

## 6. High Voltage Feature Description

### 6.1. Insulation and Safety Related Specifications

Parameters	Symbol	Value	Unit	Comments
Minimum External Clearance	CLR	8	mm	IEC 60664-1:2007
Minimum External Creepage	CPG	8	mm	IEC 60664-1:2007
Distance Through Insulation	DTI	28	µm	Distance through insulation
Tracking Resistance (Comparative Tracking Index)	CTI	>600	V	DIN EN 60112 (VDE 0303-11); IEC 60112
Material Group		I		IEC 60664-1

Description	Test Condition	Value
Overvoltage Category per IEC60664-1	For Rated Mains Voltage $\leq 150V_{rms}$	I to IV
	For Rated Mains Voltage $\leq 300V_{rms}$	I to IV
	For Rated Mains Voltage $\leq 600V_{rms}$	I to IV
	For Rated Mains Voltage $\leq 1000V_{rms}$	I to III
Climatic Classification		40/125/21
Pollution Degree per DIN VDE 0110,		2

### 6.2. Insulation Characteristics

Description	Test Condition	Symbol	Value	Unit
Maximum Working Isolation Voltage	AC voltage	$V_{IOWM}$	1500	$V_{RMS}$
	DC voltage		2121	$V_{DC}$
Maximum Repetitive Isolation Voltage		$V_{IORM}$	2121	$V_{PEAK}$
Apparent Charge	Method a, after Input/output safety test subgroup 2/3, $V_{ini}=V_{IOTM}$ , $t_{ini}=60s$ , $V_{pd(m)}=1.2*V_{IORM}$ , $t_m=10s$ .		<5	$V_{PEAK}$
	Method a, after environmental tests subgroup 1, $V_{ini}=V_{IOTM}$ , $t_{ini}=60s$ , $V_{pd(m)}=1.6*V_{IORM}$ , $t_m=10s$			$V_{PEAK}$
	Method b, routine test (100% production) and preconditioning (type test); $V_{ini}=1.2*V_{IOTM}$ , $t_{ini}=1s$			$V_{PEAK}$

	$V_{pd(m)}=1.875 \cdot V_{IORM}, t_m=1s$ (method b1) or $V_{pd(m)}=V_{ini}, t_m=t_{ini}$ (method b2)			
Maximum transient isolation voltage	$t = 60 \text{ sec}$	$V_{IOTM}$	8000	$V_{PEAK}$
Maximum Surge Isolation Voltage	Test method per IEC62368-1, 1.2/50us waveform, $V_{TEST} = 1.6 \times V_{IOSM}$	$V_{IOSM}$	10000	$V_{PEAK}$
Isolation resistance	$V_{IO} = 500V, T_A=25^\circ C$	$R_{IO}$	$>10^{12}$	$\Omega$
	$V_{IO} = 500 \text{ V}, 100^\circ C \leq T_A \leq 125^\circ C$		$>10^{11}$	$\Omega$
	$V_{IO} = 500 \text{ V}, T_A = T_s$		$>10^9$	$\Omega$
Isolation capacitance	$f = 1\text{MHz}$	$C_{IO}$	0.6	pF
Insulation Specification per UL1577				
Withstand Isolation Voltage	$V_{TEST} = V_{ISO}, t=60 \text{ s}$ (qualification), $V_{TEST} = 1.2 \times V_{ISO}, t = 1 \text{ sec},$ 100% production test	$V_{ISO}$	5000	$V_{RMS}$

- 1) This coupler is suitable for “safe electrical insulation” only within the safety ratings. Compliance with the safety ratings shall be ensured by means of suitable protective circuits.

### 6.3. Safety-Limiting Values

Description	Test Condition	Value	Unit
Safety Supply Power	$R_{\theta JA} = 67.9^\circ C/W^1), T_J = 150^\circ C, T_A = 25^\circ C$	1840	mW
Safety Supply Current	$R_{\theta JA} = 67.9^\circ C/W^1), V_I = 5V, T_J = 150^\circ C, T_A = 25^\circ C$	368	mA
Safety Temperature <sup>2)</sup>		150	$^\circ C$

- 1) Calculate with the junction-to-air thermal resistance,  $R_{\theta JA}$ , of SOP16(300mil) package ([Thermal Information Table](#)) which is that of a device installed on a low effective thermal conductivity test board (1s) according to JESD51-3.
- 2) The maximum safety temperature has the same value as the maximum junction temperature ( $T_J$ ) specified for the device.

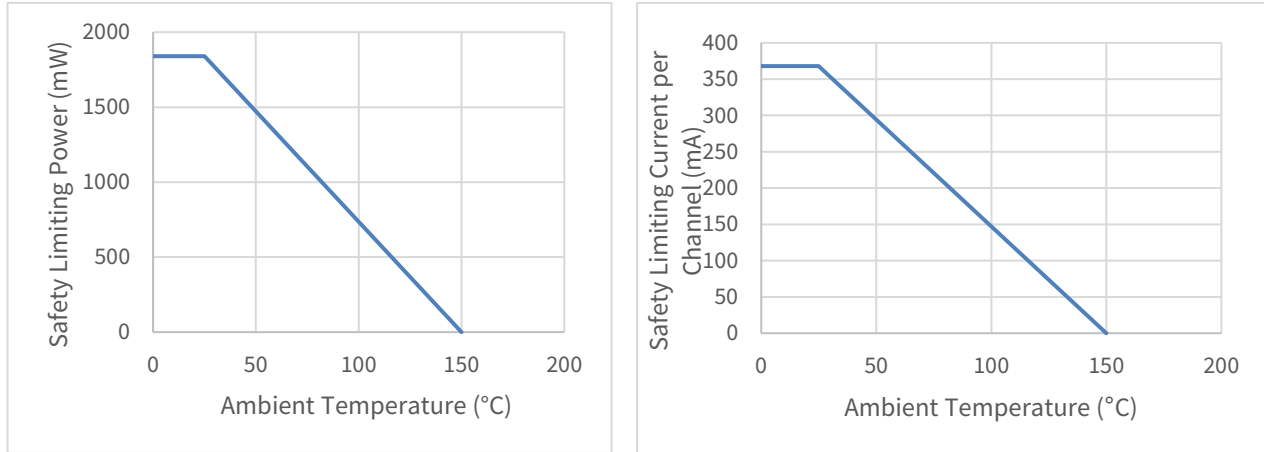

Figure 6.1 NSI83085C Thermal Derating Curve, Dependence of Safety Limiting Values with Case Temperature per DIN VDE V 0884-11

### 6.4. Regulatory information

The NSI83085C are approved or pending approval by the organizations listed in table.

<i>CUL</i>		<i>VDE</i>		<i>CQC</i>	
UL 1577 Component Recognition Program	Approved under CSA Component Acceptance Notice 5A	DIN VDE V 0884-11(VDE V 0884-11):2017-01		Certified by CQC11-471543-2012	GB4943.1-2011
Single Protection, 5000Vrms Isolation voltage	Single Protection, 5000Vrms Isolation voltage	Reinforce Insulation 2121Vpeak, VIOSM=6250Vpeak		Reinforced insulation	
File (pending)	File (pending)	File (pending)		File (pending)	

## 7. Function Description

NSI83085C is a high reliability isolated half duplex RS-485 transceiver. Data isolation is achieved using Novosense integrated capacitive isolation that allows data transmission between the logic side and the Bus side. Both devices are safety certified by UL1577 support 5kV<sub>RMS</sub> insulation withstand voltages.

### 7.1. Data rate

The data rate of NSI83085C is 12Mbps. The device is slew limited to reduce EMI and reflections with improperly terminated transmission line.

### 7.2. True Fail-safe receiver inputs

The devices feature fail-safe circuitry, which guarantees a logic-high receiver output when the receiver inputs are open or shorted. The receiver threshold is fixed between -10mV and -200mV, which meets EIA/TIA-485 standard. If the differential input voltage ( $V_A - V_B$ ) is greater than or equal to -50mV, receiver output R is logic high. In the case of a terminated bus with all transmitters disabled, the differential input voltage is pulled to zero by the termination resistors. Due to the receiver threshold, the receiver output R is logic high.

### 7.3. Truth tables

Table 7.1 Driver Function Table<sup>1</sup>

VDD1 status	VDD2 status	Input (D)	Enable Input (DE)	Outputs <sup>1</sup>	
				A	B
PU	PU	H	H	H	L
PU	PU	L	H	L	H
PU	PU	X	L	Z	Z
PU	PU	X	OPEN	Z	Z
PU	PU	OPEN	H	H	L
PD	PU	X	X	Z	Z
PU	PD	X	X	Z	Z
PD	PD	X	X	Z	Z

<sup>1</sup> PD= Powered down; PU= Powered up; H= Logic High; L= Logic Low; X= Irrelevant; Z= High Impedance

Table 7.2 Receiver Function Table<sup>1</sup>

VDD1 status	VDD2 status	Differential Input ( $V_A - V_B$ )	Enable Input (/RE)	Output (R)
PU	PU	$\geq -10\text{mV}$	L/Open	H
PU	PU	$\leq -200\text{mV}$	L/Open	L
PU	PU	Open/Short	L/Open	H
PU	PU	X	H	Z
PU	PU	Idle	L	H
PD	PU	X	X	Z

<i>VDD1 status</i>	<i>VDD2 status</i>	<i>Differential Input</i> <i>(V<sub>A</sub>-V<sub>B</sub>)</i>	<i>Enable Input</i> <i>(/RE)</i>	<i>Output</i> <i>(R)</i>
PU	PD	X	L/Open	H
PD	PD	X	X	Z

<sup>1</sup> PD= Powered down; PU= Powered up; H= Logic High; L= Logic Low; X= Irrelevant; Z= High Impedance.

## 7.4. Thermal shutdown

The device is protected from over temperature damage by integrated thermal shutdown circuitry. When the junction temperature (T<sub>J</sub>) exceeds +165°C (typ), the driver outputs go high-impedance. The device resumes normal operation when T<sub>J</sub> falls below +145°C (typ).

## 8. Application Note

### 8.1. 256 transceivers on the bus

The devices have a 1/8-unit-load receiver input impedance (96kΩ) that allows up to 256 transceivers on the bus. Connect any combination of these devices, and/or other RS-485 devices, for a maximum of 32 unit-loads to the line.

### 8.2. ESD protection

ESD protection structures are enhanced on all pins to protect against electrostatic discharge encountered during handling and assembly. The Bus pins have extra protection against static electricity to both the logic side (VDD1 side) and bus side (VDD2 side).

ESD protection can be tested in various ways. Below is the ESD spec of the devices.

Bus pins:

- ± 8kV HBM.
- ±10kV using the Contact Discharge method specified in IEC 61000-4-2

Other pins except bus pins:

- ±6kV HBM.
- ±7kV using the Contact Discharge method specified in IEC 61000-4-2

### 8.3. Layout considerations

The NSI83085C requires a 0.1 μF bypass capacitor between VDD and GND. The capacitor should be placed as close as possible to the package. To eliminate line reflections, each cable end is terminated with a resistor, whose value matches the characteristic impedance of the cable. It's good practice to have the bus connectors and termination resistor as close as possible to the A and B pins.

8.4. Typical application

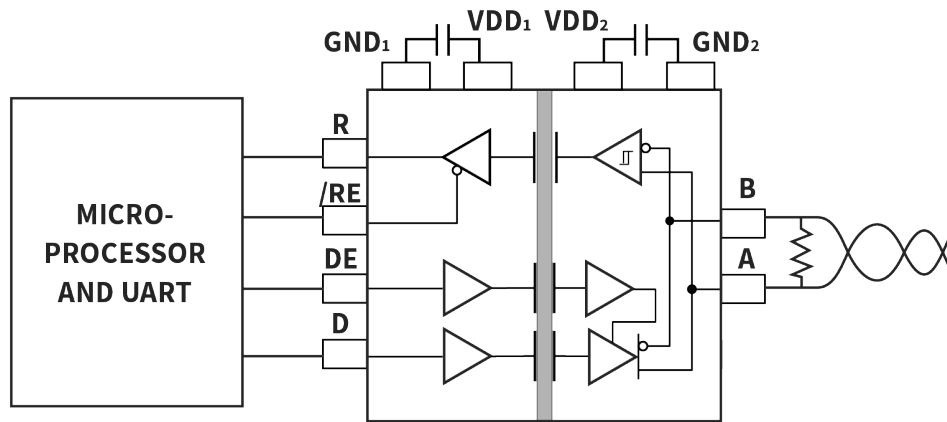

Figure 8.1 NSI83085C typical application circuit

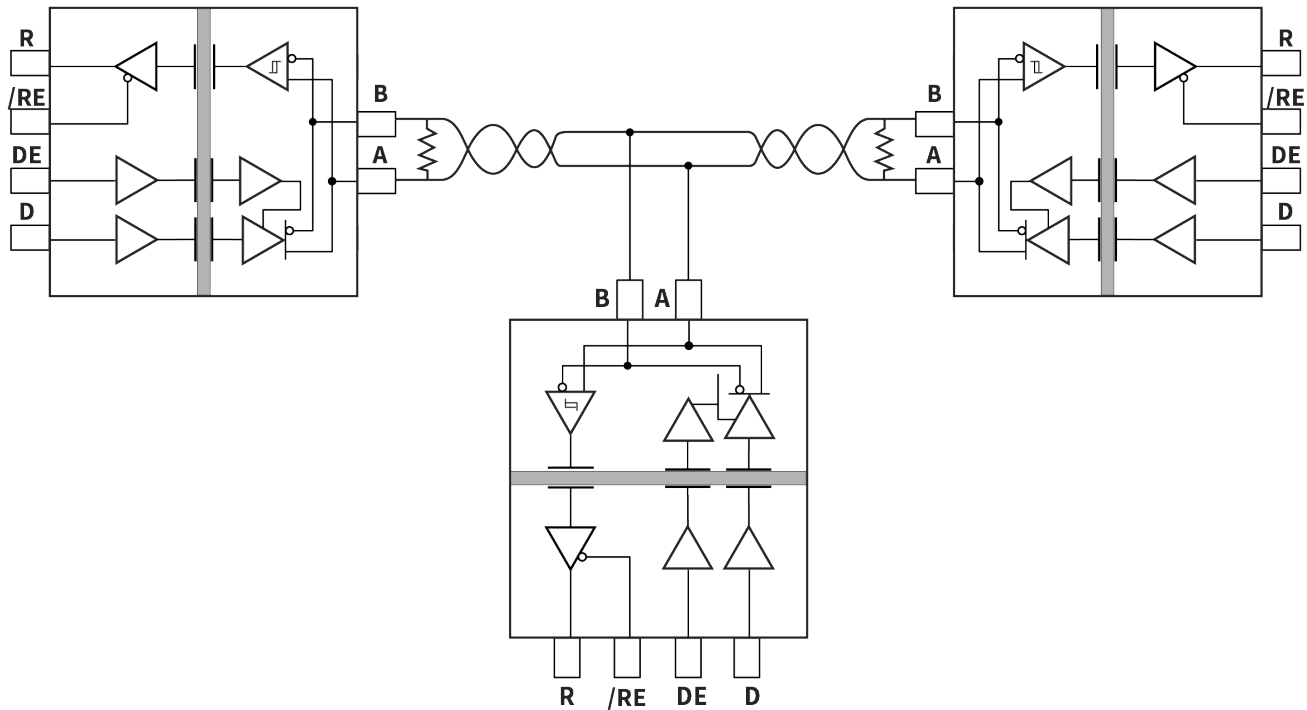

Figure 8.2 Typical isolated Half-Duplex RS-485 application

### 9. Package Information

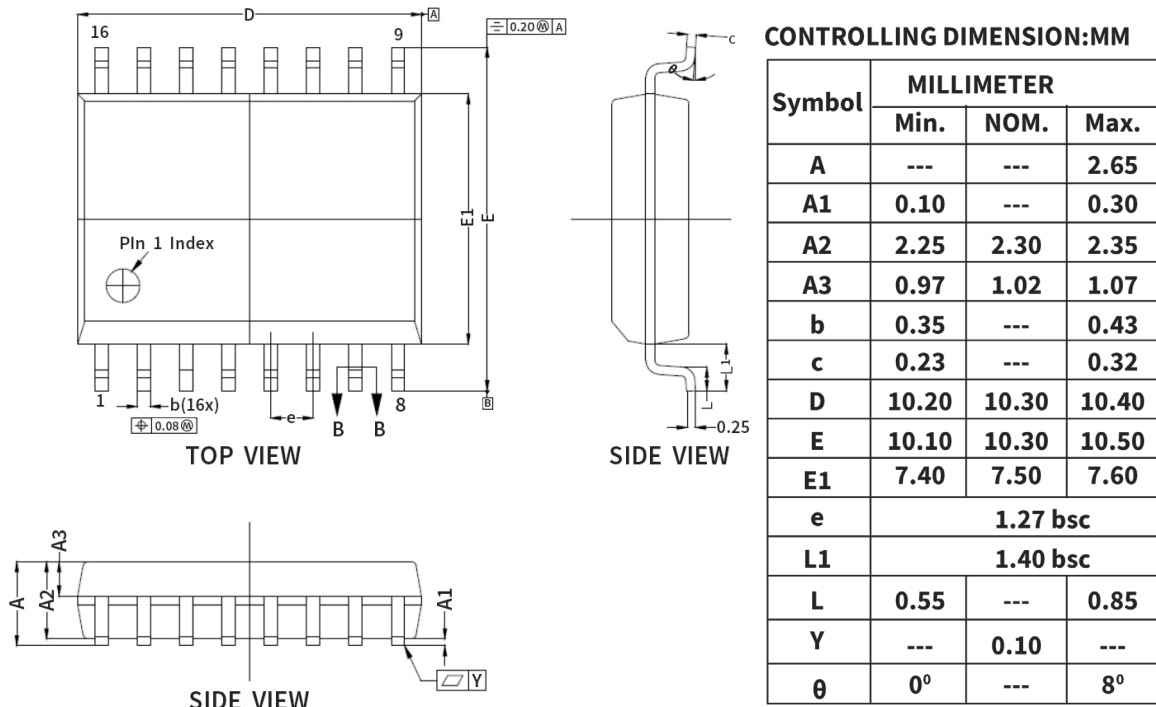

Figure 9.1 SOW16 Package Shape and Dimension in millimeters

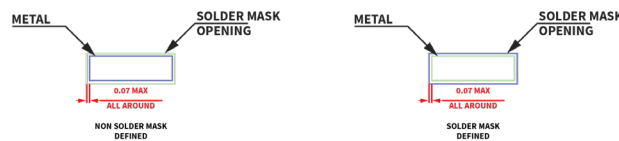
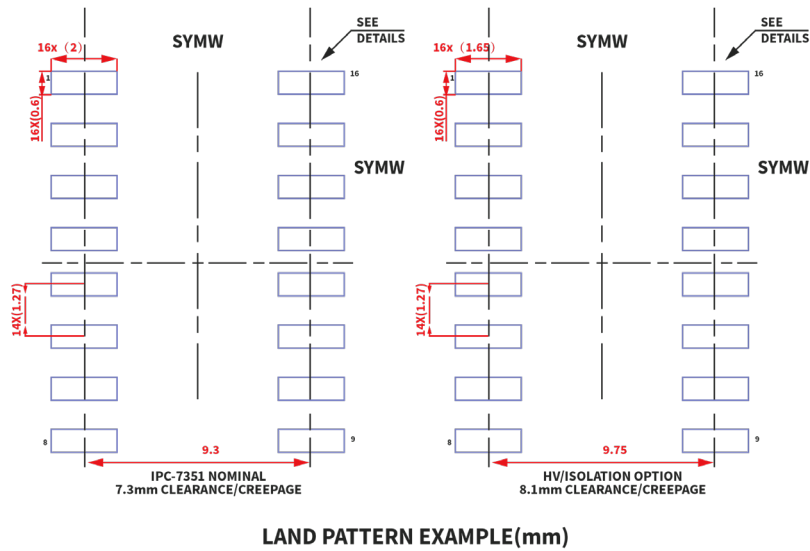
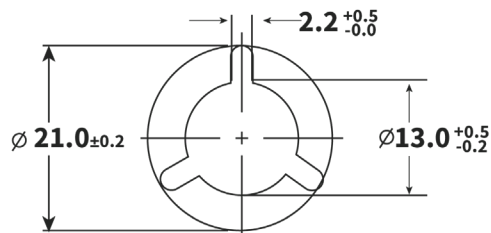
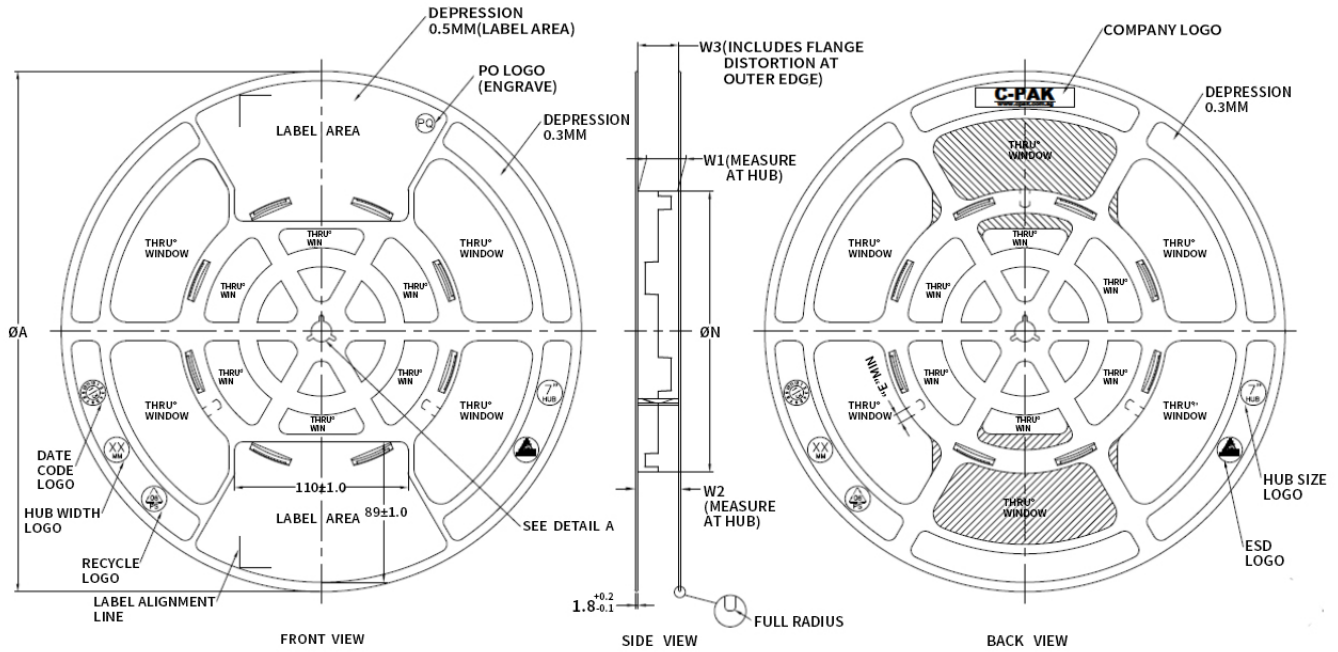

Figure 9.2 SOW16 Package Board Layout Example

## 10. Order Information

<i>Part Number</i>	<i>Isolation Rating (kV)</i>	<i>Duplex</i>	<i>Max Data Rate (Mbps)</i>	<i>No. of Nodes</i>	<i>Temperature</i>	<i>MSL</i>	<i>Package Type</i>	<i>Package Drawing</i>	<i>SPQ</i>
NSI83085C-DSWR	5	Half	12	256	-40 to 105°C	2	SOP16 (300mil)	SOW16	1000
NOTE: All packages are RoHS-compliant with peak reflow temperatures of 260 °C according to the JEDEC industry standard classifications and peak solder temperatures.									

### 11. Tape and Reel Information



PRODUCT SPECIFICATION						
TAPE WIDTH	$\varnothing A \pm 2.0$	$\varnothing N \pm 2.0$	W1	W2 (Max)	W3	E (Min)
08MM	330	178	$8.4^{+1.5}_{-0.0}$	14.4	SHALL ACCOMMODATE TAPE WIDTH WITHOUT INTERFERENCE	5.5
12MM	330	178	$12.4^{+2.0}_{-0.0}$	18.4		5.5
16MM	330	178	$16.4^{+2.0}_{-0.0}$	22.4		5.5
24MM	330	178	$24.4^{+2.0}_{-0.0}$	30.4		5.5
32MM	330	178	$32.4^{+2.0}_{-0.0}$	38.4		5.5

SURFACE RESISTIVITY			
LEGEND	SR RANGE	TYPE	COLOUR
A	BELOW $10^{12}$	ANTISTATIC	ALL TYPES
B	$10^6$ TO $10^{11}$	STATIC DISSIPATIVE	BLACK ONLY
C	$10^5$ & BELOW $10^5$	CONDUCTIVE (GENERIC)	BLACK ONLY
E	$10^9$ TO $10^{11}$	ANTISTATIC (COATED)	ALL TYPES

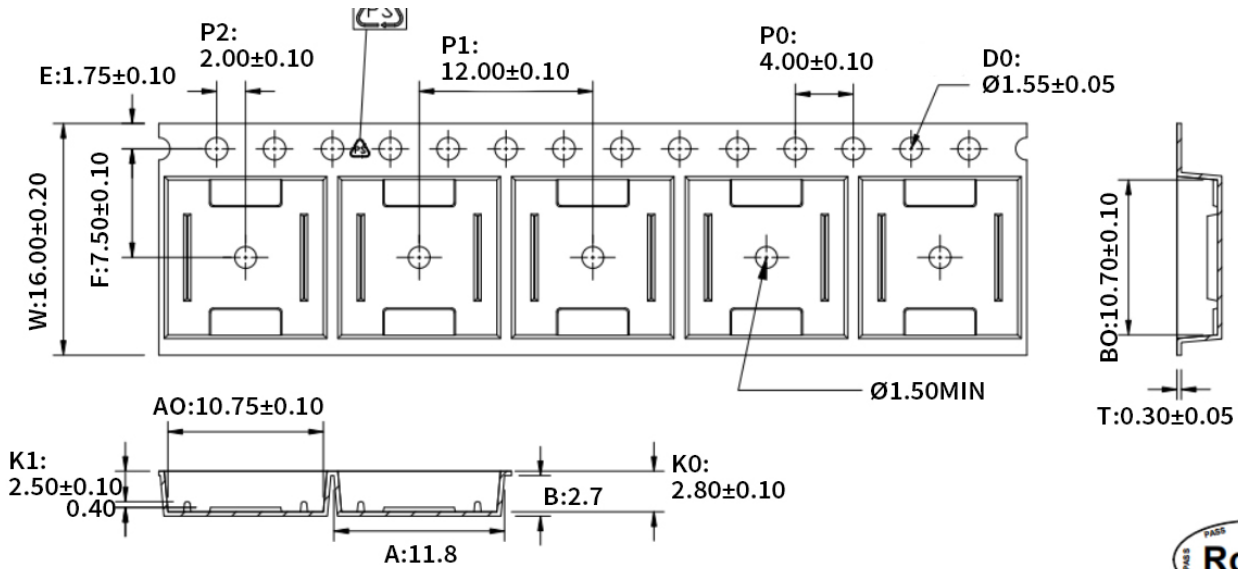

1. 1.10 sprocket hole pitch cumulative tolerance  $\pm 0.20$ .
2. Carrier camber is within 1 mm in 250 mm.
3. Material : Black Conductive Polystyrene Alloy.
4. All dimensions meet EIA-481 requirements.
5. Thickness:  $0.30 \pm 0.05$ mm.
6. Packing length per 22" reel: 378 Meters.(復卷 N=122 )
7. Component load per 13" reel: 1000 pcs.
8. Surface resistivity:  $10^5 \sim 10^{10} \Omega/\square$



W	16.00±0.20
A0	10.75±0.10
B0	10.70±0.10
K0	2.80±0.10
K1	2.50±0.10

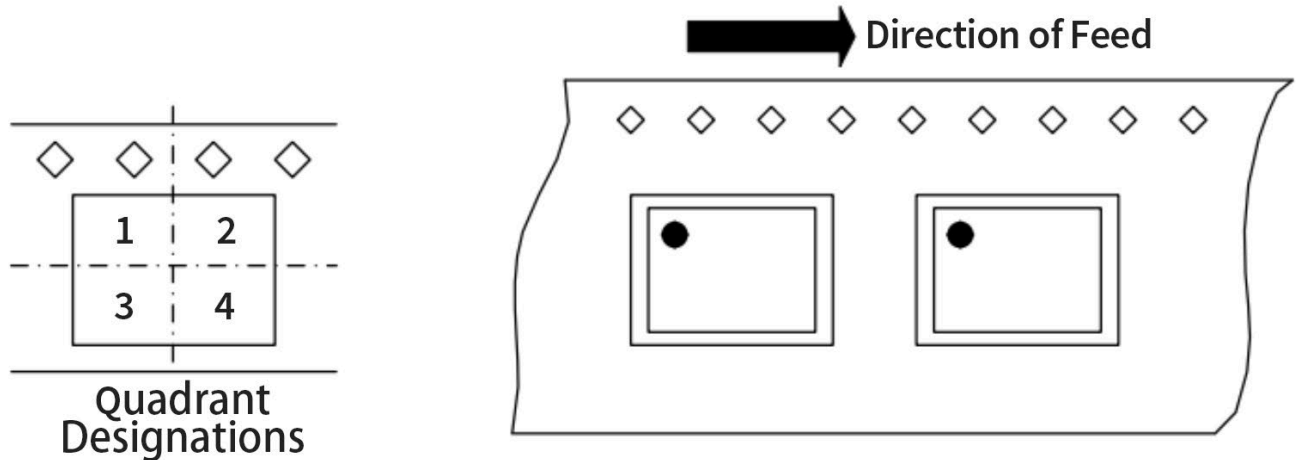

Figure 11.1 Tape and Reel Information of SOW16

## 12. Revision History

<i>Revision</i>	<i>Description</i>	<i>Date</i>
1.0	Initial version	2022/11/3
1.1	Update CMTI, Data rate.	2023/3/10
1.2	Update Data rate. Remove NSI83086C	2023/9/19

## **IMPORTANT NOTICE**

The information given in this document shall in no event be regarded as any warranty or authorization of, express or implied, including but not limited to accuracy, completeness, merchantability, fitness for a particular purpose or infringement of any third party's intellectual property rights.

You are solely responsible for your use of Novosense' products and applications, and for the safety thereof. You shall comply with all laws, regulations and requirements related to Novosense's products and applications, although information or support related to any application may still be provided by Novosense.

The resources are intended only for skilled developers designing with Novosense' products. Novosense reserves the rights to make corrections, modifications, enhancements, improvements or other changes to the products and services provided. Novosense authorizes you to use these resources exclusively for the development of relevant applications designed to integrate Novosense's products. Using these resources for any other purpose, or any unauthorized reproduction or display of these resources is strictly prohibited. Novosense shall not be liable for any claims, damages, costs, losses or liabilities arising out of the use of these resources.

For further information on applications, products and technologies, please contact Novosense ([www.novosns.com](http://www.novosns.com) ).

**Suzhou Novosense Microelectronics Co., Ltd**