

Product Overview

The NSI3611D is a high-performance isolated amplifier with integrated isolated power supply. The device accepts a single-ended input signal range from 0V to 2V. The integrated isolated power supply enables single-power operation on the low side of the device without the need for a separate isolated power supply for the high side, effectively reducing the board area. The high input impedance of NSI3611D makes it highly suitable for connection to high-voltage resistive dividers or other voltage signal sources with high output resistance.

The device has a fixed gain of 1 and provides a differential analog output. The low offset and gain drift ensure the accuracy over the entire temperature range. High common-mode transient immunity ensures that the device is able to provide accurate and reliable measurements even in the presence of high-power switching such as in motor control applications.

The integrated isolated power supply detection and the open-drain diagnosis output simplify system-level design and diagnostics.

Key Features

- Up to 5000V_{rms} Insulation voltage
- 0V~2V linear Input Voltage Range
- Low Offset Error and Drift:
±1.2mV (Max), ±20µV/°C (Max)
- Low Gain Error and Drift:
±0.25% (Max), ±45ppm/°C (Max)
- Low Nonlinearity and Drift:
±0.04% (Max), ±1ppm/°C (Typ)
- SNR: 78dB (Typ, BW=10kHz), 66dB (Typ, BW=100kHz)
- Wide bandwidth: 340kHz (Typ)
- High CMTI: 150kV/µs (Typ)

- System-Level Diagnostic Features: integrated isolated power supply detection
- Operation Temperature: -40°C ~125°C
- AEC-Q100 qualified for automotive applications: Grade 1
- RoHS-Compliant Packages: SOP16(300mil)

Safety Regulatory Approvals

- UL recognition: 5000V_{rms} for 1 minute per UL1577
- CQC certification per GB4943.1
- CSA component notice 5A
- DIN EN IEC 60747-17 (VDE 0884-17)

Applications

- DC Voltage Sensing
- Traction Inverters
- Battery Management Units
- On Board Chargers
- DC/DC Converters

Device Information

Part Number	Package	Body Size
NSI3611D-Q1SWR	SOP16(300mil)	10.30mm × 7.50mm

Functional Block Diagrams

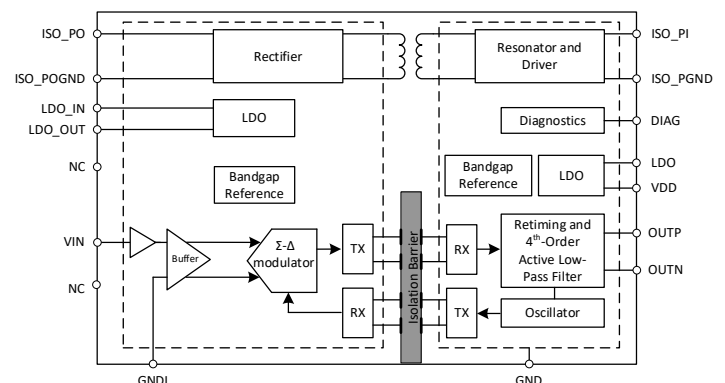

Figure 1. Function Block Diagram of NSI3611D

INDEX

1. PIN CONFIGURATION AND FUNCTIONS	3
2. ABSOLUTE MAXIMUM RATINGS ⁽¹⁾	4
3. ESD RATINGS ⁽¹⁾	4
4. RECOMMENDED OPERATING CONDITIONS	4
5. THERMAL INFORMATION	4
6. SPECIFICATIONS	5
6.1. ELECTRICAL CHARACTERISTICS	5
6.2. TIMING DIAGRAMS	7
6.3. TYPICAL PERFORMANCE CHARACTERISTICS	7
7. HIGH VOLTAGE FEATURE DESCRIPTION	11
7.1. INSULATION AND SAFETY RELATED SPECIFICATIONS	11
7.2. INSULATION CHARACTERISTICS	11
7.3. REGULATORY INFORMATION	12
8. FUNCTION DESCRIPTION	13
8.1. OVERVIEW	13
8.2. ANALOG INPUT AND OUTPUT	14
8.3. ACCURACY RELATED PARAMETERS	14
8.3.1. Input offset V_{OS} and Gain Error E_G	14
8.3.2. Input offset drift TCV_{OS} and Gain error thermal drift TCE_G	15
8.3.3. Nonlinearity.....	15
8.3.4. Power-Supply Rejection Ratio	15
8.3.5. Common-Mode Rejection Ratio.....	15
8.3.6. Total Error Calculation	15
8.4. ISOLATED POWER	17
8.5. DIAGNOSTIC OUTPUT	17
9. APPLICATION NOTE	18
9.1. TYPICAL APPLICATION CIRCUIT	18
9.2. HIGH VOLTAGE DIVIDING RESISTOR SELECTION	19
9.3. HOW TO DESIGN INPUT CONDITIONING CIRCUIT	19
9.4. PCB LAYOUT	19
10. PACKAGE INFORMATION	20
11. ORDERING INFORMATION	21
12. DOCUMENTATION SUPPORT	21
13. TAPE AND REEL INFORMATION	22
14. REVISION HISTORY	23

1. Pin Configuration and Functions

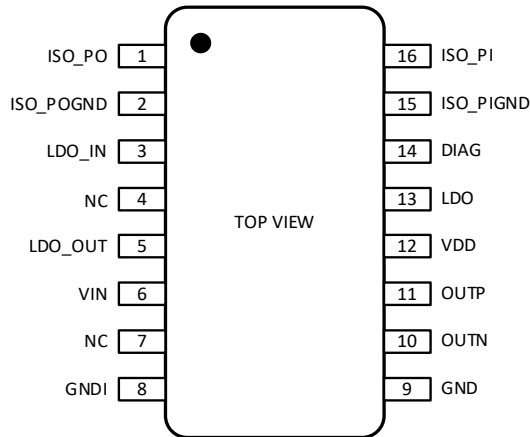

Figure 1.1 NSI3611D Package

Table 1.1 NSI3611D Pin Configuration and Description

NSI3611D PIN NO.	SYMBOL	FUNCTION
1	ISO_PO	Internal isolated power output (need to be connected to the LDO_IN pin)
2	ISO_POGND	Internal isolated power ground reference (need to be connected to the GNDI pin)
3	LDO_IN	Internal input side LDO power input (need to be connected to the ISO_PO pin)
4	NC	Not internal connected, leave this pin floating or connect to GNDI
5	LDO_OUT	Internal input side LDO power output
6	VIN	Single-ended analog input
7	NC	Not internal connected, leave this pin floating or connect to GNDI
8	GNDI	Input side ground reference (need to be connected to the ISO_POGND pin)
9	GND	Output side ground reference (need to be connected to the ISO_PIGND pin)
10	OUTN	Negative analog output
11	OUTP	Positive analog output
12	VDD	Output side power supply
13	LDO	Internal output side LDO power input (need to be connected to the ISO_PI pin and without external load)
14	DIAG	Open-drain diagnosis output (need to be connected to the pull-up supply or floating)
15	ISO_PIGND	Internal isolated power ground reference (need to be connected to the GND pin)
16	ISO_PI	Internal isolated power input (need to be connected to the LDO pin)

2. Absolute Maximum Ratings ⁽¹⁾

Parameters	Symbol	Min	Typ	Max	Unit
Power Supply Voltage	VDD to GND	-0.3		6.5	V
Analog Input Voltage	V _{IN}	GNDI-6		LDO_OUT+0.5	V
Analog Output Voltage	OUTP, OUTN	GND-0.5		VDD+0.5	V
Digital Output Voltage	DIAG	GND-0.5		6.5	V
Input current per output Pin	I _{IN}	-10		10	mA
Junction Temperature	T _J	-40		150	°C
Storage Temperature	T _{STG}	-55		150	°C

(1) The device cannot operate beyond the listed Absolute Maximum Ratings to prevent permanent device damage. The device is not fully functional if operating outside the Recommended Operating Conditions but within the Absolute Maximum Ratings. Long-time stress of the absolute maximum conditions may affect the device lifetime.

3. ESD Ratings ⁽¹⁾

Parameters	Test Condition	Value	Unit
Electrostatic discharge	Human body model (HBM), per AEC-Q100-002-RevD	±4.0	kV
	Charged device model (CDM), per AEC-Q100-011-RevB	±1.0	kV

(1) Though this device features proprietary protection circuitry, proper ESD precautions should be considered to avoid performance degradation or damage due to high energy ESD event. Charged devices and circuit boards may discharge without detection.

4. Recommended Operating Conditions

Parameters	Symbol	Min	Typ	Max	Unit
Power Supply	VDD to IGND	3.0	3.3	5.5	V
Input voltage before clipping output	V _{Clipping}		2.5		V
Linear differential input full scale voltage	V _{FSR}	0		2	V
DIAG pull-up supply voltage	V _{DIAG}	0		VDD	V
Operating Ambient Temperature	T _A	-40		125	°C

5. Thermal Information

Parameters	Symbol	SOP16(300mil)	Unit
Junction-to-ambient thermal resistance	R _{θJA}	64	°C/W
Junction-to-case (top) thermal resistance	R _{θJC(top)}	30	°C/W
Junction-to-board thermal resistance	R _{θJB}	33.3	°C/W
Junction-to-top characterization parameter	Ψ _{JT}	10.9	°C/W
Junction-to-board characterization parameter	Ψ _{JB}	28.2	°C/W

6. Specifications

6.1. Electrical Characteristics

(VDD = 3.0V ~ 5.5V, VIN = 0V to 2V, TA = -40°C to 125°C. Unless otherwise noted, Typical values are at VDD = 3.3V, TA = 25°C)

Parameters	Symbol	Min	Typ	Max	Unit	Comments
Power Supply						
Output side supply voltage	VDD	3.0	3.3	5.5	V	
Output side supply current	IDD		31.3	42	mA	no external load on LDO_OUT
Output side supply current	IDD		32.6	43.2	mA	1mA external load on LDO_OUT
External load current on Input side LDO	IE			1	mA	
Isolated power output voltage	VISO_PO	3	3.5	4.6	V	ISO_PO to GNDI
Input side LDO output voltage	VLDO_OUT	3	3.2	3.3	V	LDO_OUT to GNDI
Isolated power output undervoltage detection threshold voltage	VISO_POUV	2.1	2.3	2.8	V	
Input side LDO undervoltage detection threshold voltage	VLDO_UV	2.1	2.3	2.8	V	
VDD undervoltage detection threshold voltage	VDDUV			2.95	V	
Analog Input						
Input offset voltage	VOS	-1.2	±0.1	1.2	mV	VIN = 0V, at TA = 25°C
Input offset drift ⁽¹⁾	TCVOS	-20	1	20	µV/°C	
Single-ended input resistance	RIN		1		GΩ	
Input capacitance	CI		4.5		pF	Single-ended input capacitance, fin=310kHz
Input bias current	IIB		1		nA	VIN=0V, at TA = 25°C
Input bias current drift ⁽¹⁾	TClB		-14		pA/°C	
Analog Output						
Nominal Gain			1		V/V	
Gain error	EG	-0.25%	±0.05%	0.25%		at TA = 25°C
Gain error thermal drift ⁽¹⁾	TCEG	-45	±15	45	ppm/°C	
Nonlinearity		-0.04%	±0.01%	0.04%		
Nonlinearity drift ⁽¹⁾			1		ppm/°C	
Total harmonic distortion ⁽³⁾	THD		-85		dB	VIN = 2Vpp, fin = 10kHz, BW = 100kHz

Parameters	Symbol	Min	Typ	Max	Unit	Comments
Output noise			300		μV_{RMS}	$V_{\text{IN}} = 0\text{V}$, $\text{BW} = 100\text{kHz}$
Signal to noise ratio	SNR	72	78		dB	$V_{\text{IN}} = 2\text{V}_{\text{pp}}$, $f_{\text{IN}} = 1\text{kHz}$, $\text{BW} = 10\text{kHz}$
	SNR		66		dB	$V_{\text{IN}} = 2\text{V}_{\text{pp}}$, $f_{\text{IN}} = 10\text{kHz}$, $\text{BW} = 100\text{kHz}$, 1MHz filter
Common-mode output voltage	V_{CMout}	1.35	1.42	1.48	V	
Differential clipping output voltage	V_{CLout}		2.4		V	$V_{\text{OUT}} = (V_{\text{OUTP}} - V_{\text{OUTN}})$, $V_{\text{IN}} > V_{\text{Clipping}}$
Failsafe differential output voltage	V_{FAILSAFE}		-2.55	-2.5	V	
Output bandwidth	BW		340		kHz	
Power supply rejection ratio ⁽²⁾	PSRR_{dc}		-92		dB	PSRR vs VDD, from 3.0~5.5V at DC
	PSRR_{ac}		-84		dB	PSRR vs VDD, 100mV and 10kHz ripple
Output resistance	R_{OUT}		0.3		Ω	
Output capacitance	C_{LOAD}		500		pF	
Output limit current	I_{lim}		± 20		mA	
Common-mode transient immunity	CMTI	100	150		kV/ μs	Common-mode transient immunity
Timing						
Rising time of OUTP, OUTN	t_{r}		1.1		μs	
Falling time of OUTP, OUTN	t_{f}		1.1		μs	
VIN to OUTP, OUTN signal delay (50% - 50%)	t_{PD}		1.4	1.8	μs	
Analog setting time	t_{AS}		0.9		ms	VDD step to 3.0 V, to OUTP, OUTN valid, 0.1% settling

(1) The temperature drift is calculated within the whole temperature range (-40°C to 125°C).

(2) Input referred.

(3) THD is defined as the ratio of the sum of the rms value of first five higher harmonics to the amplitude of the fundamental (input referred).

6.2. Timing Diagrams

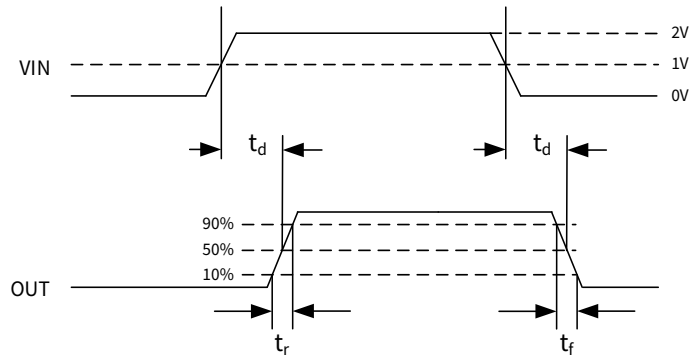

Figure 6.1 Propagation Delay and Output Fall Time Definition

6.3. Typical Performance Characteristics

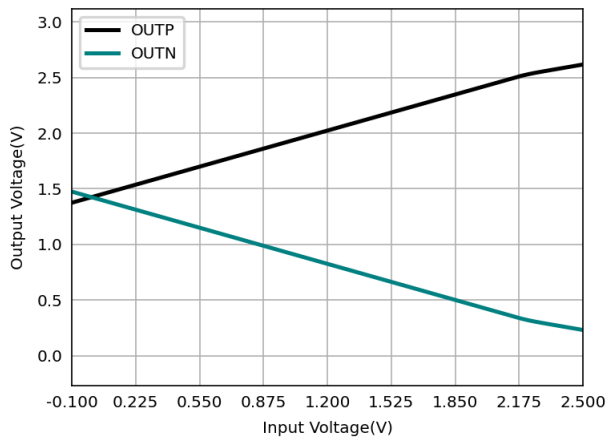

Figure 6.2 Output vs Input Voltage

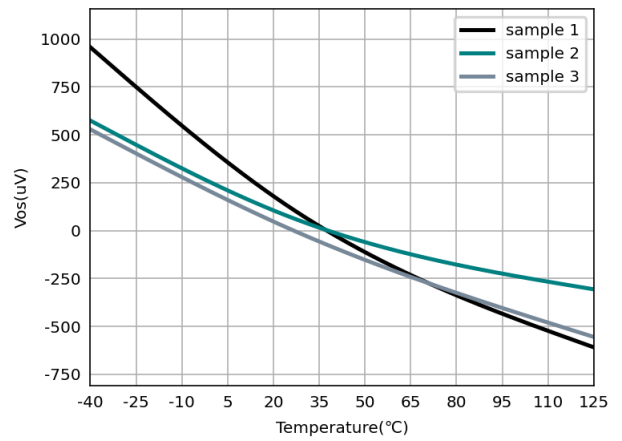

Figure 6.3 Input Offset Voltage vs Temperature

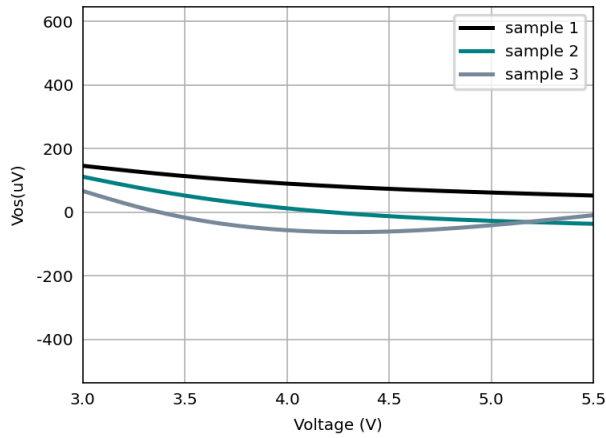

Figure 6.4 Input Offset Voltage vs Supply Voltage

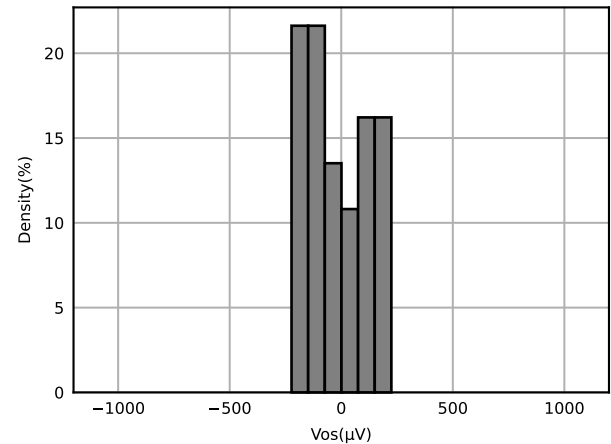

Figure 6.5 Input Offset Voltage Distribution ⁽¹⁾

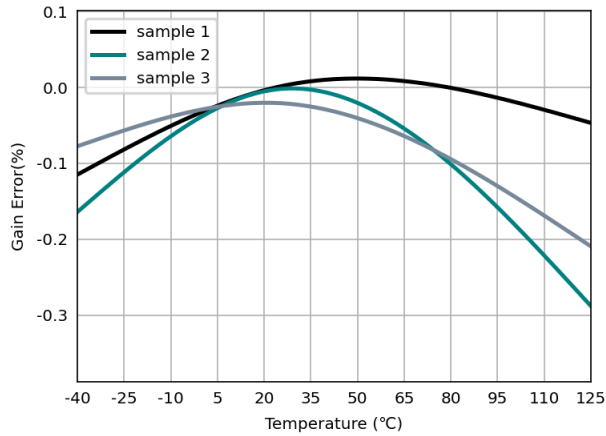

Figure 6.6 Gain Error vs Temperature

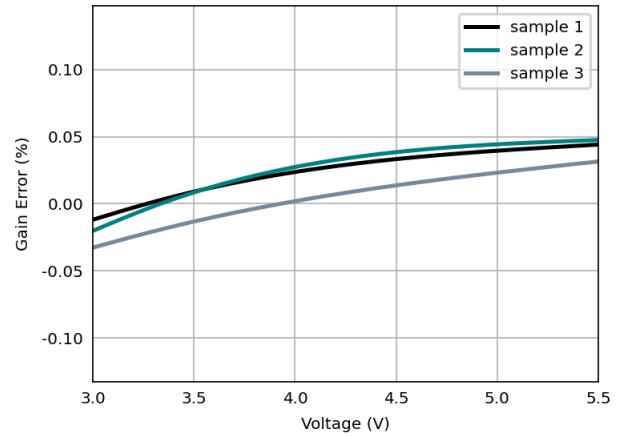

Figure 6.7 Gain Error vs Supply Voltage

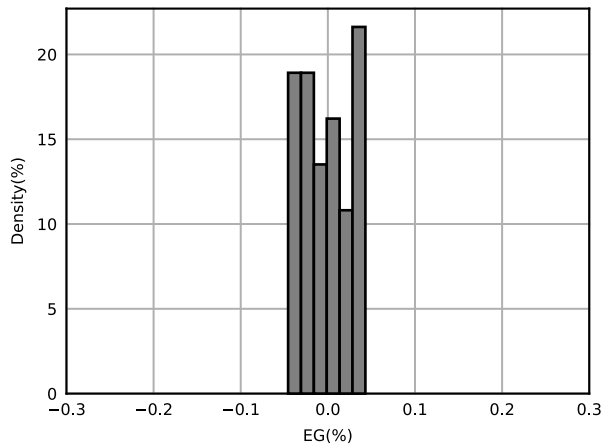

Figure 6.8 Gain Error Distribution ⁽¹⁾

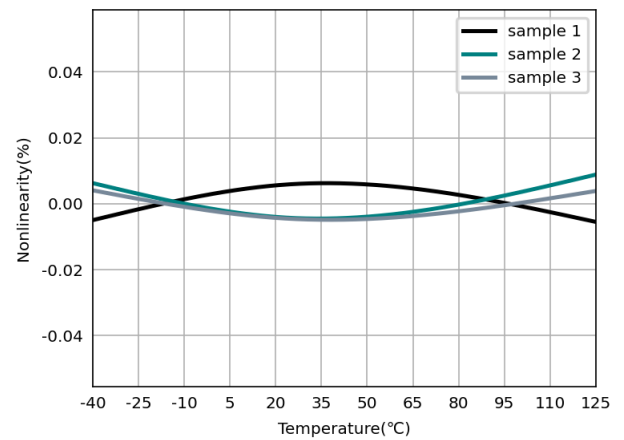

Figure 6.9 Nonlinearity vs Temperature

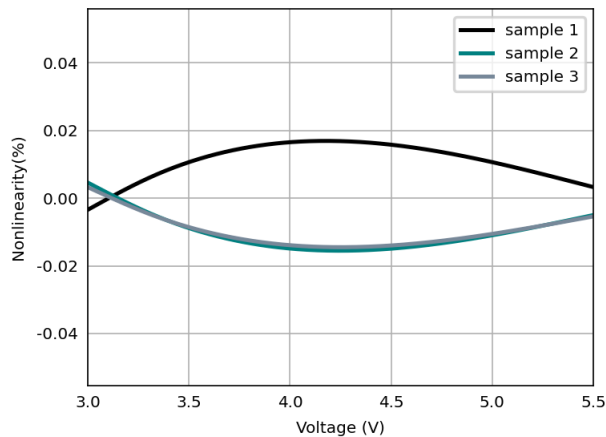

Figure 6.10 Nonlinearity vs Supply Voltage

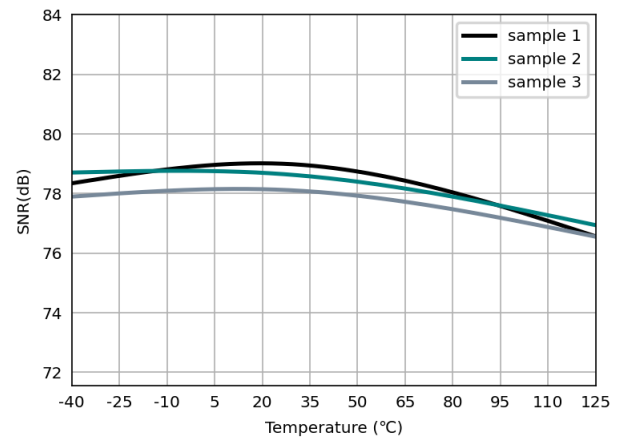

Figure 6.11 Signal to Noise Ratio vs Temperature

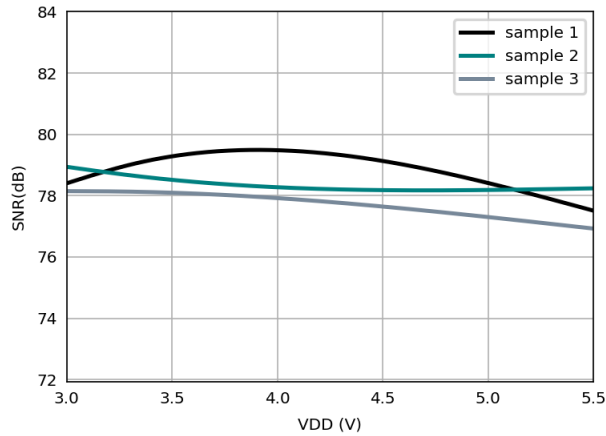

Figure 6.12 Signal to Noise Ratio vs Supply Voltage

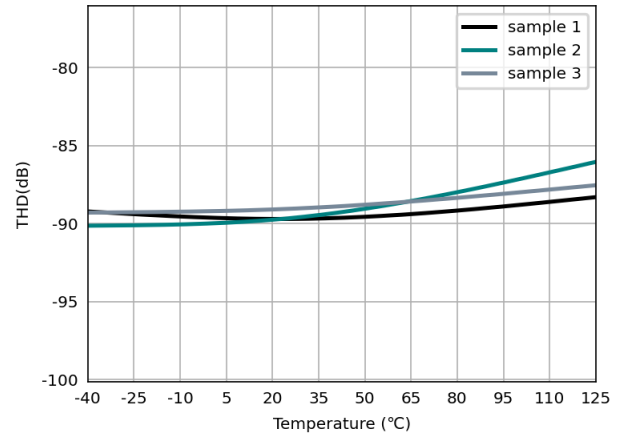

Figure 6.13 Total Harmonic Distortion vs Temperature

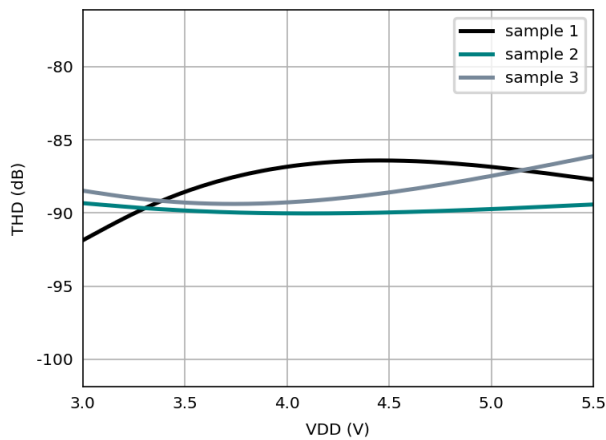

Figure 6.14 Total Harmonic Distortion vs Supply Voltage

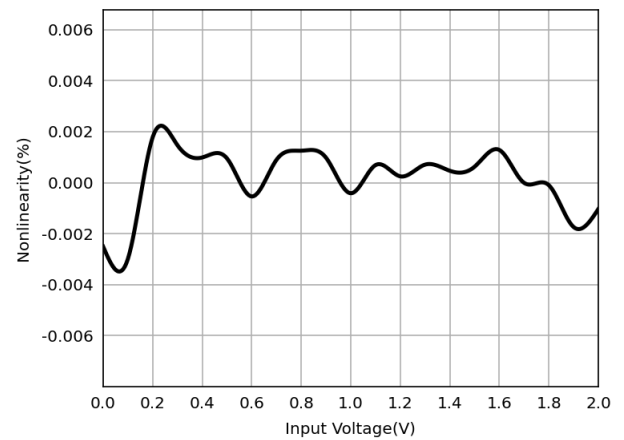

Figure 6.15 Nonlinearity vs Input Voltage

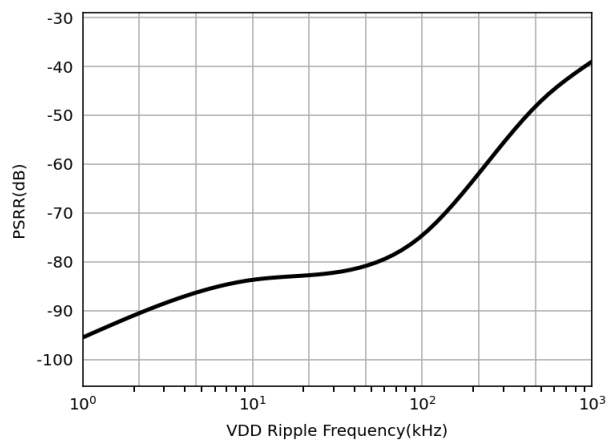

Figure 6.16 Power-Supply Rejection Ratio vs VDD Input Frequency

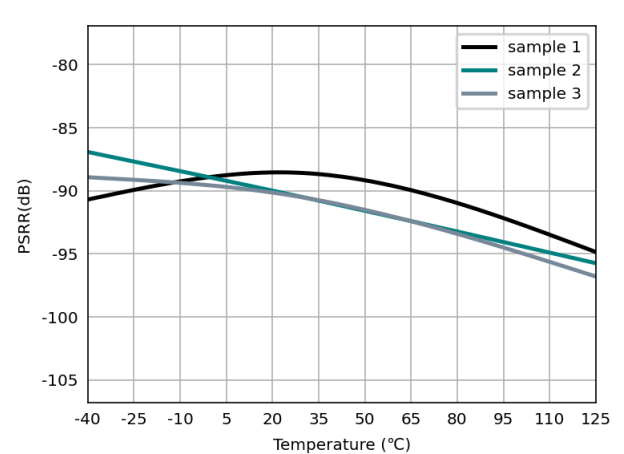

Figure 6.17 Power-Supply Rejection Ratio vs Temperature

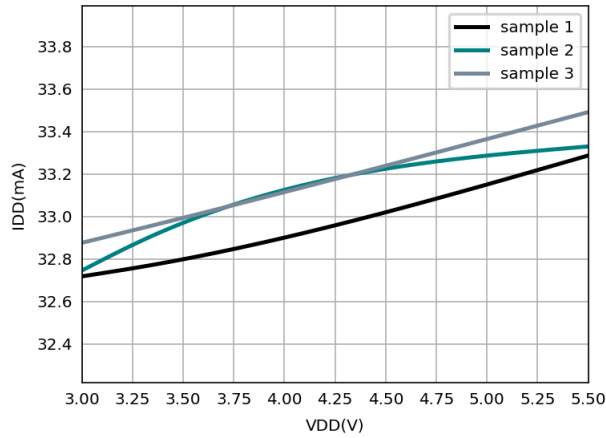

Figure 6.18 Input Supply Current vs Supply Voltage (IE=1mA)

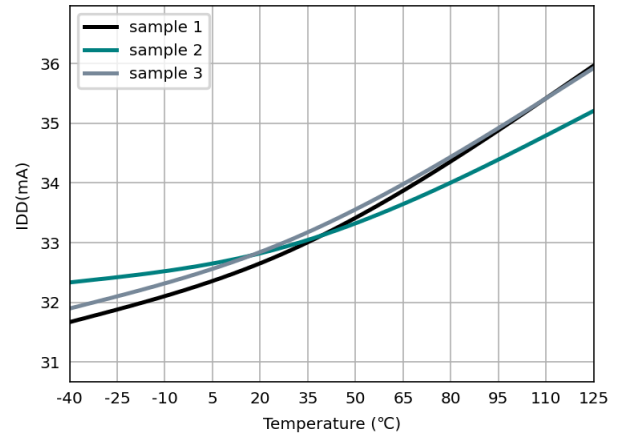

Figure 6.19 Input Supply Current vs Temperature (IE=1mA)

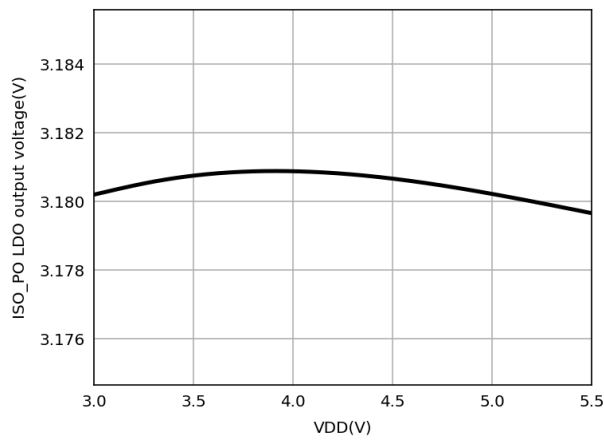

Figure 6.20 ISO-PO LDO Regulation

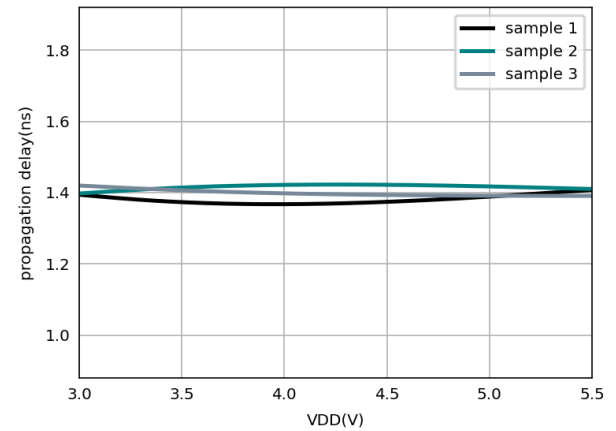

Figure 6.21 Input and Output Signal Delay time vs Supply Voltage

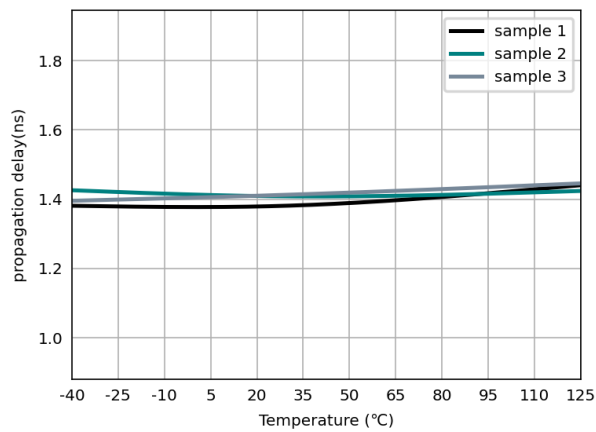

Figure 6.22 Input and Output Signal Delay time vs Temperature

(1) According to the test results of 30 pcs samples.

7. High Voltage Feature Description

7.1. Insulation and Safety Related Specifications

Parameters	Symbol	Value	Unit	Comments
Minimum External Clearance	CLR	8	mm	IEC 60664-1:2007
Minimum External Creepage	CPG	8	mm	IEC 60664-1:2007
Distance Through Insulation	DTI	26	μm	Distance through insulation (internal clearance – capacitive signal isolation)
		75	μm	Distance through insulation (internal clearance – transformer power isolation)
Tracking Resistance (Comparative Tracking Index)	CTI	>600	V	DIN EN 60112 (VDE 0303-11); IEC 60112
Material Group		I		IEC 60664-1

Description	Test Condition	Value
Overvoltage Category per IEC60664-1	For Rated Mains Voltage ≤ 150Vrms	I to IV
	For Rated Mains Voltage ≤ 300Vrms	I to IV
	For Rated Mains Voltage ≤ 600Vrms	I to IV
	For Rated Mains Voltage ≤ 1000Vrms	I to III
Climatic Classification		40/125/21
Pollution Degree per DIN VDE 0110		2

7.2. Insulation Characteristics

Description	Test Condition	Symbol	Value	Unit
DIN EN IEC 60747-17 (VDE 0884-17)				
Maximum repetitive isolation voltage		V_{IORM}	2121	V_{PEAK}
Maximum working isolation voltage	AC Voltage	V_{IOWM}	1500	V_{RMS}
	DC Voltage		2121	V_{DC}
Apparent Charge	Method a, after Input/output safety test subgroup 2/3, $V_{ini}=V_{IOTM}$, $t_{ini} = 60\text{ s}$, $V_{pd(m)}=1.2*V_{IORM}$, $t_m=10\text{s}$.	q_{pd}	<5	pC
	Method a, after environmental tests subgroup 1, $V_{ini}=V_{IOTM}$, $t_{ini}=60\text{s}$, $V_{pd(m)}=1.6*V_{IORM}$, $t_m=10\text{s}$			pC
	Method b, $V_{ini}=1.2*V_{IOTM}$, $t_{ini}=1\text{s}$			pC

Description	Test Condition	Symbo l	Value	Unit
	$V_{pd(m)}=1.875 \cdot V_{IORM}$, $t_m=1s$ (method b1) or $V_{pd(m)}=V_{ini}$, $t_m=t_{ini}$ (method b2)			
Maximum transient isolation voltage	$t = 60sec$	V_{IOTM}	8000	V_{PEAK}
Maximum impulse voltage	Tested in air, 1.2/50 μ s waveform per IEC62368-1	V_{IMP}	6250	V_{PEAK}
Maximum Surge Isolation Voltage	Test method per IEC62368-1, 1.2/50 μ s waveform, $V_{IOSM} \geq V_{IMP} \times 1.3$	V_{IOSM}	10000	V_{PEAK}
Isolation resistance	$V_{IO} = 500V$, $T_{amb}=25^\circ C$	R_{IO}	$>10^{12}$	Ω
	$V_{IO} = 500V$, $100^\circ C \leq T_{amb} \leq 125^\circ C$	R_{IO}	$>10^{11}$	Ω
	$V_{IO} = 500V$, $T_{amb}=T_s$	R_{IO}	$>10^9$	Ω
Isolation capacitance	$f = 1MHz$	C_{IO}	0.8	pF
Safety total power dissipation	$V_I = 5.5V$, $T_J = 150^\circ C$, $T_A = 25^\circ C$	P_s	1524	mW
Safety input, output, or supply current	$\theta_{JA} = 82^\circ C/W$ for SOW8, $V_I = 5.5V$, $T_J = 150^\circ C$, $T_A = 25^\circ C$	I_s	277	mA
Maximum safety temperature		T_s	150	$^\circ C$
UL1577				
Insulation voltage per UL	$V_{TEST} = V_{ISO}$, $t = 60 s$ (qualification), $V_{TEST} = 1.2 \times V_{ISO}$, $t = 1 s$	V_{ISO}	5000	V_{RMS}

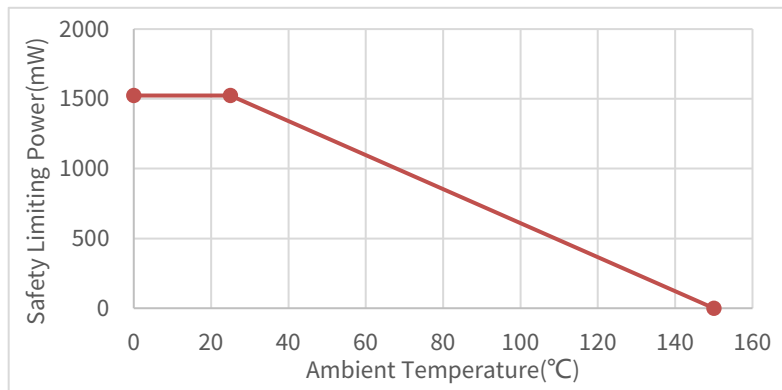

Figure 7.1 NSI3611D Thermal Derating Curve, Dependence of Safety Limiting Values with Case Temperature per DIN VDE V 0884-11

7.3. Regulatory Information

The NSI3611D are approved by the organizations listed in table.

UL	VDE	CQC	TUV	
UL 1577 Component Recognition Program	Approved under CSA Component Acceptance Notice 5A	DIN EN IEC 60747-17 (VDE 0884-17)	Certified according to GB4943.1	Certified According to EN IEC 62368-1
Single Protection, 5000V _{rms} Isolation voltage	Single Protection, 5000V _{rms} Isolation voltage	Reinforce Insulation V _{IORM} =2121 V _{PEAK} V _{IOTM} =8000 V _{PEAK} V _{IOSM} =10000 V _{PEAK}	Reinforced insulation	5000Vrms for 1min
E500602	E500602	40052820	CQC20001264939	R50574061

8. Function Description

8.1. Overview

The NSI3611D is a high-performance isolated amplifier with integrated isolated power supply. The device accepts a single-ended input signal range from 0V to 2V. The integrated isolated power supply enables single-power operation on the low side of the device without the need for a separate isolated power supply for the high side, effectively reducing the board area. The high input impedance of NSI3611D makes it highly suitable for connection to high-voltage resistive dividers or other voltage signal sources with high output resistance.

The low-side power supply VDD feeds power to the isolated power supply input through an LDO with external connection from the LDO pin to the ISO_PI pin. The output of the isolated power supply is regulated by an LDO with external connection from the ISO_PO pin to the LDO_IN pin, to power the high-side circuit. The integrated isolated power supply enables single-power operation on the low side of the device without the need for a separate isolated power supply for the high side, effectively reducing the board area.

The analog input is continuously sampled by a second-order Σ - Δ modulator in the device, which is driven by a pre-stage buffer in the device. With the internal voltage reference and clock generator, the modulator converts the analog input signal to a digital bitstream. The output of the modulator is transferred by the drivers (called TX in the Functional Block Diagram) across the isolation barrier that separates the isolated input and output side voltage. The received bitstream and clock are synchronized and processed, as shown in the Functional Block Diagram, by a fourth-order analog filter on the output side and has a differential output.

The integrated isolated power supply detection and the open-drain diagnosis output simplify system-level design and diagnostics.

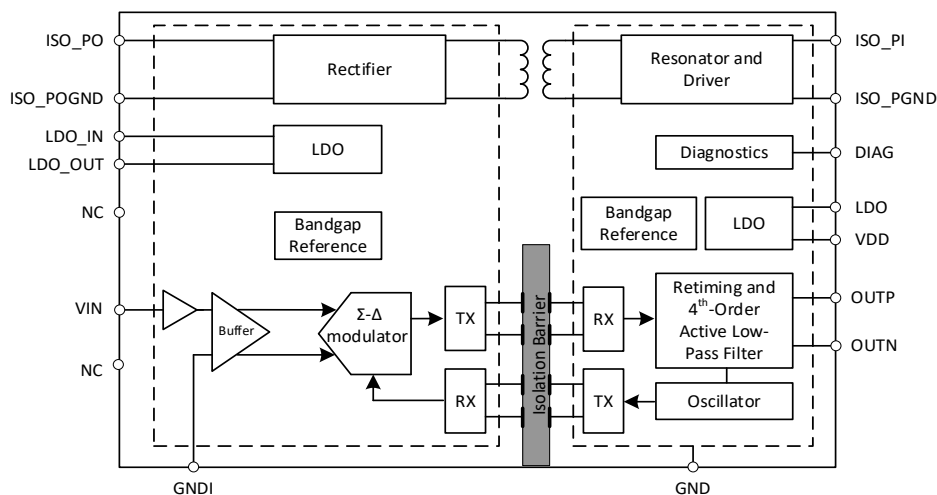

Figure 8.1 Function Block Diagram of NSI3611D

8.2. Analog Input and output

There are two restrictions on the analog input signal (VIN).

- If the input voltage exceeds the range GND1 – 6 V to VDD1 + 0.5 V, the input current must be limited to 10 mA because the device input electrostatic discharge (ESD) diodes turn on.
- The linearity and noise performance of the device are ensured only when the analog input voltage remains within the specified linear full-scale range (FSR).

For linear input range, the analog output of NSI3611D has a fixed gain of 1. If an input signal exceeding the clipping input range is applied to the NSI3611D ($V_{IN} \geq V_{Clipping}$), the analog output will be clipped (typically 2.4V).

In addition, NSI3611D integrates some diagnostic measures and offers a fail-safe output to simplify system-level design. The fail-safe output is a negative differential output voltage that does not occur under normal device operation, and it will only be activated when the undervoltage of the integrated isolated power supply output ISO_PO or the high-side LDO output LDO_OUT is detected. Use the maximum $V_{FAILSAFE}$ voltage -2.5V as a reference value for the fail-safe detection on the system level.

8.3. Accuracy Related Parameters

Parameters related to the accuracy performance are explained in this section, including Vos and its drift, EG and its drift, Nonlinearity. Other immunity parameters that affect accuracy like CMRR and PSRR are also included.

8.3.1. Input offset Vos and Gain Error EG

Vos and EG are the most significant factor influencing accuracy. The ideal curve and actual curve are shown in Figure 8.2.

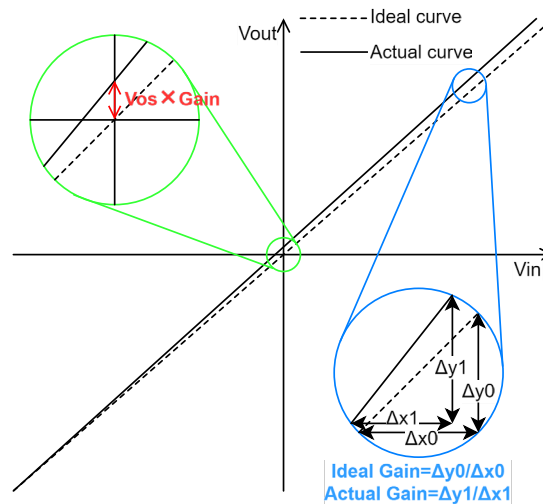

Figure 8.2 Vos and EG diagram

Vos means the input offset voltage when input is 0V. The tested output should be divided by nominal gain as Vos is defined as the offset voltage referred to input (See Equation 1).

$$Vos = Vo / \text{Nominal Gain} \tag{Equation 1}$$

where

- Vo is the output voltage tested when input is 0V.
- Nominal Gain is 1 for NSI3611D.

Gain is the magnification of the amplifier, and the definition formula is shown in Equation 2. EG means the difference between actual and ideal slope. It should be noted that EG is tested across the whole input range to minimize test error (See Equation 3).

$$\text{Gain} = \frac{\Delta y1}{\Delta x1} = \frac{Vo1 - Vo2}{Vin1 - Vin2} \tag{Equation 2}$$

$$E_G = \frac{\text{Gain} - \text{Nominal Gain}}{\text{Nominal Gain}} \times 100\% \quad \text{Equation 3}$$

where Vin1 and Vin2 are the lower and upper limit of the input FSR separately, Vo1 and Vo2 are the output voltage corresponding to Vin1 and Vin2.

8.3.2. Input offset drift TCV_{OS} and Gain error thermal drift TCE_G

Input offset drift TCV_{OS} means the drift of V_{OS} over the whole operating temperature range, which is calculated as Equation 4.

$$\text{TCV}_{OS} = \frac{V_{OS_{max}} - V_{OS_{min}}}{\text{TempRange}} \quad \text{Equation 4}$$

where

- V_{OS_{max}} and V_{OS_{min}} is the maximum and minimum offset voltage over the whole operating ambient temperature range.
- TempRange covers the whole operating temperature, from -40°C to 125°C.

Gain error thermal drift TCE_G is the drift of E_G over the whole operating temperature range, which is calculated as Equation 5.

$$\text{TCE}_G = \frac{E_{G_{max}} - E_{G_{min}}}{\text{TempRange}} \quad \text{Equation 5}$$

where E_{G_{max}} and E_{G_{min}} is the maximum and minimum Gain Error over the whole temperature.

Both TCV_{OS} and TCE_G should be multiplied by the direction of temperature drift.

8.3.3. Nonlinearity

Nonlinearity describes the deviation between the actual output and the ideal linear output. Calculate the peak-to-peak value of the error between the actual output and the fitting curve, and nonlinearity is expressed as the ratio of half of the peak-to-peak error to the full-scale range of the output voltage (See Equation 6).

$$\text{Nonlinearity} = \frac{\text{Error_pkpk}}{2 \times V_{OFSR}} \times 100\% \quad \text{Equation 6}$$

where

- Error_pkpk is the peak-to-peak value of the error between the actual output and the fitting curve.
- V_{OFSR} represents the full-scale range of the output voltage (2V for NSI3611D).

8.3.4. Power-Supply Rejection Ratio

Power-Supply Rejection Ratio (PSRR) describes the level of the output error (input inferred) which is affected by the variation of power supply. PSRR is defined in dB and calculated as Equation 7.

$$\text{PSRR} = 20 \times \log_{10} \left(\frac{V_{O_var}}{\text{Nominal Gain} \times V_{DD_var}} \right) \quad \text{Equation 7}$$

Where V_{O_{var}} and V_{DD_{var}} are respectively the variation value of the output voltage and the supply voltage.

8.3.5. Common-Mode Rejection Ratio

Common-Mode Rejection Ratio (CMRR) quantifies the ability of a differential amplifier to suppress the variation of the common mode signals while amplifying the differential-mode signals. CMRR is calculated as:

$$\text{CMRR} = 20 \times \log_{10} \left(\frac{V_{O_var}}{\text{Nominal Gain} \times V_{CM_var}} \right) \quad \text{Equation 8}$$

where CMRR is the input-referred voltage variation in dB and V_{CM_{var}} is the variation value of the input common-mode voltage.

8.3.6. Total Error Calculation

The total error is contributed by parameters discussed above. It is helpful to know the respective contribution of all different parameters when something is wrong about system current sensing. This section will introduce the calculation method of total error.

Parameters which mainly affects sensing accuracy are Vos, EG and Nonlinearity and their drift. PSRR and CMRR are not a dominant factor in most case. However, PSRR can be a concern when the power supply has high-frequency ripple, in which case a larger decoupling capacitor and a better layout is highly recommended (Refer to Section 9.3).

The error introduced by Vos and its drift can be calculated as:

$$\text{Error_Vos} = \frac{V_{os_{max}} + TCV_{os} \times \Delta T}{V_{IN}} \times 100\% \quad \text{Equation 9}$$

where

- Vos_{max} is the maximum value of input offset voltage at 25°C, which is ±1.2mV for NSI3611D.
- TCV_{os} is the maximum drift of input offset voltage over the whole working temperature, which is 20uV/°C for 3611D
- ΔT is the range of temperature variation.
- V_{IN} is the input voltage in the application.

The error introduced by EG and TCE_G can be calculated as:

$$\text{Error_EG} = E_G + TCE_G \times \Delta T \quad \text{Equation 10}$$

where

- EG is the maximum value of Gain Error when the temperature is 25°C, which is ±0.25% for NSI3611D.
- TCE_G is the maximum drift of Gain Error over the whole temperature, which is ±50ppm/°C for NSI3611D.

The error introduced by Nonlinearity is Nonlinearity_{max}, the maximum value of Nonlinearity in the entire temperature range, - 40°C to 125°C, which is ±0.04% for NSI3611D. The total error sensing error is expressed as:

$$\text{Total_Error} = \sqrt{\text{Error_Vos}^2 + \text{Error_EG}^2 + \text{Nonlinearity}_{max}^2} \quad \text{Equation 11}$$

For example, consider an NSI3611D with the sensing input voltage of 0~2V and a - 40°C to 85°C temperature range. The total error calculation is shown in Table 8.1.

Table 8.1 Total Error Calculation of NSI3611D (- 40°C to 85°C)

Error Component	Symbol	Equation	Error at Vin=2V	Error at Vin=0.1V
Input offset error	Error_Vos	$\text{Error_Vos} = \frac{V_{os_{max}} + TCV_{os} \times \Delta T}{V_{IN}} \times 100\%$ $= \frac{\pm 1.2\text{mV} \pm 30\mu\text{V}/^\circ\text{C} \times 65^\circ\text{C}}{V_{IN}} \times 100\%$	±0.158%	±3.15%
Gain error	Error_EG	$\text{Error_EG} = E_G + TCE_G \times \Delta T$ $= \pm 0.25\% \pm 45\text{ppm}/^\circ\text{C} \times 65^\circ\text{C}$	±0.543%	±0.543%
Nonlinearity	Nonlinearity _{max}	Nonlinearity _{max} = ±0.04%	±0.04%	±0.04%
Total error	Total_Error	$\text{Total_Error} = \sqrt{\text{Error_Vos}^2 + \text{Error_EG}^2 + \text{Nonlinearity}_{max}^2}$	±0.567%	±3.197%

Since the input offset voltage is independent of input voltage, it becomes the dominant factor of the total error when the input voltage is low. To improve the system accuracy, especially under low-input applications, it is recommended to perform software zero-point calibration and gain error calibration. With system-level calibration, the total error can also be reduced significantly. The reduced error is calculated as Table 8.2.

Table 8.2 Total Error Calculation with Software Calibration (- 40°C to 85°C)

Error Component	Symbol	Equation	Error at Vin=2V	Error at Vin=0.1V
Input offset error	Error_Vos	$\text{Error_Vos} = \frac{\text{TCV}_{os} \times \Delta T}{V_{IN}} \times 100\%$ $= \frac{30\mu\text{V}/^\circ\text{C} * 65^\circ\text{C}}{V_{IN}} \times 100\%$	±0.098%	±1.95%
Gain error	Error_EG	$\text{Error_EG} = \text{TCE}_G \times \Delta T = \pm 45\text{ppm}/^\circ\text{C} \times 65^\circ\text{C}$	±0.293%	±0.293%
Nonlinearity	Nonlinearity _{max}	$\text{Nonlinearity}_{\text{max}} = \pm 0.04\%$	±0.04%	±0.04%
Total error	Total_Error	$\text{Total_Error} = \sqrt{\text{Error_Vos}^2 + \text{Error_EG}^2 + \text{Nonlinearity}_{\text{max}}^2}$	±0.312%	±1.972%

The maximum total error with and without calibration is show in Figure 8.3.

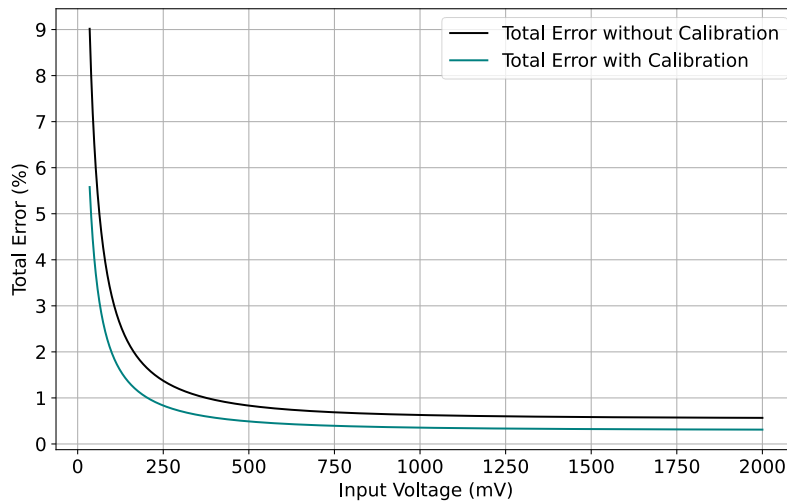

Figure 8.3 Total Error Over - 40°C to 85°C vs Input Voltage

8.4. Isolated power

The NSI3611D integrates an isolated DC/DC power supply that includes the following components as shown in Figure 8.1:

- Low-side low-dropout regulator (LDO) to provide stable voltage for the input of the isolated DC/DC converter.
- Isolated DC/DC converter with the primary resonator and driver, an air-core transformer, and the secondary rectifier. The converter does not output a constant voltage and it is not recommended to drive additional load.
- High-side LDO to convert the isolated DC/DC converter output to a stable voltage and supply for the high-side signal circuitry. The high-side LDO can provide a limited current of 1mA for external load.

The isolated DC/DC power supply uses a spread spectrum clocking technique and optimized transformer design to improve the electro-magnetic interference (EMI) performance.

8.5. Diagnostic Output

The open-drain diagnosis output DIAG helps confirm whether the device is in normal operation and simplifies system-level design and diagnostics. The DIAG pin needs to be connected to the pull-up supply through a resistor. If the device operates normally, the DIAG pin is in a high-impedance state and pulled up to high level externally. The DIAG pin is actively pulled

low when the undervoltage of the integrated isolated power supply output ISO_PO or the high-side LDO output LDO_OUT is detected. The failsafe mode is activated correspondingly. The amplifier outputs a negative differential voltage V_{FAILSAFE} .

The diagnostic output feature is only activated when the NSI3611D is properly powered on, which means the DIAG pin will not be pull down during power up procedure.

The DIAG pin can be floating if not used.

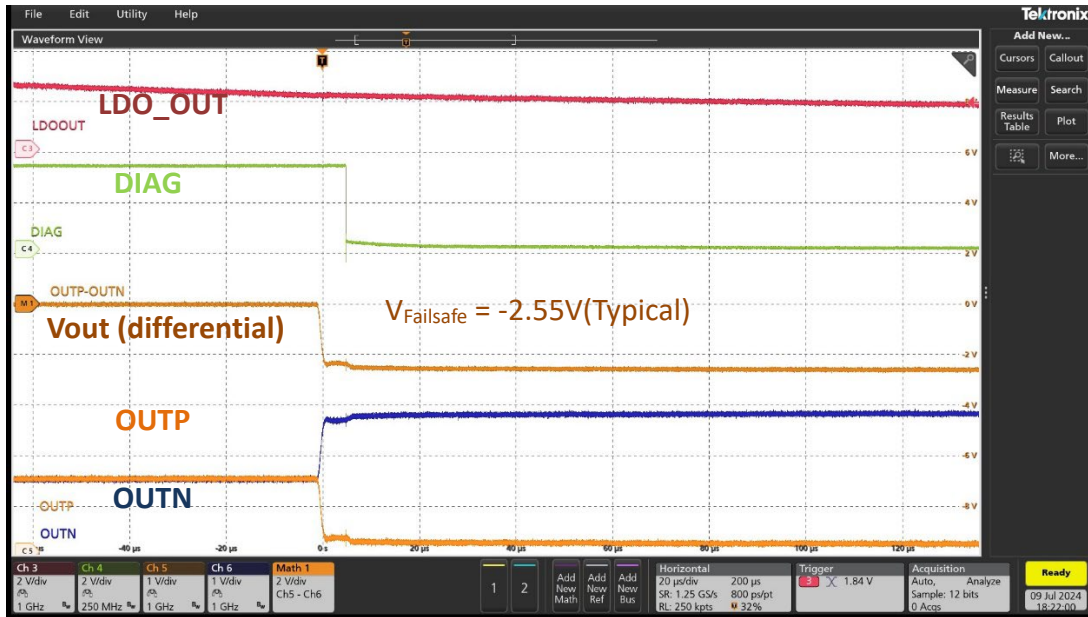

Figure 8.4 Typical Failsafe output

9. Application Note

9.1. Typical Application Circuit

The following key features make NSI3611D is the ideal solution for isolated voltage sensing applications.

- Reinforced isolation barrier supports a working voltage up to 1500Vrms, provide extremely high reliability for dangerous high voltage systems.
- Excellent common mode transient immunity (CMTI, 150kV/us typ) ensures the device to provide accurate and reliable measurements even in the presence of high-power switching.
- Isolated power supply integrated, reduces the need of external isolated high-side supply compared to traditional [NSI1311-Q1](#), simplifies design and reduces area.
- Excellent DC accuracy and low drift, high linearity over FSR, make sure the device can provide extremely high sensing accuracy.

The typical application circuit is shown in Figure 9.1. The output of the low-side LDO (LDO pin) need to be connected to the isolated power supply input (ISO_PI pin). The isolated power supply output (ISO_PO pin) need to be connected to the input of the high-side LDO (LDO_IN pin). In this way, the high-side amplifier circuitry is powered by an isolated power supply. The necessary filter and bypass capacitors should be added to the device power supply, the isolated power supply input (ISO_PI pin) and output (ISO_PO pin), and the input of the high-side LDO (LDO_IN pin).The recommended capacitance can refer to Figure 9.1.

The bus voltage of the frequency inverter is divided by a resistance network, and the divided voltage is applied to the input of the NSI3611D through a RC filter. Suggest to add >1kΩ resistor on the OUP and OUTN pin to prevent output over-current. An analog-to-digital converter usually receives the analog output and converts to digital signal for controller processing.

- Keep the trace lengths of the wiring as short as possible and don't place a ground plane in the high-voltage domain, which minimizes the antenna on this node to minimize radiated emissions.

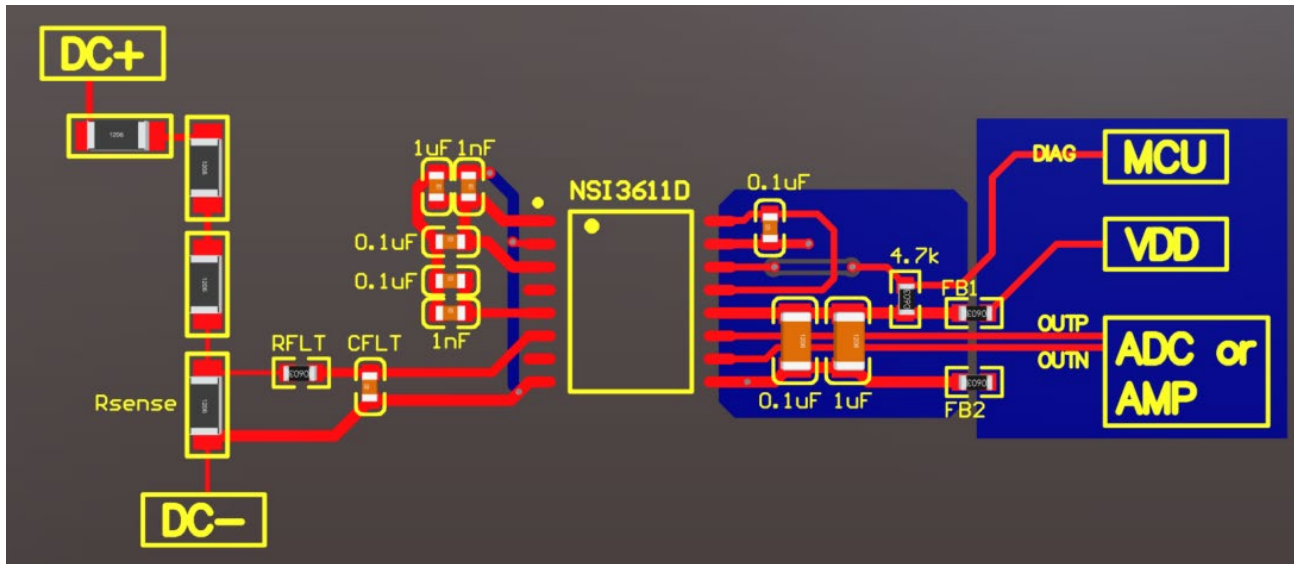
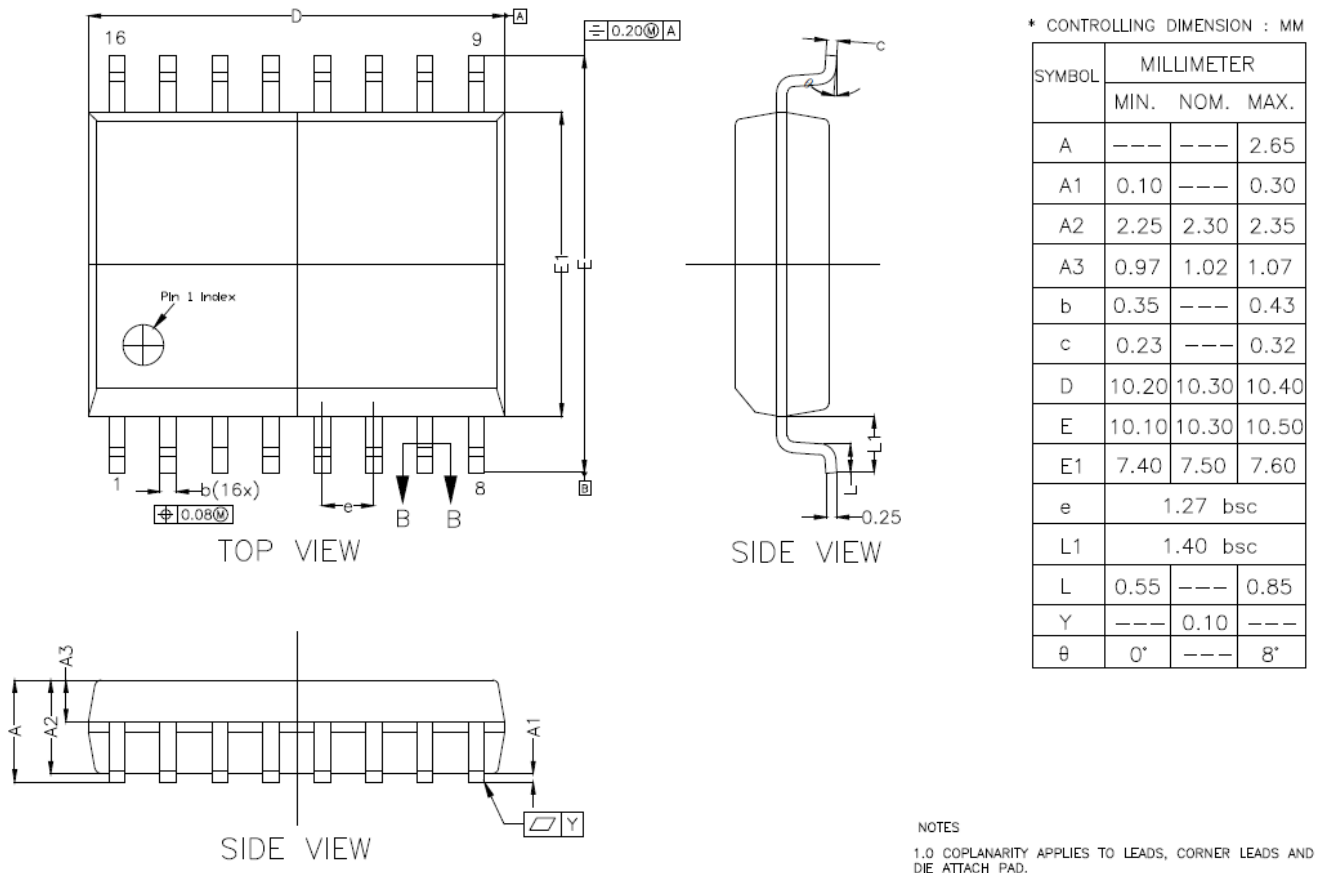

Figure 9.2 PCB layout example of NSI3611D

10. Package Information



NOTE: This dimension does not include mold flash, protrusions, or gate burrs. Mold flash, protrusions, or gate burrs shall not exceed 0.15 mm, per side.

Figure 10.1 SOW16 package shape and dimension in millimeters

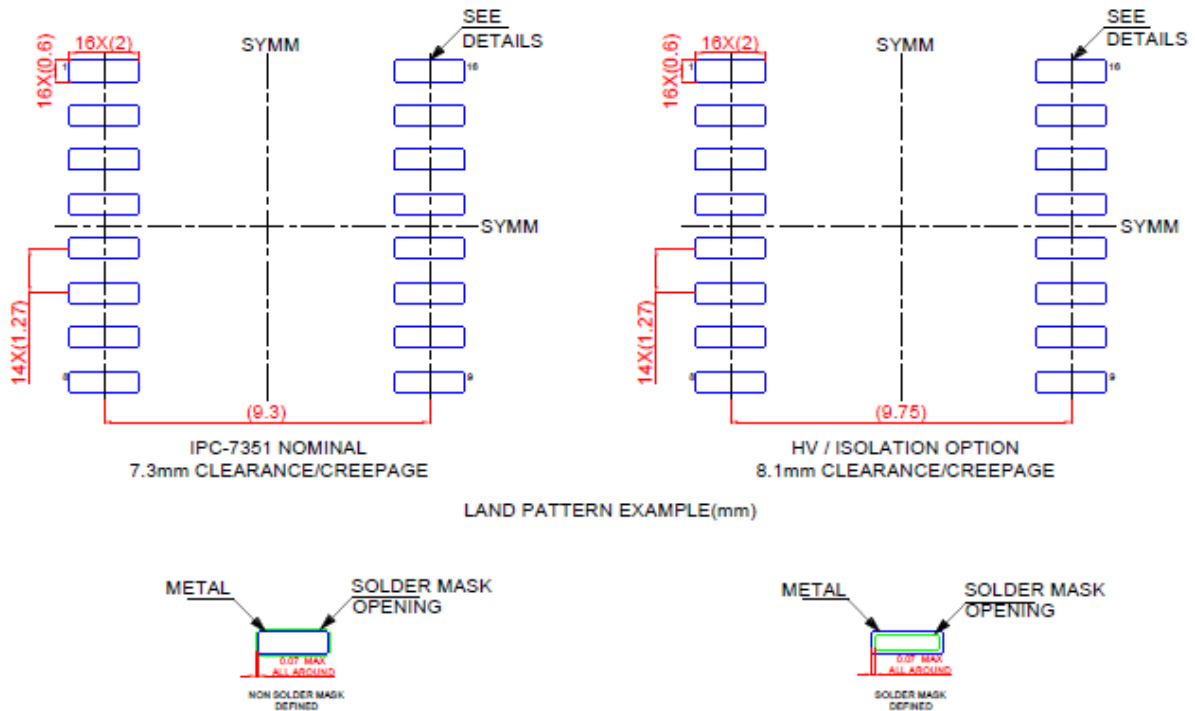

Figure 10.2 SOW16 Package Board Layout Example

11. Ordering Information

Part No.	Isolation Rating (kV)	Linear Input Range(V)	Moisture Sensitivity Level	Temperature	Automotive	Package Type	Package Drawing	SPQ
NSI3611D-Q1SWR	5	0 ~ 2	Level-3	-40 to 125°C	YES	SOP16 (300mil)	SOW16	1500

12. Documentation Support

Part Number	Product Folder	Datasheet	Technical Documents	Isolator selection guide
NSI3611D-Q1	Click here	Click here	Click here	Click here

13. Tape and Reel Information

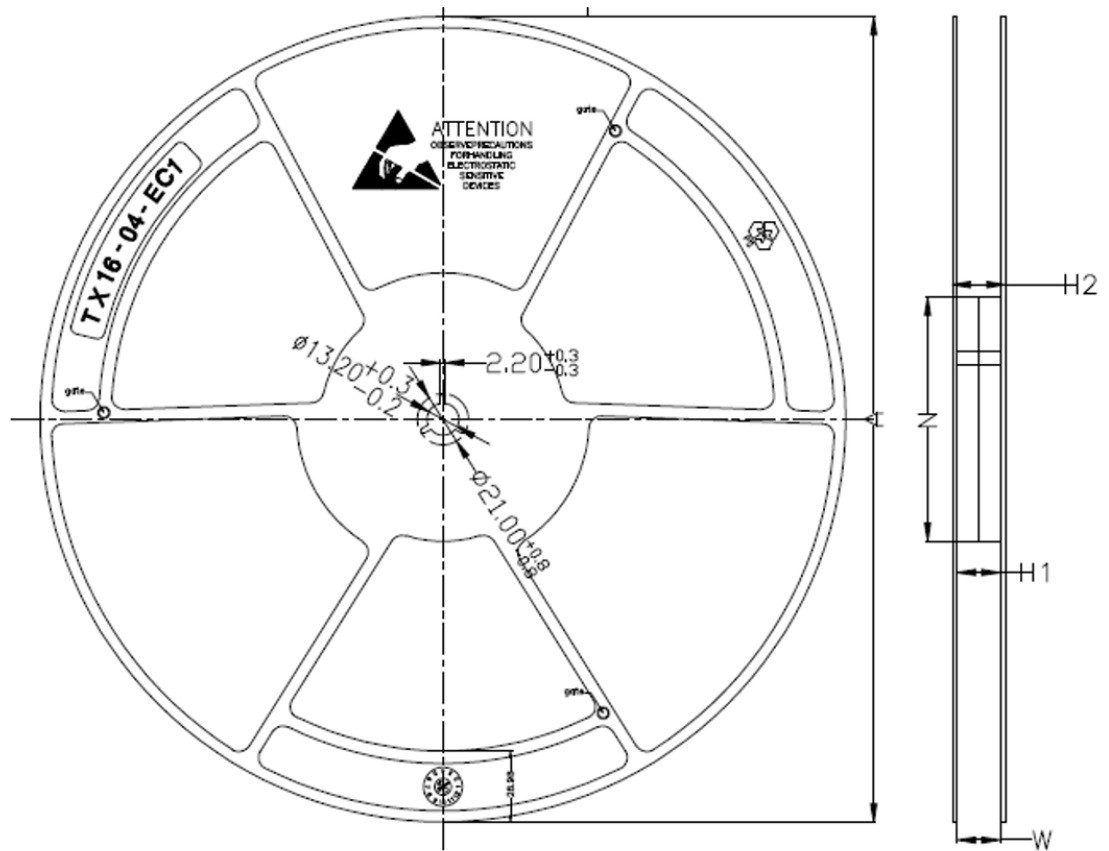

- NOTES:**
 1. MATERIAL: DISSIPATIVE (BLACK)
 2. FLANGE WARPAGE: 3 MM MAXIMUM \pm
 3. ALL DIMENSIONS ARE IN MM
 4. ESD - SURFACE RESISTIVITY - 10 TO 10 OHMS/SQ
 5. GENERAL TOLERANCE: ± 0.25 MM

PRODUCT SPECIFICATIONS					
TAPE WIDTH	$\phi A \begin{smallmatrix} +2 \\ -2 \end{smallmatrix}$	$\phi N \begin{smallmatrix} +2 \\ -2 \end{smallmatrix}$	$H1 \begin{smallmatrix} +2 \\ -0 \end{smallmatrix}$	$H2 \begin{smallmatrix} +1 \\ -1 \end{smallmatrix}$	$W \begin{smallmatrix} +3.5 \\ -0.2 \end{smallmatrix}$
16MM	330	100	16.4	20.6	16.4

Figure 13.1 Reel Information

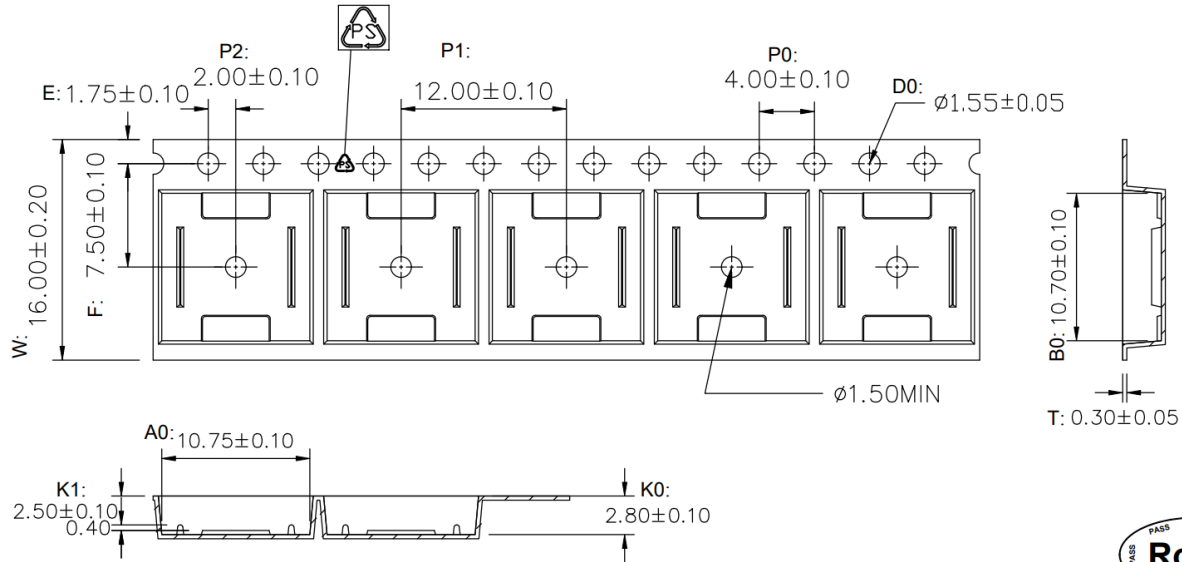

1. 10 sprocket hole pitch cumulative tolerance ± 0.20 .
2. Carrier camber is within 1 mm in 250 mm.
3. Material : Black Conductive Polystyrene Alloy .
4. All dimensions meet EIA-481 requirements.
5. Thickness : 0.30 ± 0.05 mm.
6. Packing length per 22" reel : 378 Meters.(復巻 N=122)
7. Component load per 13" reel : 1000 pcs.
8. Surface resistivity : $10^5 \sim 10^{10} \Omega/\square$

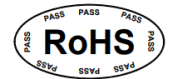

W	16.00±0.20
A0	10.75±0.10
B0	10.70±0.10
K0	2.80±0.10
K1	2.50±0.10

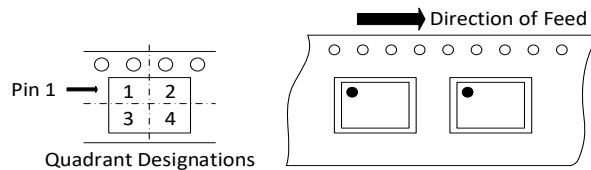

Figure 13.2 Tape Information of SOP16(300mil)

14. Revision History

Revision	Description	Date
1.0	Initial Version.	2025/12/7

IMPORTANT NOTICE

The information given in this document (the “Document”) shall in no event be regarded as any warranty or authorization of, express or implied, including but not limited to accuracy, completeness, merchantability, fitness for a particular purpose or infringement of any third party’s intellectual property rights.

Users of this Document shall be solely responsible for the use of NOVOSENSE’s products and applications, and for the safety thereof. Users shall comply with all laws, regulations and requirements related to NOVOSENSE’s products and applications, although information or support related to any application may still be provided by NOVOSENSE.

This Document is provided on an “AS IS” basis, and is intended only for skilled developers designing with NOVOSENSE’s products. NOVOSENSE reserves the rights to make corrections, modifications, enhancements, improvements or other changes to the products and services provided without notice. NOVOSENSE authorizes users to use this Document exclusively for the development of relevant applications or systems designed to integrate NOVOSENSE’s products. No license to any intellectual property rights of NOVOSENSE is granted by implication or otherwise. Using this Document for any other purpose, or any unauthorized reproduction or display of this Document is strictly prohibited. In no event shall NOVOSENSE be liable for any claims, damages, costs, losses or liabilities arising out of or in connection with this Document or the use of this Document.

For further information on applications, products and technologies, please contact NOVOSENSE (www.novosns.com).

Suzhou NOVOSENSE Microelectronics Co., Ltd