

Product Overview

NSI1311-Q1 is a high-performance isolated amplifier with output separated from input based on the NOVOSENSE capacitive isolation technology. The device has a single-ended input signal range from 0.02V to 2V. The high input impedance of NSI1311-Q1 makes it highly suitable for connection to high-voltage resistive dividers or other voltage signal sources with high output resistance.

The device has a fixed gain of 1 and provides a differential analog output.

The low offset and gain drift ensure the accuracy over the entire temperature range. The high common-mode transient immunity ensures that the device is able to provide accurate and reliable measurements even in the presence of high-power switching such as in motor control applications.

The fail-safe function (missing VDD1 detection) simplifies system-level design and diagnostics.

Key Features

- Up to 5700V_{rms} Insulation voltage
- 0.02~2V, High-Impedance Input Voltage Range
- Fixed Gain: 1
- Low Offset Error and Drift:
 - ±1.5mV (Max), -5~30µV/°C (Max)
- Low Gain Error and Drift:
 - ±0.3% (Max), ±45ppm/°C (Max)
- Low Nonlinearity and Drift:
 - ±0.05% (Max) for 0.02V~0.1V VIN
 - ±0.04% (Max) for 0.1V~2V VIN
 - ±1ppm/°C (Typ)
- SNR: 82dB (Typ, BW=10kHz), 70dB (Typ, BW=100kHz)
- Wide bandwidth: 400kHz (Typ)

- High CMTI: 150kV/µs (Typ)
- System-Level Diagnostic Feature:
 - VDD1 monitoring
- Operation Temperature: -40°C~125°C
- AEC-Q100 qualified for automotive applications
- RoHS-Compliant Packages:
 - SOP-8(300mil)

Safety Regulatory Approvals

- UL recognition per UL1577
- CQC certification per GB4943.1
- CSA component notice 5A
- DIN EN IEC 60747-17 (VDE 0884-17)

Applications

- Bus voltage monitoring
- AC motor controls
- Power and solar inverters
- Uninterruptible Power Suppliers
- Automotive onboard chargers

Device Information

Part Number	Package	Body Size
NSI1311-Q1SWVR	SOP8(300mil)	5.85mm × 7.50mm

Functional Block Diagrams

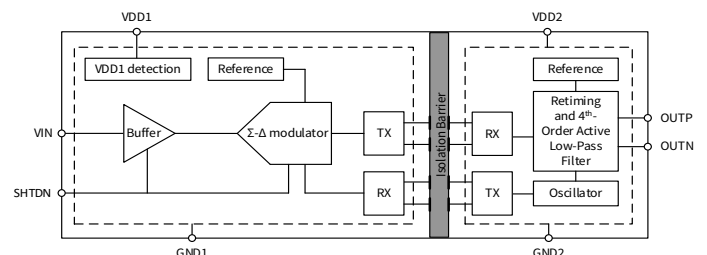

Figure 1. Block Diagram

INDEX

1. PIN CONFIGURATION AND FUNCTIONS.....	3
2. ABSOLUTE MAXIMUM RATINGS	4
3. RECOMMENDED OPERATING CONDITIONS.....	4
4. THERMAL INFORMATION	4
5. SPECIFICATIONS.....	5
5.1. ELECTRICAL CHARACTERISTICS	5
5.2. TYPICAL PERFORMANCE CHARACTERISTICS	6
5.3. PARAMETER MEASUREMENT INFORMATION.....	8
6. HIGH VOLTAGE FEATURE DESCRIPTION	8
6.1. INSULATION AND SAFETY RELATED SPECIFICATIONS.....	8
6.2. INSULATION CHARACTERISTICS	9
6.3. REGULATORY INFORMATION.....	10
7. FUNCTION DESCRIPTION	10
7.1. OVERVIEW.....	10
7.2. ANALOG INPUT	11
7.3. ANALOG OUTPUT.....	11
8. APPLICATION NOTE.....	12
8.1. TYPICAL APPLICATION CIRCUIT.....	12
8.2. SENSE RESISTOR SELECTION	12
8.3. PCB LAYOUT.....	12
9. PACKAGE INFORMATION	13
10. ORDERING INFORMATION	14
11. DOCUMENTATION SUPPORT	14
12. TAPE AND REEL INFORMATION	15
13. REVISION HISTORY.....	16

1. Pin Configuration and Functions

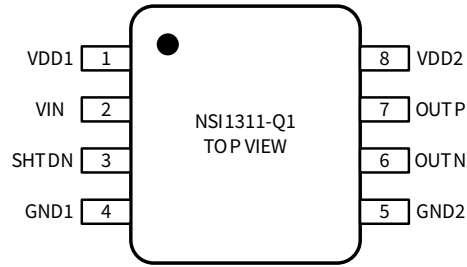

Figure 1.1 Package

Table 1.1 Pin Configuration and Description

NSI1311 PIN NO.	SYMBOL	FUNCTION
1	VDD1	Power supply for isolator side 1(3.0V to 5.5V)
2	VIN	Analog input
3	SHTDN	Shutdown input, active high, pulled up internally (typical resistor value: 100kΩ)
4	GND1	Ground 1, the ground reference for Isolator Side 1
5	GND2	Ground 2, the ground reference for Isolator Side 2
6	OUTN	Negative output
7	OUTP	Positive output
8	VDD2	Power supply for isolator side 2 (3.0V to 5.5V)

2. Absolute Maximum Ratings

Parameters	Symbol	Min	Typ	Max	Unit
Power Supply Voltage	VDD1, VDD2	-0.3		6.5	V
Input Voltage	VIN	GND1-6		VDD1+0.5	V
	SHTDN	GND1-0.5		VDD1+0.5	
Output Voltage	OUTP, OUTN	GND2-0.5		VDD2+0.5	V
Output current per Output Pin	Io	-10		10	mA
Operating Temperature	T _{OPR}	-40		125	°C
Junction Temperature	T _J	-40		150	°C
Storage Temperature	T _{STG}	-55		150	°C
Electrostatic discharge	HBM ⁽¹⁾	±2000			V
	CDM ⁽²⁾	±1000			V

(1) Human body model (HBM), per AEC-Q100-002-RevD

(2) Charged device model (CDM), per AEC-Q100-011-RevB

3. Recommended Operating Conditions

Parameters	Symbol	Min	Typ	Max	Unit
Side1 Power Supply	VDD1	3.0	5.0	5.5	V
Side2 Power Supply	VDD2	3.0	3.3	5.5	V
Differential input voltage before clipping output	V _{Clipping}		2.56		V
Linear differential input full scale voltage	V _{FSR}	0.02		2	V
Digital input voltage	SHTDN	GND1		VDD1	
Operating Ambient Temperature	T _A	-40		125	°C

4. Thermal Information

Parameters	Symbol	SOP8(300mil)	Unit
Junction-to-ambient thermal resistance	R _{θJA}	86	°C/W
Junction-to-case (top) thermal resistance	R _{θJC(top)}	28	°C/W
Junction-to-board thermal resistance	R _{θJB}	42	°C/W
Junction-to-top characterization parameter	Ψ _{JT}	4	°C/W
Junction-to-board characterization parameter	Ψ _{JB}	42	°C/W

5. Specifications

5.1. Electrical Characteristics

(VDD1 = 3.0V~5.5V, VDD2 = 3.0V~5.5V, VIN = 0.02V to 2V, and SHTDN = GND1 = 0V, TA = -40°C to 125°C. Unless otherwise noted, Typical values are at VDD1 = 5V, VDD2 = 3.3V, TA = 25°C)

Parameters	Symbol	Min	Typ	Max	Unit	Comments
Power Supply						
Side1 Supply Voltage	VDD1	3.0	5.0	5.5	V	
Side2 Supply Voltage	VDD2	3.0	3.3	5.5	V	
Side1 Supply Current	IDD1		11.4	15.1	mA	SHTDN = LOW
			0.001	1	mA	SHTDN = HIGH
Side2 Supply Current	IDD2		6.3	8.4	mA	
VDD1 undervoltage detection threshold voltage	VDD1 _{UV}	1.8	2.3	2.7	V	VDD1 falling
Analog Input						
Input offset voltage	V _{OS}	-1.5	±0.4	1.5	mV	Ta=25°C, VIN = 1V
Input offset drift	TCV _{OS}	-5	10	30	µV/°C	
Input resistance	R _{IN}		1		GΩ	
Input capacitance	C _{IN}		7		pF	f _{IN} = 275kHz
Input bias current	I _{IB}	-15	3.5	15	nA	Ta=25°C, VIN = GND1
Input bias current drift	TCI _{IB}		±10		pA/°C	
Analog Output						
Nominal Gain			1		V/V	
Gain error	E _G	-0.3%	±0.05%	0.3%		Ta=25°C
Gain error thermal drift	TCE _G	-45	±5	45	ppm/°C	
Nonlinearity		-0.05%	±0.01%	0.05%		Ta=25°C, 0.02V ≤ VIN ≤ 0.1V
		-0.04%	±0.01%	0.04%		Ta=25°C, 0.1V ≤ VIN ≤ 2V
Nonlinearity drift			±1		ppm/°C	
Total harmonic distortion	THD		-87		dB	VIN = 1.8V, f _{IN} = 10kHz, BW = 100kHz
Output noise			210		µV _{RMS}	VIN = 1V, BW = 100kHz
Signal to noise ratio	SNR	78	82		dB	VIN = 1.8V, f _{IN} = 1kHz, BW = 10kHz

Parameters	Symbol	Min	Typ	Max	Unit	Comments
			70		dB	V _{IN} = 1.8V, f _{IN} = 10kHz, BW = 100kHz
Common-mode output voltage	V _{CMout}	1.35	1.4	1.46	V	
Failsafe differential output voltage	V _{FAILSAFE}		-2.53	-2.44	V	SHTDN active, or VDD1 missing
Output Bandwidth	BW		400		kHz	
Power supply rejection ratio ⁽¹⁾	PSRR _{dc}		-78		dB	PSRR vs VDD1, at DC
	PSRR _{ac}		-75		dB	PSRR vs VDD1, 100mV and 10kHz ripple
	PSRR _{dc}		-82		dB	PSRR vs VDD2, at DC
	PSRR _{ac}		-74		dB	PSRR vs VDD2, 100mV and 10kHz ripple
Output resistance	R _{OUT}		<0.2		Ω	
Common-mode transient immunity	CMTI	100	150		kV/μs	Common-mode transient immunity
Digital Input (SHTDN)						
Input current	I _{IN}	-70		1	μA	GND1 ≤ V _{SHTDN} ≤ VDD1
Input capacitance	C _{IN}		5		pF	
High-level input voltage	V _{IH}	0.7*V _{D1}		VDD1+0.3	V	
Low-level input voltage	V _{IL}	-0.3		0.3*VDD1	V	
Timing						
Rising time of OUTP, OUTN	t _r		1.3		μs	
Falling time of OUTP, OUTN	t _f		1.3		μs	
INP, INN to OUTP, OUTN signal delay (50% - 50%)	t _{PD}		1.6	2.1	μs	
Analog setting time	t _{AS}		0.5		ms	VDD1 step to 3.0 V with VDD2 ≥ 3.0 V, to OUTP, OUTN valid, 0.1% settling
Device enable time	t _{EN}		80	100	μs	SHTDN high to low
Shutdown time	t _{SHTDN}		1.2	5	μs	SHTDN low to high

(1) Input referred.

5.2. Typical Performance Characteristics

Unless otherwise noted, test at VDD1 = 5V, VDD2 = 3.3V, 0.02V to 2V, and SHTDN = GND1 = 0V, f_{IN} = 1kHz, BW = 10kHz.

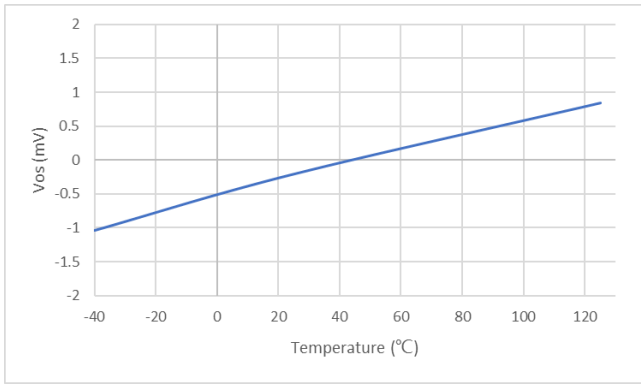

Figure 5.1 Input Offset Voltage vs Temperature

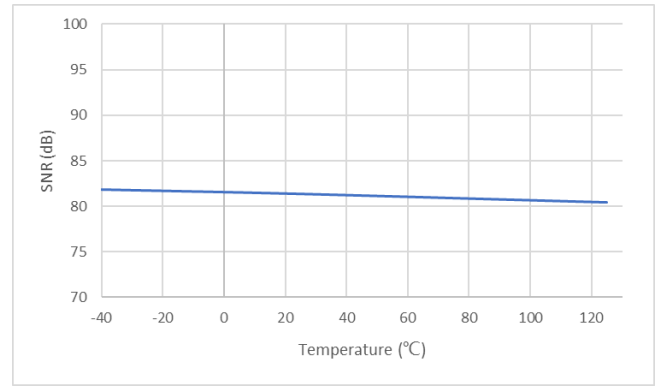

Figure 5.5 Signal-to-Noise Ratio vs Temperature

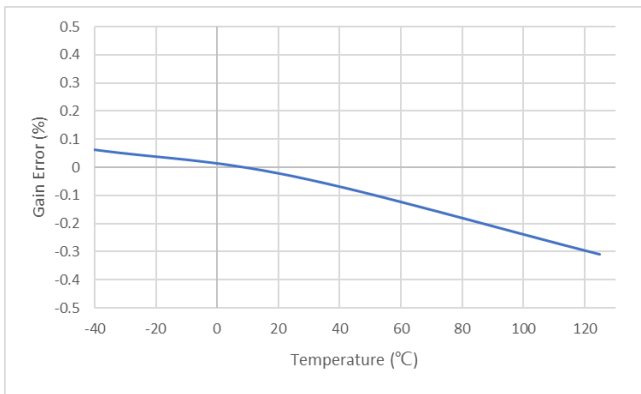

Figure 5.2 Gain Error vs Temperature

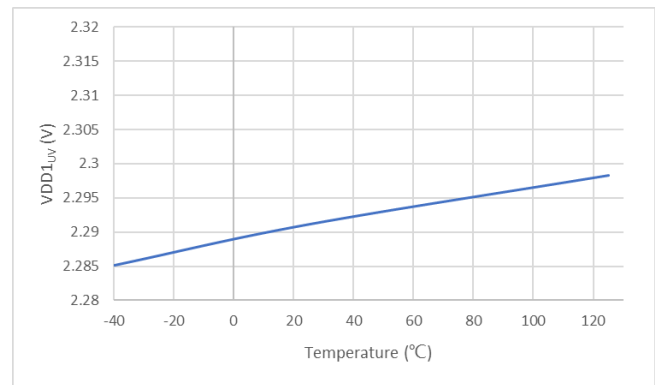

Figure 5.6 UVLO of VDD1 vs Temperature

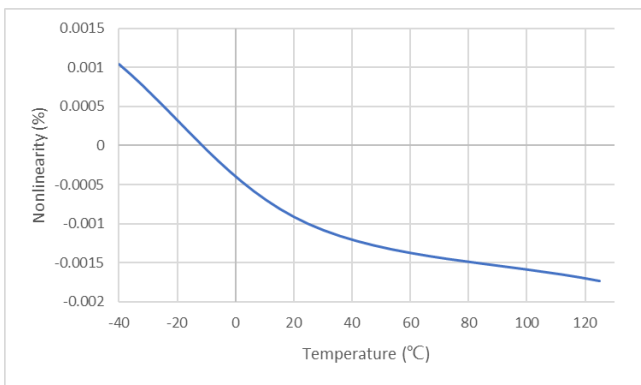

Figure 5.3 Nonlinearity vs Temperature

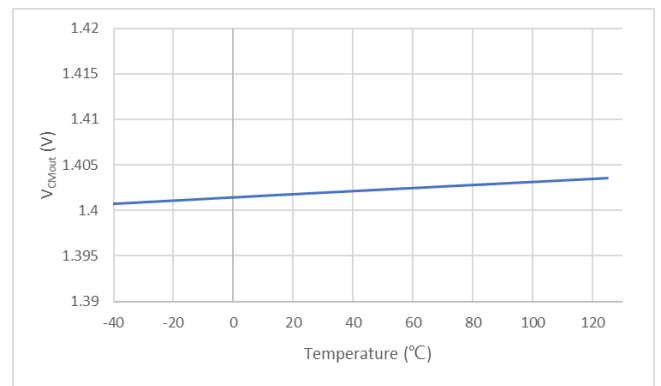

Figure 5.7 Output Common-Mode Voltage vs Temperature

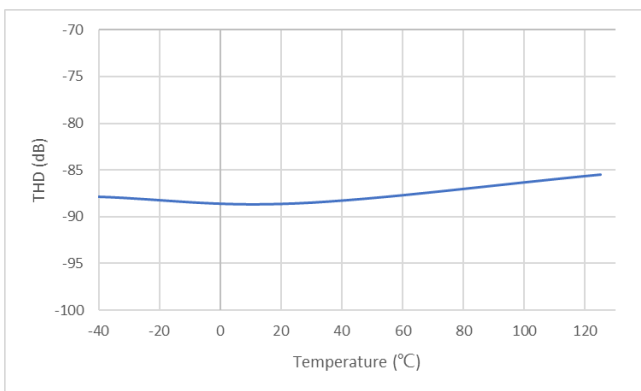

Figure 5.4 Total Harmonic Distortion vs Temperature

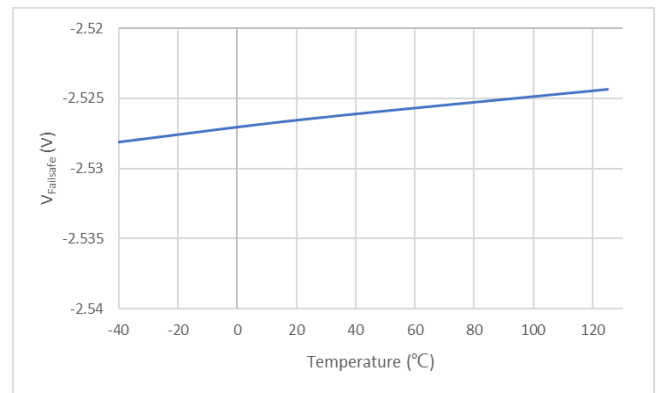

Figure 5.8 Fail-Safe Output Voltage vs Temperature

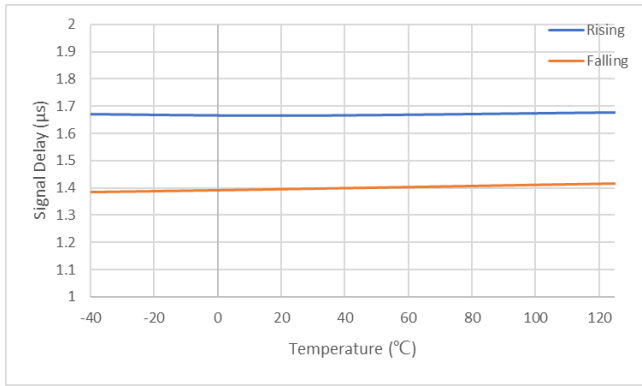

Figure 5.9 Vin to Vout Delay vs Temperature

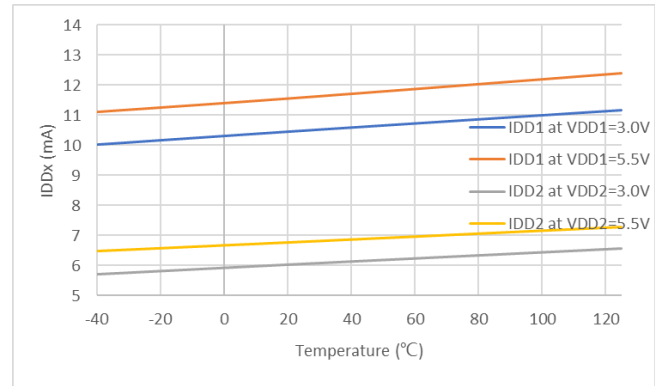

Figure 5.11 Supply Current vs Temperature

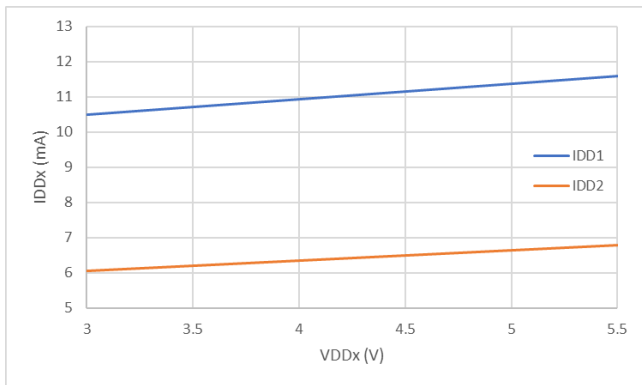

Figure 5.10 Supply Current vs Supply Voltage

5.3. Parameter Measurement Information

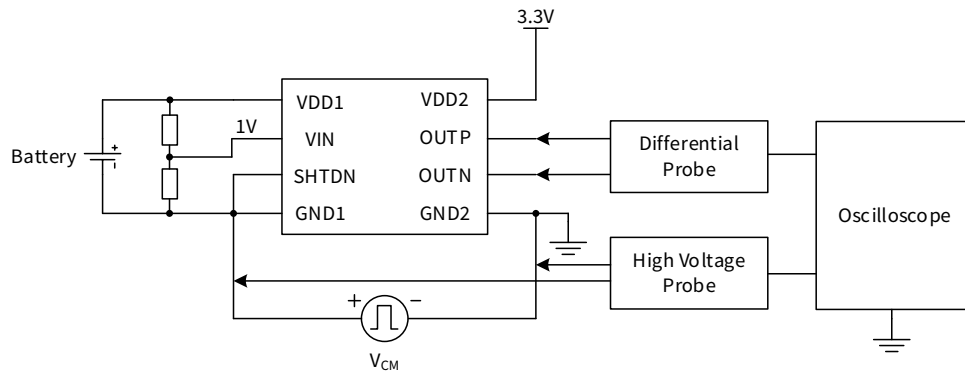

Figure 5.1212 Common-Mode Transient Immunity Test Circuit

6. High Voltage Feature Description

6.1. Insulation and Safety Related Specifications

Parameters	Symbol	Value	Unit	Comments
Minimum External Clearance	CLR	8	mm	IEC 60664-1:2007
Minimum External Creepage	CPG	8	mm	IEC 60664-1:2007
Distance Through Insulation	DTI	28	μm	Distance through insulation
Tracking Resistance (Comparative Tracking Index)	CTI	>600	V	DIN EN 60112 (VDE 0303-11); IEC 60112

Parameters	Symbol	Value	Unit	Comments
Material Group		I		IEC 60664-1

Description	Test Condition	Value
Overvoltage Category per IEC60664-1	For Rated Mains Voltage $\leq 150V_{rms}$	I to IV
	For Rated Mains Voltage $\leq 300V_{rms}$	I to IV
	For Rated Mains Voltage $\leq 600V_{rms}$	I to IV
Climatic Classification		40/125/21
Pollution Degree per DIN VDE 0110, Table 1		2

6.2. Insulation Characteristics

Description	Test Condition	Symbol	Value	Unit
Maximum repetitive isolation voltage		V_{IORM}	2121	V_{PEAK}
Maximum working isolation voltage	AC Voltage	V_{IOWM}	1500	V_{RMS}
	DC Voltage		2121	V_{DC}
Apparent Charge	Method a, after Input/output safety test subgroup 2/3, $V_{ini}=V_{IOTM}$, $t_{ini} = 60 s$, $V_{pd(m)}=1.2*V_{IORM}$, $t_m=10s$.	q_{pd}	<5	pC
	Method a, after environmental tests subgroup 1, $V_{ini}=V_{IOTM}$, $t_{ini}=60s$, $V_{pd(m)}=1.6*V_{IORM}$, $t_m=10s$			
	Method b, routine test (100% production) and preconditioning (type test); $V_{ini}=1.2*V_{IOTM}$, $t_{ini}=1s$ $V_{pd(m)}=1.875*V_{IORM}$, $t_m=1s$ (method b1) or $V_{pd(m)}=V_{ini}$, $t_m=t_{ini}$ (method b2)			
Maximum impulse voltage	Tested in air, 1.2/50-us waveform per IEC62368-1	V_{IMP}	6250	V_{PEAK}
Maximum Surge Isolation Voltage	Test method per IEC62368-1, 1.2/50us waveform, $V_{IOSM} \geq V_{IMP} \times 1.3$	V_{IOSM}	10000	V_{PEAK}
Isolation resistance	$V_{IO} =500V$, $T_{amb}=25^{\circ}C$	R_{IO}	$>10^{12}$	Ω
	$V_{IO} =500V$, $100^{\circ}C \leq T_{amb} \leq 125^{\circ}C$	R_{IO}	$>10^{11}$	Ω
	$V_{IO} =500V$, $T_{amb}=T_s$	R_{IO}	$>10^9$	Ω
Isolation capacitance	$f = 1MHz$	C_{IO}	0.8	pF
Safety total power dissipation	$V_I = 5.5V$, $T_J = 150^{\circ}C$, $T_A = 25^{\circ}C$	P_s	1430	mW

Description	Test Condition	Symbol	Value	Unit
Safety input, output, or supply current	$V_I = 5.5V, T_J = 150\text{ }^\circ\text{C}, T_A = 25\text{ }^\circ\text{C}$	I_S	260	mA
Maximum safety temperature		T_S	150	$^\circ\text{C}$
UL1577				
Insulation voltage per UL	$V_{TEST} = V_{ISO}, t = 60\text{ s (qualification)}$, $V_{TEST} = 1.2 \times V_{ISO}, t = 1\text{ s (100% production test)}$	V_{ISO}	5700	V_{RMS}

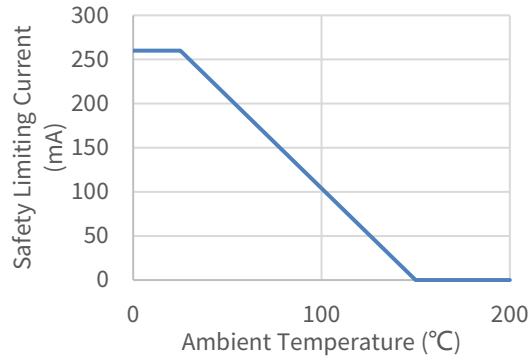

Figure 6.1 NSI1311 Thermal Derating Curve, Dependence of Safety Limiting Values with Case Temperature per VDE0884-17

6.3. Regulatory Information

The NSI1311 are approved or pending approval by the organizations listed in table.

UL		VDE	CQC	TUV
UL 1577 Component Recognition Program	Approved under CSA Component Acceptance Notice 5A	DIN EN IEC 60747-17 (VDE 0884-17)	Certified according to GB4943.1	Certified According to EN IEC 62368-1
Single Protection, 5700V _{rms} Isolation voltage	Single Protection, 5700V _{rms} Isolation voltage	Reinforce Insulation $V_{IORM}=2121V_{peak}$ $V_{IOTM}=8000V_{peak}$ $V_{IOSM}=10000V_{peak}$	Reinforced insulation	5000Vrms for 1min
E500602	E500602	40052820	CQC20001264938	R50574061

7. Function Description

7.1. Overview

The NSI1311 is a high performance isolated amplifier with a high input impedance that accept wide range single-ended input. The singled-ended input is suited to bus voltage monitoring in high voltage applications where isolation is required.

The analog input is continuously sampled by a second-order Σ - Δ modulator in the device. With the internal voltage reference and clock generator, the modulator converts the analog input signal to a digital bitstream. The output of the modulator is transferred by the drivers (called TX in the Functional Block Diagram) across the isolation barrier that separates the isolated side1 and side2 voltage. The received bitstream and clock are synchronized and processed, as shown in the Functional Block Diagram, by a fourth-order analog filter on the side2 and has a differential output.

SHTDN pin is used to disable the conversion. Since SHTDN is an active high signal and is pulled up by a 100k Ω (typical) internally, it should be connected to GND1 or logic LOW in normal operation.

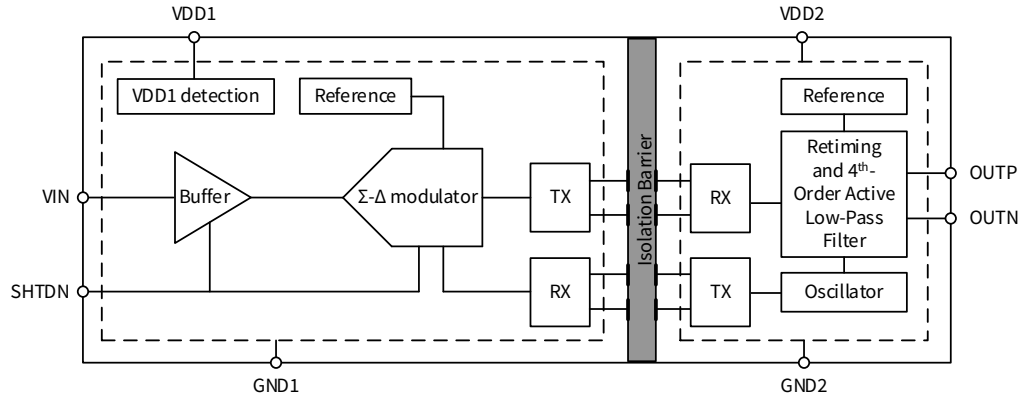

Figure 7.1 Function Block Diagram

7.2. Analog Input

There are two restrictions on the analog input signal (V_{IN}).

- If the input voltage exceeds the range $GND1 - 6\text{ V}$ to $VDD1 + 0.5\text{ V}$, the input current must be limited to 10 mA because the device input electrostatic discharge (ESD) diodes turn on.
- The linearity and noise performance of the device are ensured only when the analog input voltage remains within the specified linear full-scale range (FSR).

7.3. Analog Output

For linear input range, NSI1311 provides an analog differential output which has a fixed gain of 1. If a full-scale input signal is applied to the NSI1311 ($V_{IN} \geq V_{Clipping}$), the analog output will be clipped, as is shown in Figure 7.2(a).

In addition, NSI1311 integrates some diagnostic measures and offers a fail-safe output to simplify system-level design. The fail-safe output is a negative differential output voltage shown in Figure 7.2(b), which does not occur under normal device operation and will only be activated in following conditions:

- When the undervoltage of VDD1 is detected ($VDD1 < VDD1_{UV}$).
- When SHTDN signal is activated (pulled high).

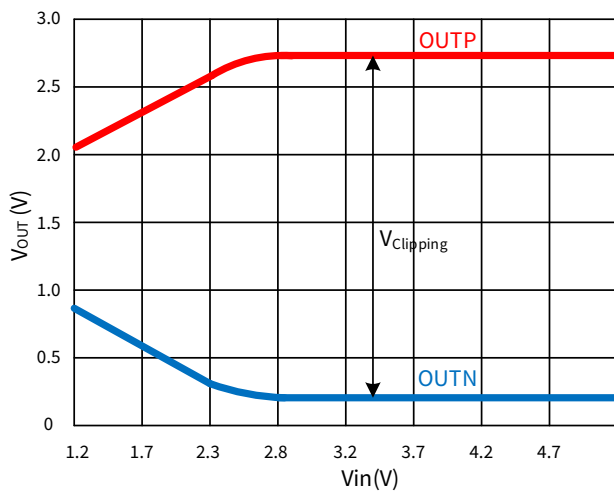

(a)

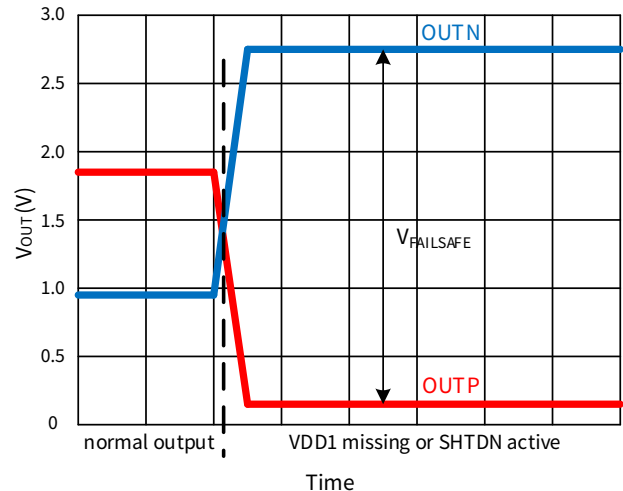

(b)

Figure 7.2 Typical Failsafe output and clipping output

8. Application Note

8.1. Typical Application Circuit

NSI1311 has an input impedance of up to 1G Ω , and has a wide input voltage range as well. These features make NSI1311 ideally suitable for isolated voltage sensing applications such as frequency inverters. The typical application circuit is shown in Figure 8.1.

The bus voltage of the frequency inverter is divided by a resistance network, and the divided voltage is applied to the input of NSI1311 through a RC filter. The differential output of the isolated amplifier is converted to a single-ended analog output with an operational-amplifier-based circuit. An analog-to-digital converter usually receives the analog output and converts to digital signal for controller processing.

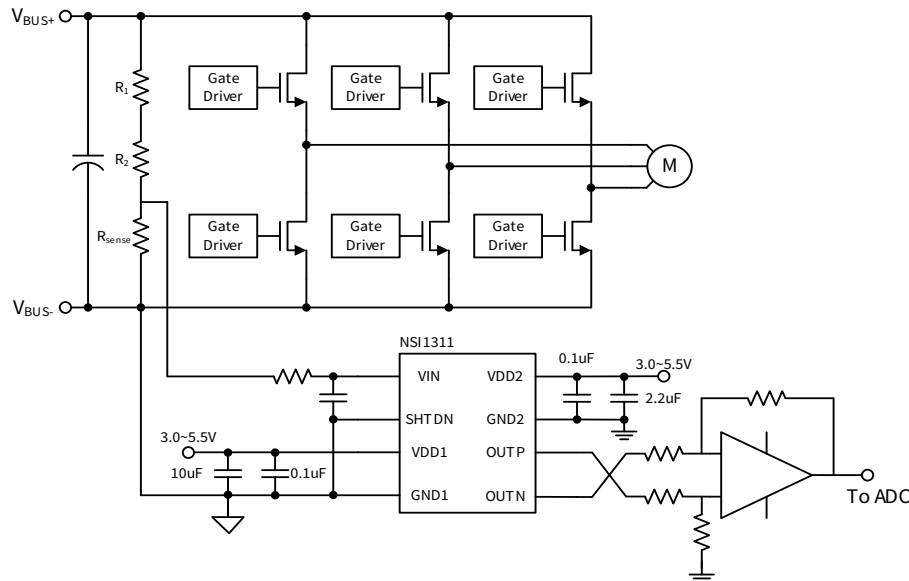

Figure 8.1 Typical application circuit in voltage sensing

8.2. Sense Resistor Selection

There are two other factors should be considered when selecting the sense resistor:

- The voltage-drop on R_{sense} divided by nominal V_{BUS} must not exceed the recommended linear input voltage range: $V_{IN} \leq FSR$.
- The voltage-drop on R_{sense} divided by V_{BUS} in maximum allowed overvoltage condition must not exceed the input voltage that causes a clipping output: $V_{IN} \leq V_{Clipping}$.

8.3. PCB Layout

- NSI1311 requires a 0.1 μ F bypass capacitor between VDD1 and GND1, VDD2 and GND2. The capacitor should be placed as close as possible to the VDD pin. If better filtering is required, an additional 1~10 μ F capacitor may be used.

9. Package Information

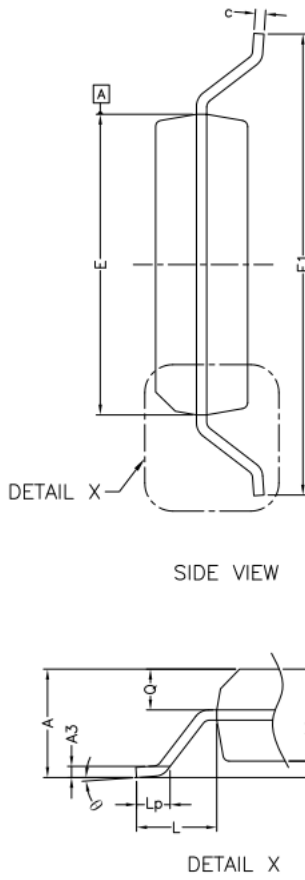
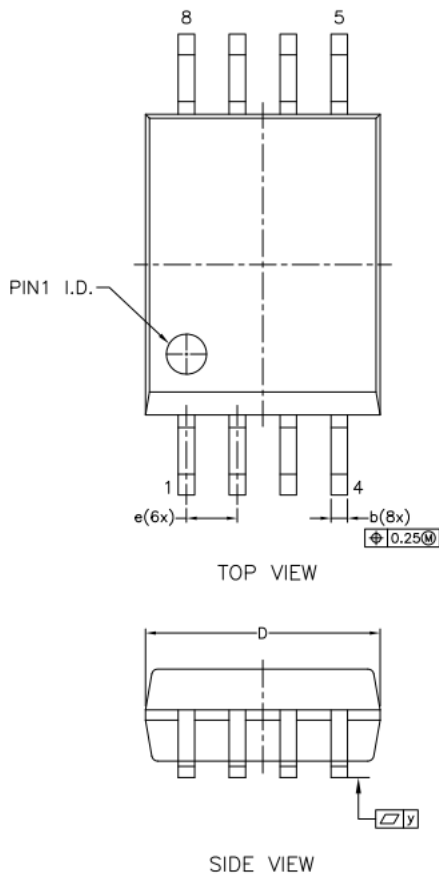

* CONTROLLING DIMENSION : MM

SYMBOL	MM		
	MIN.	NOM.	MAX.
A	--	--	2.80
A1	0.36	--	0.46
A2	2.20	2.30	2.40
A3	--	0.25	--
Q	0.97	1.02	1.07
b	0.31	0.41	0.51
c	0.13	--	0.33
D	5.75	5.85	5.95
E	7.40	7.50	7.60
E1	11.25	11.50	11.75
e	1.27 bsc		
L	2.00 bsc		
Lp	0.50	--	1.00
y	--	0.10	--
θ	0°	--	8°

Figure 9.1 SOW8 Package Shape and Dimension in millimeters

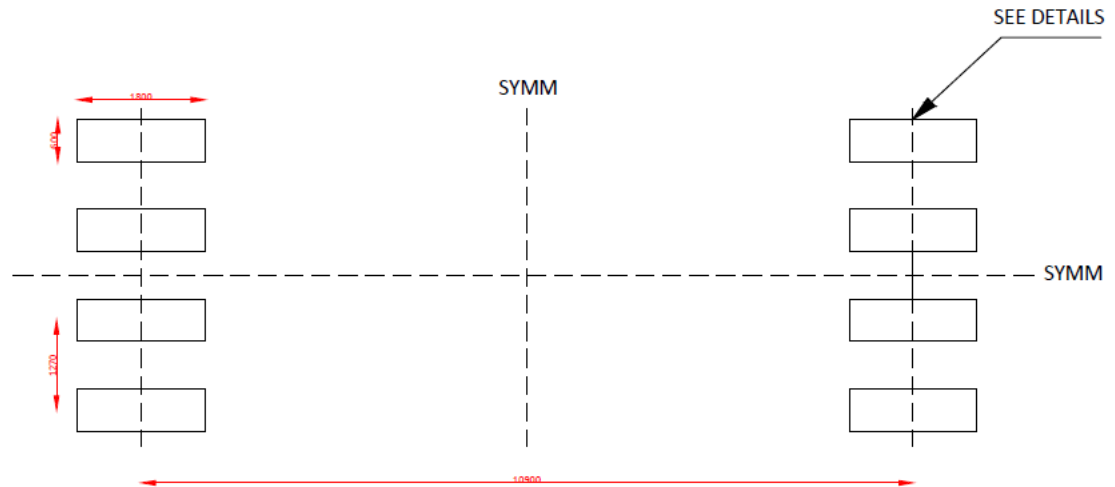

LAND PATTERN EXAMPLE(um)

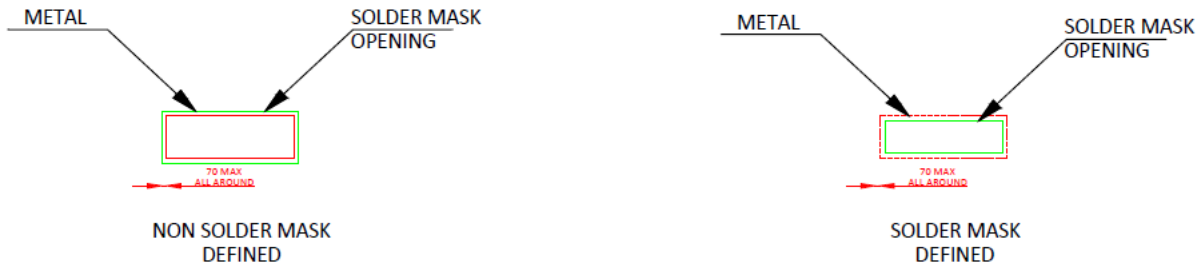

Figure 9.2 SOW8 Package Board Layout Example

10. Ordering Information

Part No.	Isolation Rating(kV)	Linear Input Range(V)	Moisture Sensitivity Level	Temperature	Automotive	Package Type	Package Drawing	SPQ
NSI1311-Q1SWVR	5	0.02 ~ 2	Level-3	-40 to 125°C	YES	SOP8 (300mil)	SOW8	1000

11. Documentation Support

Part Number	Product Folder	Datasheet	Technical Documents	Isolator selection guide
NSI1311	Click here	Click here	Click here	Click here

12. Tape and Reel Information

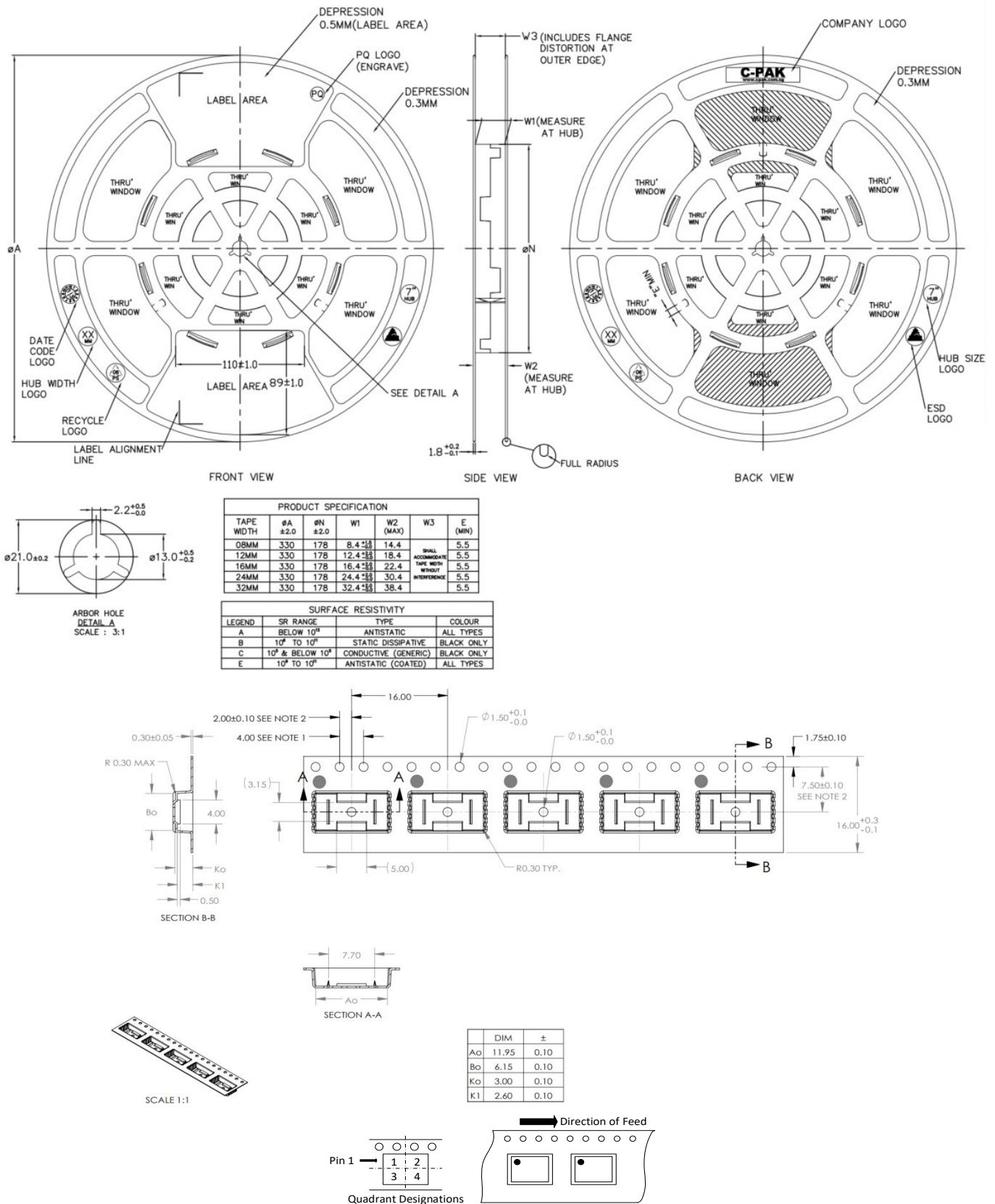

Figure 12.1 Tape and Reel Information of SOP8(300mil)

13. Revision History

Revision	Description	Date
1.0	Initial Release	2021/6/23
1.1	Add SOW8 board layout example and update insulation characteristics	2021/7/17
1.2	Add Tj in absolute maximum ratings and update DTI in 6.1	2022/4/13
1.3	Update V_{FSR} specification in Part 3, Nonlinearity specification in 5.1, the standard on which V_{IOSM} test method is based in 6.2, description form of Vpd (m) in 6.2, Figure 7.2 and its description in 7.3, and important notice at the end of the datasheet. Update typeface to Source Sans Pro.	2023/02/21
1.4	Update IDD1 specification when SHTDN=HIGH in Part 5.1; Update all NSi to NSI. Update test temperature condition of Vos, I_{IB} , E_G and Nonlinearity Update safety regulatory info	2024/11/27

IMPORTANT NOTICE

The information given in this document shall in no event be regarded as any warranty or authorization of, express or implied, including but not limited to accuracy, completeness, merchantability, fitness for a particular purpose or infringement of any third party's intellectual property rights.

You are solely responsible for your use of Novosense' products and applications, and for the safety thereof. You shall comply with all laws, regulations and requirements related to Novosense's products and applications, although information or support related to any application may still be provided by Novosense.

The resources are intended only for skilled developers designing with Novosense' products. Novosense reserves the rights to make corrections, modifications, enhancements, improvements or other changes to the products and services provided. Novosense authorizes you to use these resources exclusively for the development of relevant applications designed to integrate Novosense's products. Using these resources for any other purpose, or any unauthorized reproduction or display of these resources is strictly prohibited. Novosense shall not be liable for any claims, damages, costs, losses or liabilities arising out of the use of these resources.

For further information on applications, products and technologies, please contact Novosense (www.novosns.com).

Suzhou Novosense Microelectronics Co., Ltd