

## Product Overview

The NCA1042C is a high-speed CAN transceiver that provides an interface between a Controller Area Network (CAN) protocol controller and the physical two-wire CAN bus. The NCA1042C implements the CAN physical layer as defined in ISO 11898-2-2024 and SAE J2284-1 to SAE J2284-5. This implementation enables reliable communication in the CAN FD fast phase at data rates up to 5 Mbit/s. The NCA1042C provides thermal protection and transmit data dominant time out function.

## Key Features

- Fully compatible with the ISO11898-2 standard
- Ideal passive behavior to the CAN bus when the supply voltage is off
- I/O voltage range supports 1.8V, 3.3V and 5V MCU
- Power supply voltage
- V<sub>IO</sub>: 1.7V to 5.5V
- V<sub>CC</sub>: 4.5V to 5.5V
- Bus fault protection of -70V to +70V
- Short circuit protection
- Bus common-mode voltage of -12V to +12V
- Transmit data (TXD) dominant time out function
- Very low-current Standby mode with wake-up capability
- Over temperature protection
- Improve the bus signal by ringing reduction
- Data rate: up to 5Mbps
- Low loop delay: <250ns
- Operation temperature: -40°C to +125°C
- RoHS & REACH compliant

## Applications

- CAN bus standards such as CANopen, DeviceNet, NMEA2000, ARNIC825, ISO11783 and CANaerospace
- Highly loaded CAN networks down to 10 kbps networks
- Industrial automation, control, sensors, and drive systems
- Building, security, and climate control automation

## Device Information

Part Number	Package	Body Size
NCA1042C-DSPR	SOP8	4.90mm × 3.90mm
NCA1042CN-DSPR	SOP8	4.90mm × 3.90mm
NCA1042C-DSPRH	SOP8	4.90mm × 3.90mm
NCA1042CN-DSPRH	SOP8	4.90mm × 3.90mm

## Functional Block Diagrams

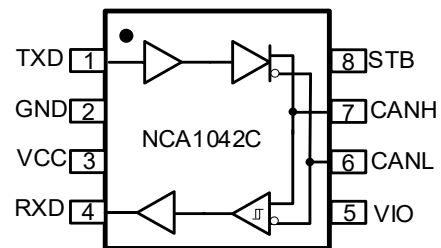

Figure 1. NCA1042C Block Diagram

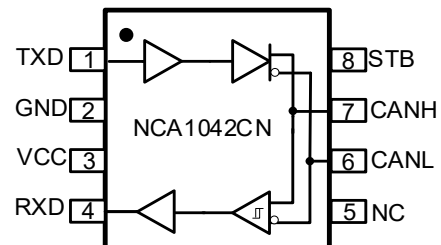

Figure 2. NCA1042CN Block Diagram

## INDEX

<b>1. PIN CONFIGURATION AND FUNCTIONS</b> .....	<b>3</b>
<b>2. ABSOLUTE MAXIMUM RATINGS</b> .....	<b>4</b>
<b>3. EMC RATINGS</b> .....	<b>4</b>
<b>4. RECOMMENDED OPERATING CONDITIONS</b> .....	<b>5</b>
<b>5. THERMAL INFORMATION</b> .....	<b>5</b>
<b>6. SPECIFICATIONS</b> .....	<b>6</b>
<b>6.1. ELECTRICAL CHARACTERISTICS</b> .....	<b>6</b>
<b>6.2. SWITCHING ELECTRICAL CHARACTERISTICS</b> .....	<b>9</b>
<b>6.3. PARAMETER MEASUREMENT INFORMATION</b> .....	<b>11</b>
<b>7. FUNCTION DESCRIPTION</b> .....	<b>13</b>
<b>7.1. OVERVIEW</b> .....	<b>13</b>
<b>7.2. FUNCTIONAL BLOCK DIAGRAM</b> .....	<b>13</b>
<b>7.3. SIGNAL RINGING REDUCTION</b> .....	<b>14</b>
<b>7.4. VIO SUPPLY PIN</b> .....	<b>14</b>
<b>7.5. DEVICE FUNCTIONAL MODES</b> .....	<b>14</b>
7.5.1. Normal Mode .....	14
7.5.2. Standby Mode .....	14
<b>7.6. REMOTE WAKE-UP</b> .....	<b>14</b>
<b>7.7. FAIL-SAFE FEATURES</b> .....	<b>16</b>
7.7.1. TXD Dominant Time-Out Function (TXD DTO).....	16
7.7.2. Internal Biasing of TXD and STB Input Pins .....	16
7.7.3. Undervoltage Detection on Pins VCC and VIO.....	16
7.7.4. Unpowered Device .....	16
7.7.5. Over-Temperature Protection (OTP).....	16
7.7.6. Short Circuit Protection.....	17
<b>8. APPLICATION NOTE</b> .....	<b>18</b>
<b>8.1. TYPICAL APPLICATION</b> .....	<b>18</b>
<b>9. PACKAGE INFORMATION</b> .....	<b>19</b>
<b>10. ORDERING INFORMATION</b> .....	<b>20</b>
<b>11. DOCUMENTATION SUPPORT</b> .....	<b>20</b>
<b>12. TAPE AND REEL INFORMATION</b> .....	<b>21</b>
<b>13. REVISION HISTORY</b> .....	<b>22</b>

# 1. Pin Configuration and Functions

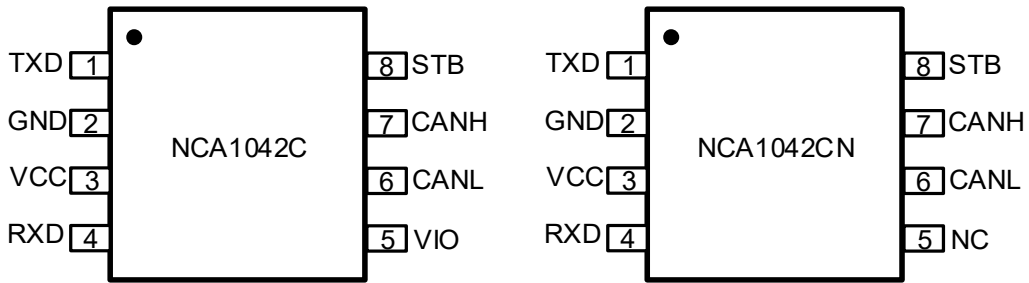

Figure 1-1 NCA1042C, NCA1042CN Package

Table 1-1 NCA1042C Pin Configuration and Description

<b>NCA1042C PIN NO.</b>	<b>NCA1042CN PIN NO.</b>	<b>SYMBOL</b>	<b>FUNCTION</b>
1	1	TXD	CAN transmit data input (LOW for dominant and HIGH for recessive bus states)
2	2	GND	Ground
3	3	VCC	Power Supply
4	4	RXD	CAN receive data output (LOW for dominant and HIGH for recessive bus states)
5	\	VIO	Logic I/O supply voltage
\	5	NC	No connection
6	6	CANL	Low-level CAN bus line
7	7	CANH	High-level CAN bus line
8	8	STB	STB (standby mode) select pin (active high)

## 2. Absolute Maximum Ratings

Over operating free-air temperature range (unless otherwise noted)<sup>[1][2]</sup>.

Parameters	Symbol	Min	Max	Unit
Power Supply Voltage	VCC, VIO	-0.3	7	V
Logic I/O Voltage	TXD, RXD, STB	-0.3	7	V
Maximum bus Pin Voltage	V <sub>CANH</sub> , V <sub>CANL</sub>	-70	70	V
Voltage between pin CANH and pin CANL	V <sub>CANH</sub> - V <sub>CANL</sub>	-70	70	V
Junction temperature	T <sub>J</sub>	-40	150	°C
Storage Temperature	T <sub>stg</sub>	-65	150	°C

<sup>[1]</sup> Stresses beyond those listed under Absolute Maximum Ratings may cause permanent damage to the device. Exposure to Absolute Maximum Rating condition for extended periods may affect device reliability.

<sup>[2]</sup> All voltage values, except for “Voltage between pin CANH and pin CANL”, are with respect to GND terminal.

## 3. EMC Ratings

Parameters	Ratings	Value	Unit	
Electrostatic discharge	Human Body Model (HBM), per ANSI/ ESDA/ JEDEC JS-001	±8	kV	Not H Version
	<ul style="list-style-type: none"> <li>CANH and CANL, to GND</li> <li>Other pins, to GND</li> </ul>	±8	kV	
	Human Body Model (HBM), per ANSI/ ESDA/ JEDEC JS-001	±6	kV	H Version
	<ul style="list-style-type: none"> <li>CANH and CANL, to GND</li> <li>Other pins, to GND</li> </ul>	±6	kV	
	Machine Model (MM), per JESD22-A115C	±400	V	
System, per IEC 61000 4 2 (150 pF, 330 Ω at pins CANH and CANL to GND)	±8.0	kV	Not H Version	
System, per IEC 61000 4 2 (150 pF, 330 Ω at pins CANH and CANL to GND)	±3.0	kV	H Version	
Electrical disturbances	Electrical transient conduction, per ISO 7637-2, on CANH and CANL	-100	V	
	<ul style="list-style-type: none"> <li>Pulse 1</li> <li>Pulse 2a</li> <li>Pulse 3a</li> <li>Pulse 3b</li> </ul>	75	V	
		-150	V	
		100	V	

## 4. Recommended Operating Conditions

<i>Parameters</i>	<i>Symbol</i>	<i>Min</i>	<i>Typ</i>	<i>Max</i>	<i>Unit</i>
Power Supply Voltage	VCC	4.5	5	5.5	V
I/O Level-Shifting Voltage	VIO	1.7	3.3	5.5	V
Operating Temperature	T <sub>opr</sub>	-40	-	125	°C

## 5. Thermal Information

<i>Parameters</i>	<i>Symbol</i>	<i>SOP8</i>	<i>Unit</i>
IC Junction-to-Air Thermal Resistance	R <sub>θJA</sub>	120	°C /W
Junction-to-case (top) thermal resistance	R <sub>θJC(top)</sub>	57.8	°C /W
Junction-to-board thermal resistance	R <sub>θJB</sub>	64.2	°C /W

## 6. Specifications

### 6.1. Electrical Characteristics

$V_{CC}=4.5V$  to  $5.5V$ ,  $V_{IO}=1.7$  to  $5.5V$  [1],  $T_a=-40^{\circ}C$  to  $125^{\circ}C$ . Unless otherwise noted, Typical values are at  $V_{CC}=5V$ ,  $V_{IO}=3.3V$ ,  $R_L=60\Omega$ ,  $T_a = 25^{\circ}C$ .

Symbol	Parameters	Conditions	Min	Typ	Max	Unit
<b>Supply; pin VCC</b>						
$V_{CC}$	Supply voltage		4.5	-	5.5	V
$I_{CC}$	Supply current	Normal mode, recessive, $V_{TXD}=V_{IO}$ [2], $V_{STB}=0V$	-	5	7	mA
		Normal mode, dominant, $V_{TXD}=0V$	-	45	60	mA
		Normal mode, dominant, $V_{TXD}=0$ , short circuit on bus lines, $-3V < (V_{CANH} = V_{CANL}) < 18V$	-	-	110	mA
		Standby mode, $V_{TXD}=V_{IO}$ , NCA1042C	-	0.7	2	$\mu A$
		Standby mode, $V_{TXD}=V_{CC}$ , NCA1042CN	-	13.5	20	$\mu A$
$V_{LVD(VCC)}$	Undervoltage detection voltage on pin VCC	Rising	4	4.26	4.5	V
		Falling	4	4.17	4.5	V
<b>I/O level adapter supply; pin VIO; only for NCA1042C</b>						
$V_{IO}$	Supply voltage on pin VIO		1.7	-	5.5	V
$I_{IO}$	Supply current on pin VIO	Normal mode, recessive, $V_{TXD}=V_{IO}$	-	60	200	$\mu A$
		Normal mode, dominant, $V_{TXD}=0V$	-	175	360	$\mu A$
		Standby mode; $V_{TXD}=V_{IO}$	-	11	19	$\mu A$
$V_{LVD(VIO)}$	Undervoltage detection voltage on pin VIO	Rising	1.4	1.56	1.7	V
		Falling	1.4	1.50	1.7	V
<b>Standby mode control input; pin STB</b>						
$V_{IH}$	High level input voltage		$0.7 \cdot V_{IO}$ [2]	-	$V_{IO} + 0.3$ [2]	V
$V_{IL}$	Low level input voltage		-0.3	-	$0.3 \cdot V_{IO}$ [2]	V
$R_{pu}$	Pull-up resistance		40	55	80	k $\Omega$
<b>CAN transmit data input; pin TXD</b>						
$V_{IH}$	High level input voltage		$0.7 \cdot V_{IO}$ [2]	-	$V_{IO} + 0.3$ [2]	V

Symbol	Parameters	Conditions	Min	Typ	Max	Unit
V <sub>IL</sub>	Low level input voltage		-0.3	-	$0.3 \cdot V_{IO}^{[2]}$	V
R <sub>pu</sub>	Pull-up resistance		40	55	80	kΩ
C <sub>i</sub>	Input capacitance	[3]	-	5	10	pF
<b>CAN receive data output; pin RXD</b>						
I <sub>OH</sub>	High level output current	V <sub>RXD</sub> = V <sub>IO</sub> - 0.4V [2]	-10	-3	-1	mA
I <sub>OL</sub>	Low level output current	V <sub>RXD</sub> = 0.4V; bus dominant	1	3.5	10	mA
<b>Bus lines; pins CANH and CANL; Driver</b>						
V <sub>OH(D)</sub>	CANH output voltage (Dominant)	V <sub>TXD</sub> = 0V, R <sub>L</sub> = 50Ω to 65Ω <sup>[4]</sup>	2.75	3.6	4.5	V
V <sub>OL(D)</sub>	CANL output voltage (Dominant)	V <sub>TXD</sub> = 0V, R <sub>L</sub> = 50Ω to 65Ω <sup>[4]</sup>	0.5	1.4	2.25	V
V <sub>OH(R)</sub>	CANH output voltage (Recessive)	Normal mode, no load <sup>[4]</sup>	2.0	0.5*V <sub>CC</sub>	3.0	V
		Standby mode, no load <sup>[4]</sup>	-0.1	-	0.1	V
V <sub>OL(R)</sub>	CANL output voltage (Recessive)	Normal mode, no load <sup>[4]</sup>	2.0	0.5*V <sub>CC</sub>	3.0	V
		Standby mode, no load <sup>[4]</sup>	-0.1	-	0.1	V
V <sub>OD(D)</sub>	Differential output voltage (Dominant)	Normal mode				
		R <sub>L</sub> = 50Ω to 65Ω <sup>[4]</sup>	1.5	-	3.0	V
		R <sub>L</sub> = 45Ω to 70Ω <sup>[4]</sup>	1.4	-	3.3	V
		R <sub>L</sub> = 2240Ω <sup>[4]</sup>	1.5	-	5.0	V
V <sub>OD(R)</sub>	Differential output voltage (Recessive)	Normal mode, no load <sup>[4]</sup>	-50	-	50	mV
		Standby mode, no Load <sup>[4]</sup>	-0.2	-	0.2	V
V <sub>TXsym</sub>	Transmitter voltage symmetry	V <sub>TXsym</sub> = V <sub>CANH</sub> + V <sub>CANL</sub> , [3] f <sub>TXD</sub> = 1MHz, R <sub>L</sub> = 60Ω, C <sub>SPLIT</sub> = 4.7nF, V <sub>CC</sub> = 4.75V to 5.25V <sup>[4]</sup> [5]	0.9*V <sub>CC</sub>	-	1.1*V <sub>CC</sub>	V
I <sub>OSH(R)</sub>	CANH short-circuit output current, recessive	Normal mode, V <sub>CANH</sub> = V <sub>CANL</sub> = -27V to 32V	-2	-	2	mA
I <sub>OSL(R)</sub>	CANL short-circuit output current, recessive	Normal mode, V <sub>CANH</sub> = V <sub>CANL</sub> = -27V to 32V	-2	-	2	mA
I <sub>OSH(D)</sub>	CANH short-circuit output current, dominant	Normal mode, V <sub>CANH</sub> = -15V to 40V, CANL open <sup>[4]</sup>	-100	-	100	mA

Symbol	Parameters	Conditions	Min	Typ	Max	Unit
I <sub>OSL(D)</sub>	CANL short-circuit output current, dominant	Normal mode, V <sub>CANL</sub> = -15V to 40V, CANH open <sup>[4]</sup>	-100	-	100	mA
<b>Bus lines; pins CANH and CANL; Receiver</b>						
V <sub>ID(R)</sub>	Differential input threshold voltage, recessive	-12V < V <sub>CANH</sub> < 12V, -12V < V <sub>CANL</sub> < 12V				
		Normal mode <sup>[4]</sup>	0.5	-	0.9	V
		Standby mode <sup>[4]</sup>	0.4	-	1.15	V
V <sub>ID(D)</sub>	Differential input threshold voltage, dominant	-12V < V <sub>CANH</sub> < 12V, -12V < V <sub>CANL</sub> < 12V				
		Normal mode <sup>[4]</sup>	0.5	-	0.9	V
		Standby mode <sup>[4]</sup>	0.4	-	1.15	V
V <sub>hys</sub>	Differential input hysteresis voltage	-12V < V <sub>CANH</sub> < 12V, -12V < V <sub>CANL</sub> < 12V, Normal mode	-	50	100	mV
V <sub>RX(R)</sub>	Receiver recessive voltage	-12V < V <sub>CANH</sub> < 12V, -12V < V <sub>CANL</sub> < 12V				
		Normal mode <sup>[3]</sup>	-4	-	0.5	V
		Standby mode <sup>[3]</sup>	-4	-	0.4	V
V <sub>RX(D)</sub>	Receiver dominant voltage	-12V < V <sub>CANH</sub> < 12V, -12V < V <sub>CANL</sub> < 12V				
		Normal mode <sup>[3]</sup>	0.9	-	9	V
		Standby mode <sup>[3]</sup>	1.15	-	9	V
I <sub>LKG(OFF)</sub>	Power-off (unpowered) bus input leakage current	V <sub>CANH</sub> = V <sub>CANL</sub> = 5V, V <sub>CC</sub> = V <sub>IO</sub> = 0V <sup>[4]</sup>	-10	-	10	μA
R <sub>i</sub>	Input resistance	-2V ≤ V <sub>CANH</sub> ≤ 7V, -2V ≤ V <sub>CANL</sub> ≤ 7V <sup>[4]</sup>	25	40	50	kΩ
R <sub>I(match)</sub>	Input resistance matching	V <sub>CANH</sub> = 5V, V <sub>CANL</sub> = 5V, R <sub>I(match)</sub> = 2 * (R <sub>CANH</sub> - R <sub>CANL</sub> ) / (R <sub>CANH</sub> + R <sub>CANL</sub> )	-3	-	3	%
R <sub>ID</sub>	Differential input resistance	-2V ≤ V <sub>CANH</sub> ≤ 7V, -2V ≤ V <sub>CANL</sub> ≤ 7V, R <sub>ID</sub> = R <sub>CANH</sub> + R <sub>CANL</sub> <sup>[4]</sup>	50	80	100	kΩ
C <sub>i</sub>	Input capacitance to ground	CANH or CANL <sup>[3]</sup>	-	-	30	pF
C <sub>ID</sub>	Differential input	<sup>[3]</sup>	-	-	15	pF
<b>Temperature detection</b>						
T <sub>SD</sub>	Thermal shutdown threshold	<sup>[3]</sup>	-	193	-	°C

Symbol	Parameters	Conditions	Min	Typ	Max	Unit
$T_{SD(hys)}$	Thermal shutdown hysteresis	[3]	-	11	-	°C

[1] Only NCA1042C has a VIO pin. For NCA1042CN, the VIO input is internally connected to VCC.

[2]  $V_{IO}=V_{CC}$  for the version without VIO pin.

[3] Not tested in production; guaranteed by design.

[4] Required in ISO 11898-2-2024.

[5] The test circuit used to measure the bus output voltage symmetry (which includes  $C_{SPLIT}$ ) is shown in Figure 6-3.

## 6.2. Switching Electrical Characteristics

$V_{CC}=4.5V\sim 5.5V$ ,  $V_{IO}=1.7\sim 5.5V$ <sup>[1]</sup>,  $T_a=-40^{\circ}C$  to  $125^{\circ}C$ . Unless otherwise noted, Typical values are at  $V_{CC}=5V$ ,  $V_{IO}=3.3V$ ,  $R_L=60\Omega$ ,  $T_a=25^{\circ}C$ .

Symbol	Parameters	Comments	Min	Typ	Max	Unit
<b>Driver</b>						
$t_{d(TXD-bus, dom)}$	Delay time from TXD to bus dominant	Normal mode <sup>[3]</sup>	-	40	-	ns
$t_{d(TXD-bus, rec)}$	Delay time from TXD to bus recessive	Normal mode <sup>[3]</sup>	-	65	-	ns
$t_{bit(bus)}$	Transmitted recessive bit width	$t_{bit(TXD)} = 500$ ns	435	495	530	ns
		$t_{bit(TXD)} = 200$ ns	155	195	210	ns
<b>Receiver</b>						
$t_{d(bus-RXD, dom)}$	Delay time from bus to RXD dominant	[3]	-	90	-	ns
$t_{d(bus-RXD, rec)}$	Delay time from bus to RXD recessive	[3]	-	80	-	ns
$t_{d(TXD-RXD, dom)}$	Delay time from TXD to RXD dominant	Normal mode <sup>[3]</sup>	-	130	230	ns
$t_{d(TXD-RXD, rec)}$	Delay time from TXD to RXD recessive	Normal mode <sup>[3]</sup>	-	145	230	ns
$t_{bit(RXD)}$	Bit time on pin RXD	$t_{bit(TXD)} = 500$ ns	400	-	550	ns
		$t_{bit(TXD)} = 200$ ns	120	-	220	ns
<b>CAN FD timing characteristics</b>						
$\Delta t_{rec}$	Receiver timing symmetry	$\Delta t_{rec} = t_{bit(RXD)} - t_{bit(bus)}$ <sup>[3]</sup>				
		$t_{bit(TXD)} = 500$ ns	-65	-	40	ns
		$t_{bit(TXD)} = 200$ ns	-45	-	15	ns
<b>Dominant time-out time; pin TXD</b>						
$t_{to(dom)TXD}$	TXD dominant time-out time	Normal mode <sup>[3]</sup>	0.8	2.8	5	ms
<b>Bus wake-up time; pins CANH, CANL</b>						

<b>Symbol</b>	<b>Parameters</b>	<b>Comments</b>	<b>Min</b>	<b>Typ</b>	<b>Max</b>	<b>Unit</b>
$t_{\text{wake(bus, dom)}}$	Bus dominant wake-up time	Standby mode <sup>[3]</sup>	0.5	-	1.8	$\mu\text{s}$
$t_{\text{wake(bus, rec)}}$	Bus recessive wake-up time	Standby mode <sup>[3]</sup>	0.5	-	1.8	$\mu\text{s}$
$t_{\text{to(wake)bus}}$	Bus wake-up time out	Standby mode <sup>[3]</sup>	0.8	-	9	ms
$t_{\text{fltr(wake)bus}}$	Bus wake-up filter time	Standby mode <sup>[3]</sup>	-	-	1.8	$\mu\text{s}$
<b>Mode transition</b>						
$t_{\text{d(stb-norm)}}$	Standby to normal mode delay time	<sup>[2]</sup>	-	-	47	$\mu\text{s}$
$t_{\text{startup(RXD)}}$	RXD start-up time	After wake-up detected <sup>[2]</sup>	-	-	50	$\mu\text{s}$

<sup>[1]</sup> Only NCA1042C has a VIO pin. For NCA1042CN, the VIO input is internally connected to VCC.

<sup>[2]</sup> Not tested in production; guaranteed by design.

<sup>[3]</sup> Required in ISO 11898-2-2024.

6.3. Parameter Measurement Information

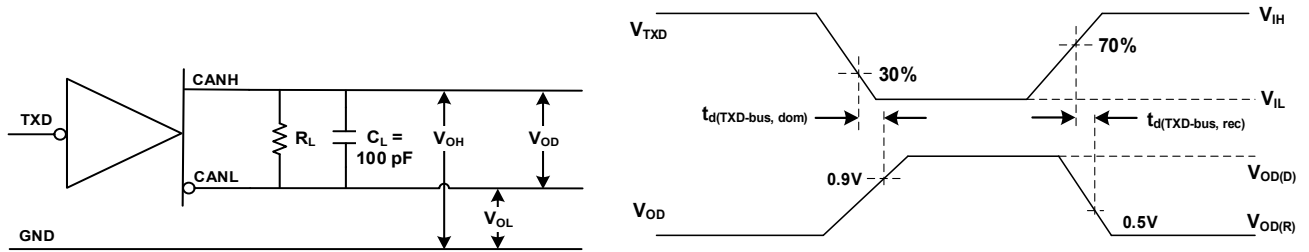

Figure 6-1 Driver Test Circuit and Voltage Waveforms<sup>[1]</sup>

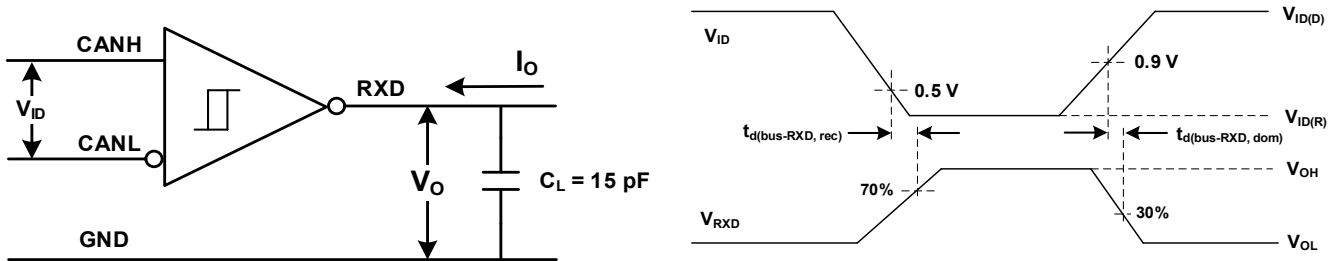

Figure 6-2 Receiver Test Circuit and Voltage Waveforms

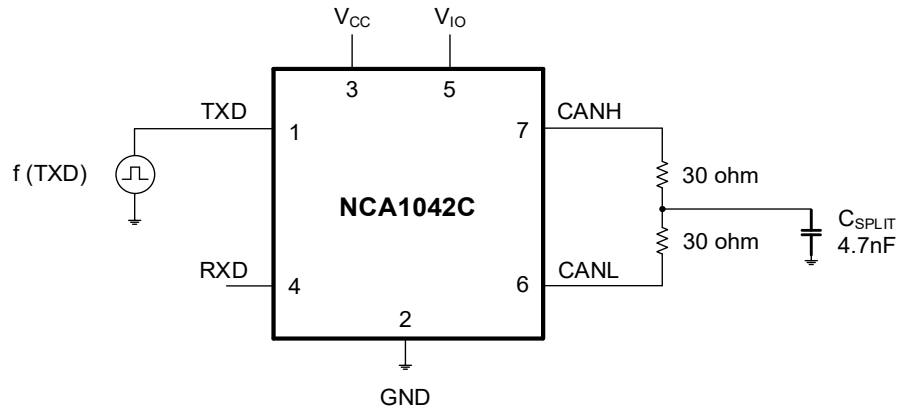

Figure 6-3 Transceiver Driver Symmetry Test Circuit

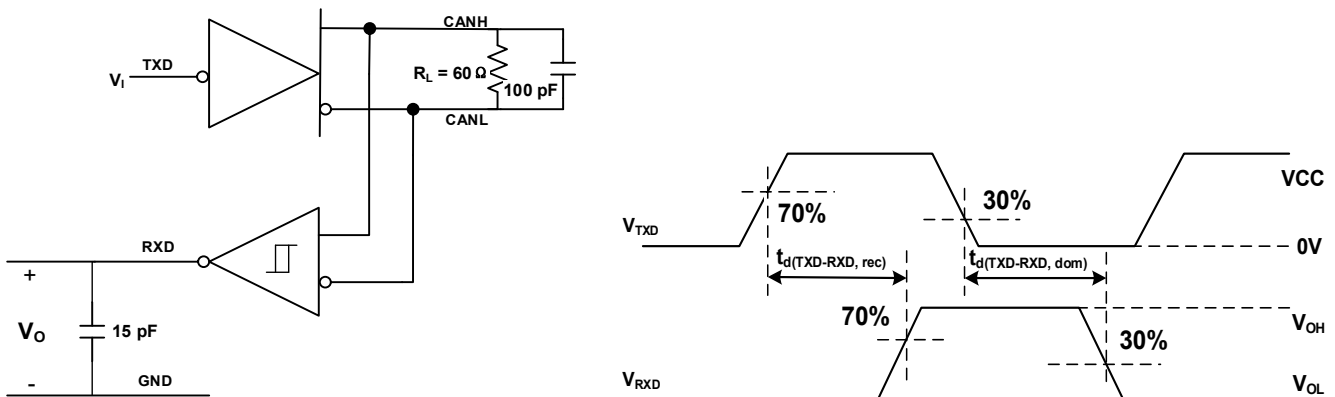

Figure 6-4 Loop Time Test Circuit and Voltage Waveforms<sup>[1]</sup>

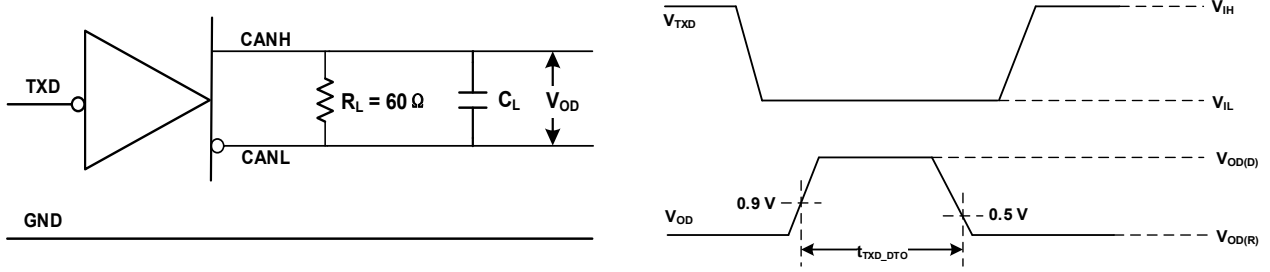

Figure 6-5 TXD Dominant Time-out Test Circuit and Voltage Waveforms

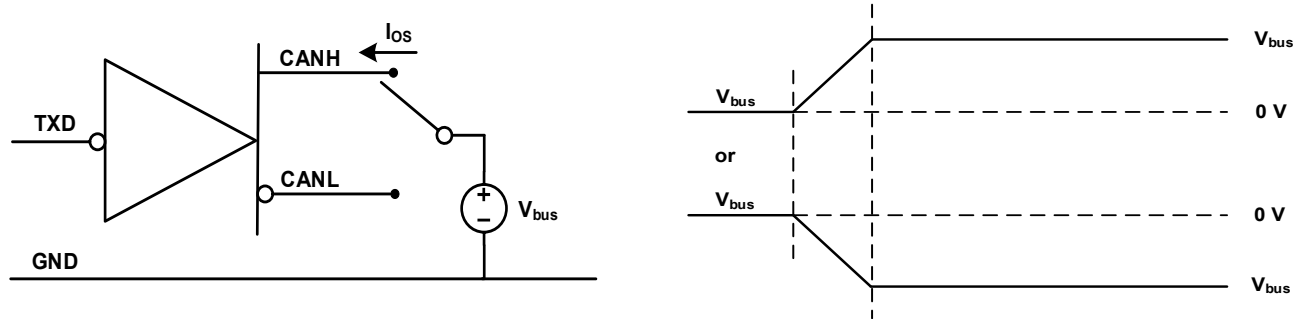

Figure 6-6 Driver Short-Circuit Current Test Circuit and Waveforms

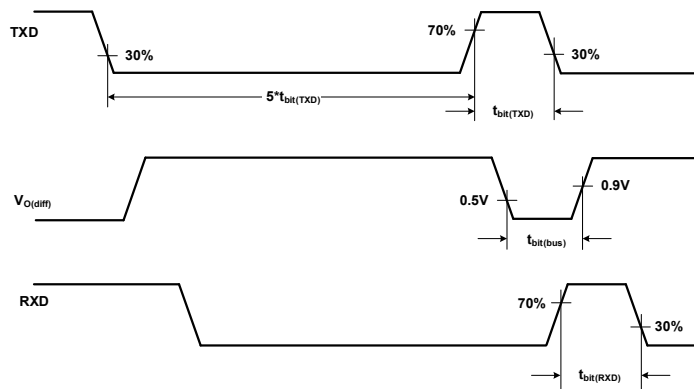

Figure 6-7  $t_{bit(RXD)}$  Test Circuit and Waveforms<sup>[1]</sup>

<sup>[1]</sup> For NCA1042CN-Q1, TXD high level is set as 2.0V instead; TXD low level, 0.8V instead.

## 7. Function Description

### 7.1. Overview

The NCA1042C is a CAN transceiver which fully compatible with the ISO11898-2 standard. The data rate of the NCA1042C is up to 5Mbps, and it can support up to 110 CAN nodes. Meanwhile, the maximum transmission rate of the CAN bus is limited by the bus load, the quantity of nodes, the cable length, and other factors. The NCA1042C has a  $\pm 12V$  input common-mode range, enabling reliable communication between bus nodes with large ground potential deviations. NCA1042C has a low-current standby mode with CAN BUS waked-up capability.

Comprehensive protection features are designed to enhance the device and network robustness in harsh operating conditions. The transmit data dominant time-out function prevents the bus from lock-up by the faults on micro-controller. Moreover, the NCA1042C provides thermal protection and short-circuit protection.

### 7.2. Functional Block Diagram

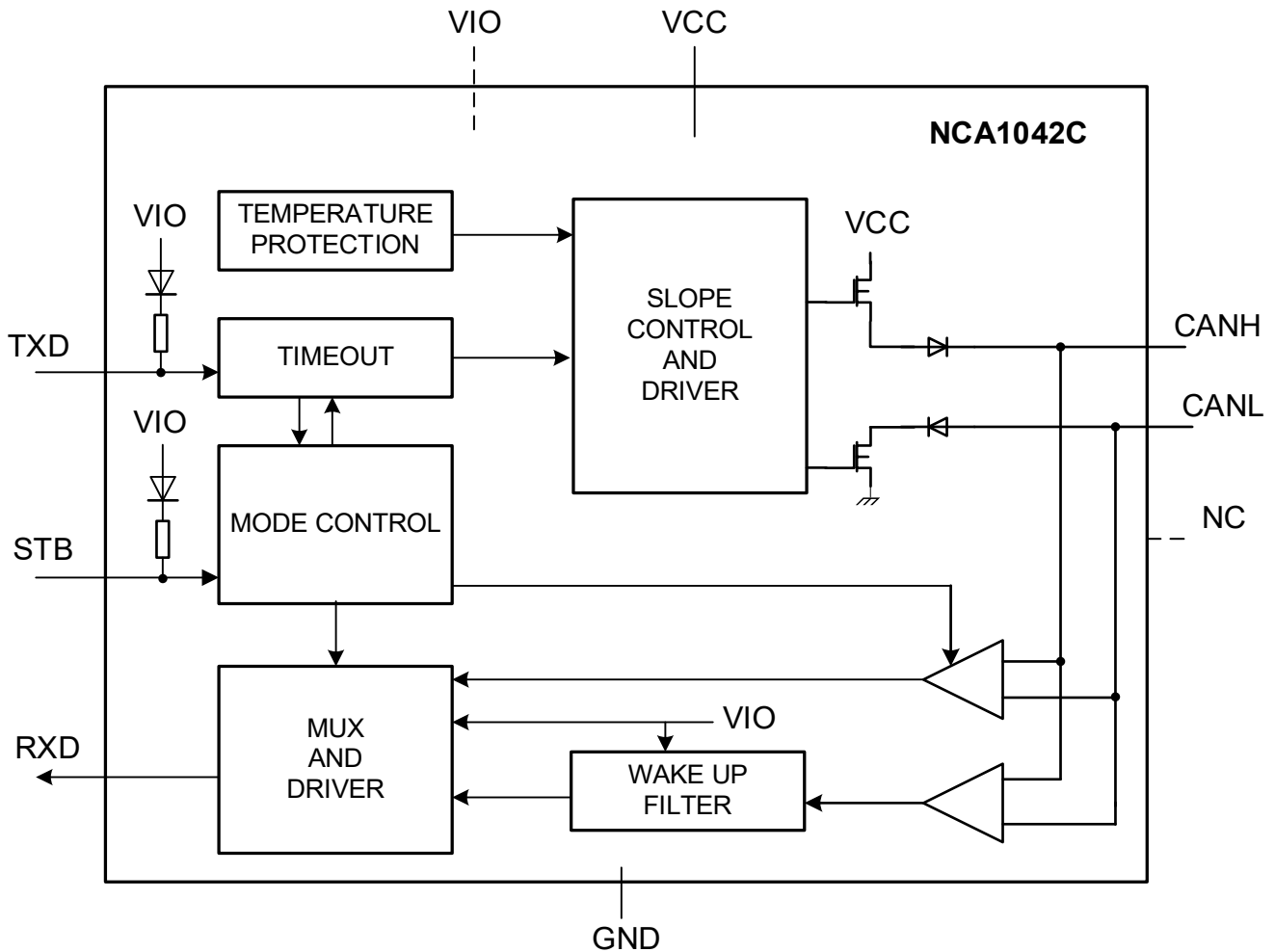

Figure 7-1 Block diagram of NCA1042C

### 7.3. Signal Ringing Reduction

The signal ringing arises from the reflection caused by the impedance mismatch in complex star topologies of CAN network for the sake of the nodes that act as stubs. On a dominant-to-recessive edge, the driver output impedance goes to about 80 k $\Omega$  and signal reflected back experiences impedance mismatch, which causes ringing.

NCA1042C resolves this issue by TX-based signal ringing reduction. Following a dominant-to-recessive edge, transmitter output impedance keeps low (about 100  $\Omega$ ) at first and therefore matches the network characteristic impedance. After the reflections fade away, driver output impedance goes to high-Z and recessive bit is clean at sampling point.

### 7.4. VIO Supply Pin

Two versions of the NCA1042C are available, only differing in the function of a single pin. Pin 5 is either a VIO supply pin or a NC pin.

Pin VIO should be connected to the microcontroller supply voltage (see Figure 8-1 and Figure 8-2). This will adjust the signal levels of pins TXD, RXD and STB to the I/O levels of the microcontroller. Pin VIO also provides the internal supply voltage for the low-power differential receiver of the transceiver. For applications running in low-power mode, this allows the bus lines to be monitored for activity even if there is no supply voltage on pin VCC.

For versions of the NCA1042CN without a VIO pin, the VIO input is internally connected to VCC. This sets the signal levels of pins TXD, RXD and STB to levels compatible with 5 V microcontrollers.

### 7.5. Device Functional Modes

The device has two main operating modes: Normal mode and Standby mode. Operating mode is selected via the STB input pin. Table 7-1 shows a description of the operating modes under normal supply conditions.

Table 7-1 Operating Modes

Mode	STB pin	TXD pin	CAN driver	RXD pin
Normal	LOW	LOW	dominant	LOW
		HIGH	recessive	LOW when bus dominant HIGH when bus recessive
Standby	HIGH	X	GND	Follow bus when wake-up detected
				HIGH when no wake-up detected

#### 7.5.1. Normal Mode

A LOW level on pin STB selects Normal mode. In this mode, the transceiver can transmit and receive data via the bus lines CANH and CANL (see Figure 7-1). The differential receiver converts the analog data on the bus lines into digital data which is output to pin RXD. The slopes of the output signals on the bus lines are controlled internally and are optimized in a way that guarantees the lowest possible Electromagnetic Emission (EME).

After entering normal mode, it is recommended to firstly pull up TXD pin to a high level for at least 200ns before communications, for fear of unwanted TXD timeout caused by unstable TXD level during the power-on phase.

#### 7.5.2. Standby Mode

A HIGH level on pin STB selects Standby mode. In Standby mode, the transceiver is not able to transmit or correctly receive data via the bus lines. The transmitter and Normal-mode receiver blocks are switched off to reduce supply current, and only a low-power differential receiver monitors the bus lines for activity. The wake-up filter on the output of the low-power receiver does not latch bus dominant states, but ensures that only bus dominant and bus recessive states that persist longer than  $t_{\text{tr(wake)bus}}$  are reflected on pin RXD.

In Standby mode, the bus lines are biased to ground to minimize the system supply current. The low-power receiver is supplied by  $V_{\text{IO}}$ , and is capable of detecting CAN bus activity even if  $V_{\text{IO}}$  is the only supply voltage available. When pin RXD goes LOW to signal a wake-up request, a transition to Normal mode will not be triggered until STB is forced LOW.

### 7.6. Remote Wake-up

The NCA1042C wakes up from Standby mode when a dedicated wake-up pattern is detected on the bus (see Figure 7-2). This filtering helps avoid spurious wake-up events. A spurious wake-up sequence could be triggered by, for example, a

dominant clamped bus or by dominant phases due to noise or spikes on the bus. The wake-up pattern must have a complete dominant-recessive-dominant pattern, in which the dominant phase at least has  $t_{wake(bus, dom)}$  and the recessive phase at least has  $t_{wake(bus, rec)}$ , otherwise it will be ignored.

The complete dominant-recessive-dominant pattern must be received within  $t_{to(wake)bus}$  to be recognized as a valid wake-up pattern. Otherwise, the internal wake-up logic is reset. The complete wake-up pattern will then need to be retransmitted to trigger a wake-up event. Pin RXD remains HIGH until the wake-up event has been triggered.

After a wake-up sequence has been detected, the NCA1042C will remain in Standby mode with the bus signals reflected on RXD after  $50\mu s$ . During this  $50\mu s$ , the low-power receiver is on but pin RXD is not active (i.e. HIGH/recessive). The first dominant pulse width  $\geq t_{fltr(wake)bus}$  that ends after the  $50\mu s$  will trigger RXD to go LOW/dominant. Note that dominant or recessive phases lasting less than  $t_{fltr(wake)bus}$  will not be detected by the low-power differential receiver and will not be reflected on RXD in Standby mode.

A wake-up event is not flagged on RXD if any of the following events occurs while a valid wake-up pattern is being received:

- The NCA1042C switches to Normal mode.
- The complete wake-up pattern was not received within  $t_{to(wake)bus}$ .
- A VCC or VIO undervoltage is detected ( $VCC < V_{uvd(VCC)}$  or  $VIO < V_{uvd(VIO)}$ ; see Section 7.7.3).

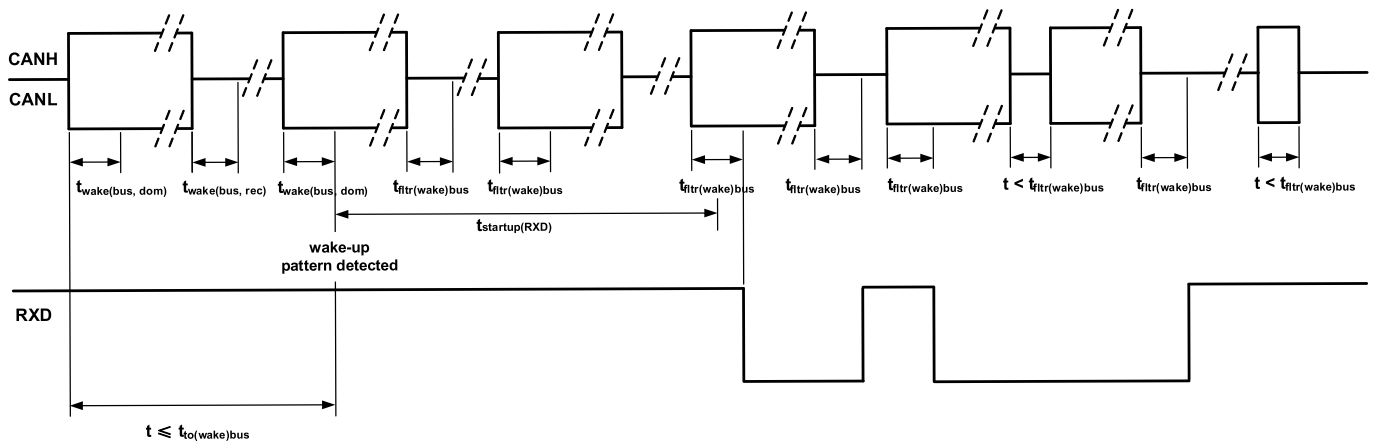

Figure 7-2 Wake-Up Timing

## 7.7. Fail-safe features

### 7.7.1. TXD Dominant Time-Out Function (TXD DTO)

A 'TXD dominant time-out' timer circuit prevents the bus lines from being driven to a permanent dominant state (blocking all network communication) if pin TXD is forced permanently LOW by a hardware and/or software application failure. The timer is triggered by a negative edge on pin TXD.

If the duration of the LOW level on pin TXD exceeds the internal timer value  $t_{to(dom)TXD}$ , the transmitter is disabled, driving the bus lines into a recessive state. The timer is reset by a positive edge on pin TXD. The TXD dominant time-out time also defines the minimum possible bit rate of 10 kbit/s.

### 7.7.2. Internal Biasing of TXD and STB Input Pins

Pins TXD and STB have internal pull-ups to VIO to ensure a safe, defined state, in case one or both of these pins are left floating. Pull-up currents flow in these pins in all states; both pins should be held HIGH in Standby mode to minimize standby current.

### 7.7.3. Undervoltage Detection on Pins VCC and VIO

The supply terminals have undervoltage detection that places the device in protected mode. This protects the bus during an undervoltage event on either the VCC or VIO supply terminals. When VCC drop below the VCC undervoltage detection level,  $V_{uvd(VCC)}$ , the transceiver will switch to Standby mode. The logic state of pin STB will be ignored until VCC has recovered. When VIO drop below the VIO undervoltage detection level,  $V_{uvd(VIO)}$ , the transceiver will switch off and disengage from the bus (zero load) until VIO has recovered.

After an undervoltage condition is cleared and the supplies have returned to valid levels, the device typically resumes normal operation within 50  $\mu$ s.

Table 7-2 Undervoltage Lockout 5V Only Devices (NCA1042CN)

VCC	Device State	Bus Output	RXD
$>UV_{VCC}$	Normal	Per TXD	Mirrors Bus <sup>[1]</sup>
$<UV_{VCC}$	Off	High Impedance	High Impedance

<sup>[1]</sup> Mirrors bus state: low if CAN bus is dominant, high if CAN bus is recessive.

Table 7-3 Undervoltage Lockout I/O Level Shifting Devices (NCA1042C)

VCC	VIO	Device State	Bus Output	RXD
$>UV_{VCC}$	$>UV_{VIO}$	Normal	Per TXD	Mirrors Bus <sup>[1]</sup>
$<UV_{VCC}$	$>UV_{VIO}$	Standby Mode	GND	Bus Wake RXD Request <sup>[2]</sup>
$>UV_{VCC}$	$<UV_{VIO}$	Off	High Impedance	High Impedance
$<UV_{VCC}$	$<UV_{VIO}$	Off	High Impedance	High Impedance

<sup>[1]</sup> Mirrors bus state: low if CAN bus is dominant, high if CAN bus is recessive.

<sup>[2]</sup> Refer to Section 7.6.

### 7.7.4. Unpowered Device

The device is designed to be 'ideal passive' or 'no load' to the CAN bus if it is unpowered. The bus terminals (CANH, CANL) have extremely low leakage currents when the device is unpowered to avoid loading down the bus. This is critical if some nodes of the network are unpowered while the rest of the of network remains in operation. The logic terminals also have extremely low leakage currents when the device is unpowered to avoid loading down other circuits that may remain powered.

### 7.7.5. Over-Temperature Protection (OTP)

The output drivers are protected against over-temperature conditions. If the virtual junction temperature exceeds the shutdown junction temperature  $T_{SD}$ , the output drivers will be disabled until the virtual junction temperature becomes lower than  $T_{SD}$  and TXD becomes recessive again. By including the TXD condition, the occurrence of output driver oscillation due to temperature drifts is avoided.

**7.7.6.Short Circuit Protection**

The current limiting circuit of the CANH and CANL can protect the transceiver from damage when they are short to GND or a supply voltage during communication. If the device heats up to over temperature threshold due to a continuous short on the CANH or CANL, the internal overtemperature protection switches off the bus transmitter.

## 8. Application Note

### 8.1. Typical Application

The NCA1042C requires a 0.1  $\mu\text{F}$  bypass capacitors between VCC and GND. The capacitor should be placed as close as possible to the package. The Figure 8-1 and Figure 8-2 are the typical applications of NCA1042C.

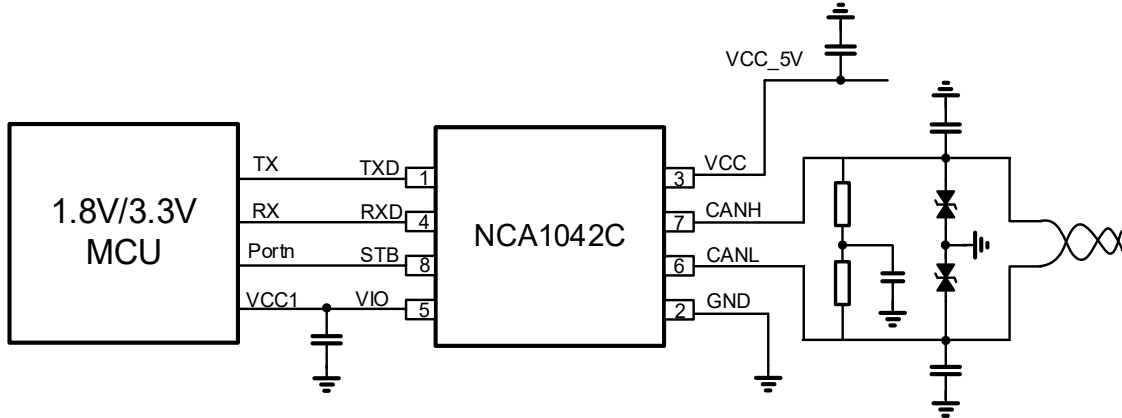

Figure 8-1 Typical CAN Bus Application Using 1.8V/3.3V CAN Controller

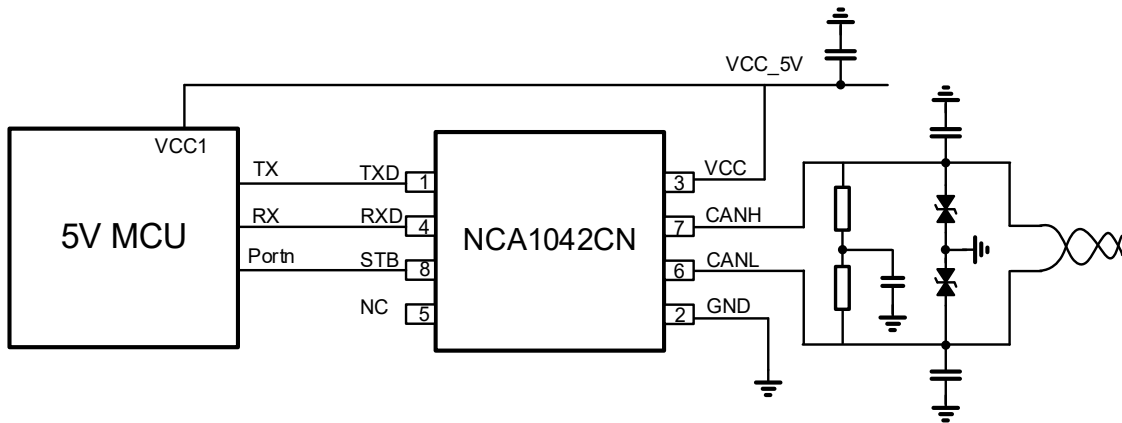
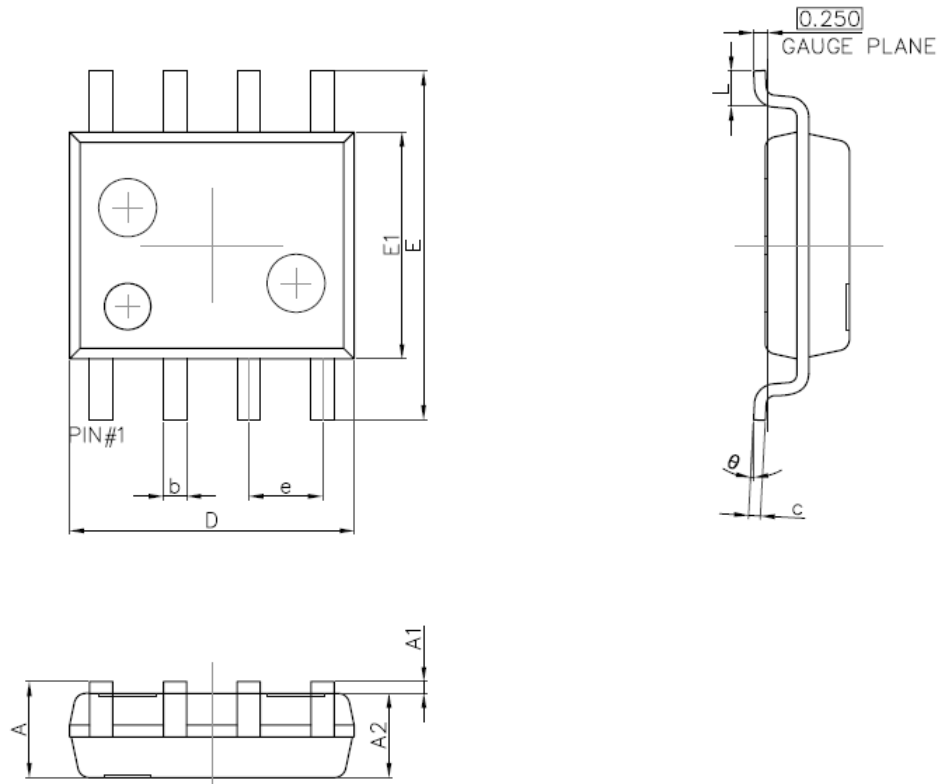

Figure 8-2 Typical CAN Bus Application Using 5V CAN Controller

### 9. Package Information



Symbol	Dimensions In Millimeters		Dimensions In Inches	
	Min.	Max.	Min.	Max.
A	1.450	1.750	0.057	0.069
A1	0.100	0.250	0.004	0.010
A2	1.350	1.550	0.053	0.061
b	0.330	0.510	0.013	0.020
c	0.170	0.250	0.007	0.010
D	4.700	5.100	0.185	0.201
E	5.800	6.200	0.228	0.244
E1	3.800	4.000	0.150	0.157
e	1.270(BSC)		0.050(BSC)	
L	0.400	1.270	0.016	0.050
θ	0°	8°	0°	8°

Figure 9-1 SOP8 Package Shape and Dimension

## 10. Ordering Information

<i>Part Number</i>	<i>Operation Temperature</i>	<i>MSL</i>	<i>Package Type</i>	<i>SPQ</i>
NCA1042C-DSPR	-40 to 125°C	3	SOP8	2500
NCA1042CN-DSPR	-40 to 125°C	3	SOP8	2500
NCA1042C-DSPRH	-40 to 125°C	3	SOP8	2500
NCA1042CN-DSPRH	-40 to 125°C	3	SOP8	2500

## 11. Documentation Support

<i>Part Number</i>	<i>Product Folder</i>	<i>Datasheet</i>	<i>Technical Documents</i>
NCA1042C	<a href="#">Click here</a>	<a href="#">Click here</a>	<a href="#">Click here</a>

## 12. Tape and Reel Information

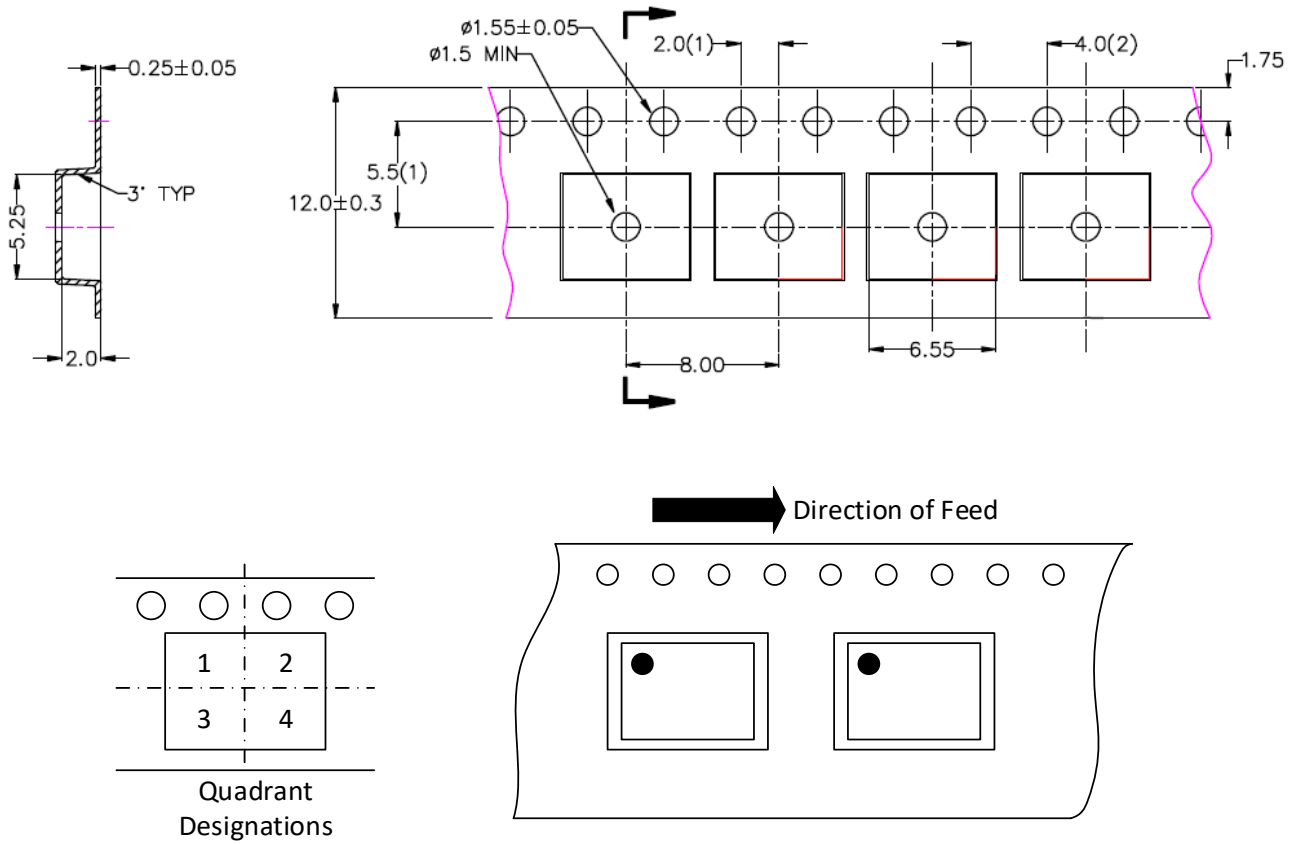
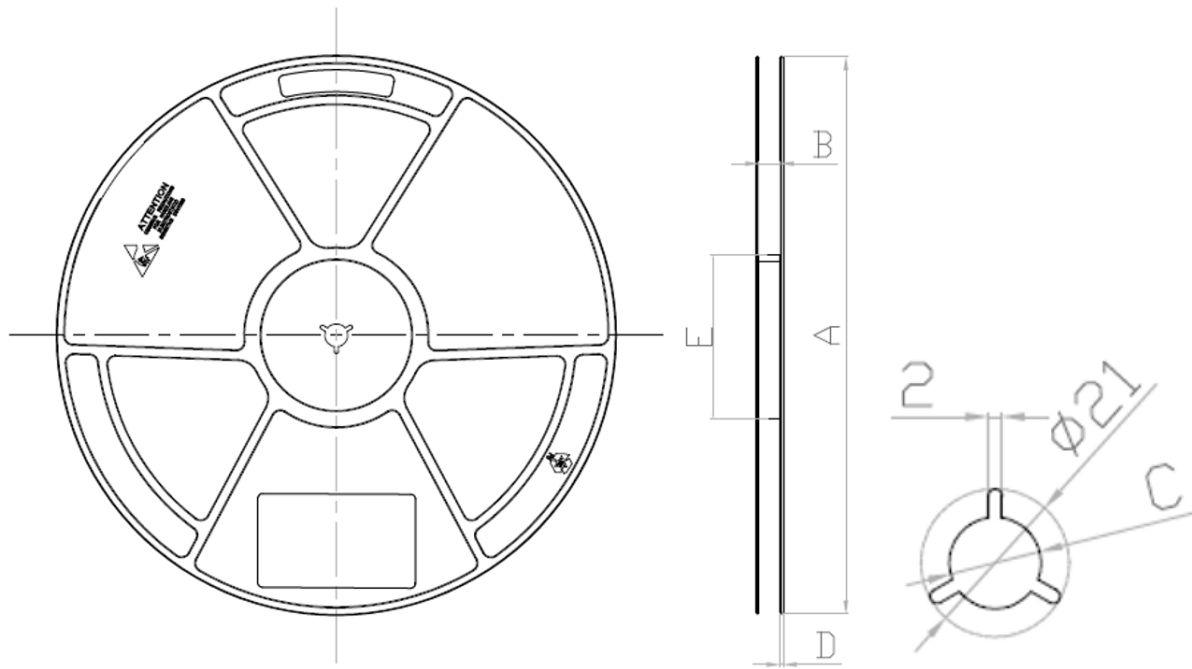

Figure 12-1 Tape Information of SOP8



规格	A	B	C	D	E
12W	330±2.0	12.5±1.00	13.5±1.00	1.9±1.00	100±1.00
16W	330±2.0	16.5±1.00	13.5±1.00	1.9±1.00	100±1.00
24W	330±2.0	24.5±1.00	13.5±1.00	1.9±1.00	100±1.00
32W	330±2.0	32.5±1.00	13.5±1.00	1.9±1.00	100±1.00
44W	330±2.0	44.5±1.00	13.5±1.00	1.9±1.00	100±1.00

Figure 12-2 Reel Information of SOP8

### 13. Revision History

Revision	Description	Date
1.0	Initial Version.	2024/9/30
1.1	Add the parameter- $t_{startup(RXD)}$ and the description of short circuit protection, Add system-level ESD parameters and modified SOP8 carrier information	2024/12/24
1.2	Correct common mode voltage information error; Add H version device and update ESD parameters; Update Loop Time Voltage Waveforms in Figure 6-4	2026/03/24

## IMPORTANT NOTICE

The information given in this document (the “Document”) shall in no event be regarded as any warranty or authorization of, express or implied, including but not limited to accuracy, completeness, merchantability, fitness for a particular purpose or infringement of any third party’s intellectual property rights.

Users of this Document shall be solely responsible for the use of NOVOSENSE’s products and applications, and for the safety thereof. Users shall comply with all laws, regulations and requirements related to NOVOSENSE’s products and applications, although information or support related to any application may still be provided by NOVOSENSE.

This Document is provided on an “AS IS” basis and is intended only for skilled developers designing with NOVOSENSE’ products. NOVOSENSE reserves the rights to make corrections, modifications, enhancements, improvements or other changes to the products and services provided without notice. NOVOSENSE authorizes users to use this Document exclusively for the development of relevant applications or systems designed to integrate NOVOSENSE’s products. No license to any intellectual property rights of NOVOSENSE is granted by implication or otherwise. Using this Document for any other purpose, or any unauthorized reproduction or display of this Document is strictly prohibited. In no event shall NOVOSENSE be liable for any claims, damages, costs, losses or liabilities arising out of or in connection with this Document or the use of this Document.

For further information on applications, products and technologies, please contact NOVOSENSE ([www.novosns.com](http://www.novosns.com)).

**Suzhou NOVOSENSE Microelectronics Co., Ltd**