

## 1.7V~3.6V, Unidirectional Linear Hall Effect Sensor IC with Tri-State Output and User-Selectable Sleep Mode

### 1 Product Description

The MT936X series product is a low-voltage, low-power linear Hall-effect IC with sleep mode by user-selectable. The MT936X can work under the ultra-low operating voltage from 1.7V~3.6V. In addition, by setting  $\overline{SLEEP} < VINL$ , the chip change to sleep mode, and the current consumption is only 25uA. At this time, the output of the chip change to "high-impedance state" and does not respond to the change of the external magnetic field; By setting  $\overline{SLEEP} > VINH$ , the chip change to active mode. The current consumption is 2mA, and the output is proportional to the induced magnetic field.

The  $\overline{SLEEP}$  pin can be set to select the sleep and awake mode to help users further reduce power consumption. Therefore, it is very suitable for battery powered applications. In the sleep mode, since the output changes to "high resistance state", multiple chips can share one ADC interface.

The output of the MT936XDT-2030 series products is proportional to the VREF pin. When there is no magnetic field,  $V_{OUT} = 6.47\%$  of VREF ( $V_{CC} = V_{REF} = 3.0V$ ), so it is not related to the power supply. In addition, the MT936X series is only sensitive to south pole proportionally.

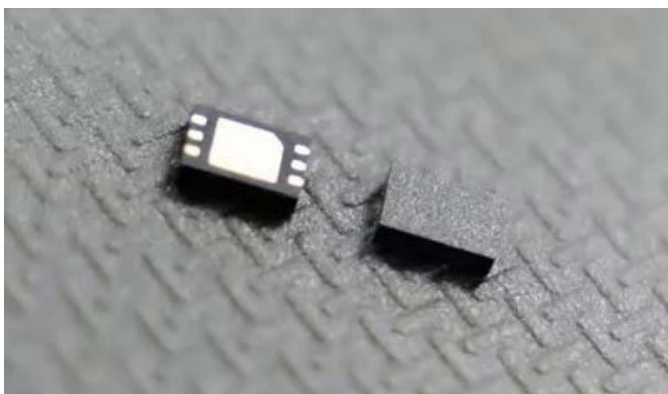

### 2 Features

- COMS Technology
- 1.7~3.6V Operating VCC Range
- -20~85°C Operating Temperature
- Low current consumption  
 MT936XDT-2030:  
 $\overline{SLEEP} < VINL$ ,  $I_{CC} = 25\mu A$   
 $\overline{SLEEP} > VINH$ ,  $I_{CC} = 2mA$   
 MT936XET:  
 $I_{CC} = 2mA$
- Magnetic Sensitivity Option: (only sensitive to S pole)  
 3.78mV/Gs MT9363DT-2030 @  $V_{CC} = V_{REF} = V_{CCN}$   
 10.0mV/Gs MT9365DT-2030 @  $V_{CC} = V_{REF} = V_{CCN}$   
 3.78mV/Gs MT9363ET @  $V_{CC} = 3V$   
 10.0mV/Gs MT9365ET @  $V_{CC} = 3V$
- User-Selectable Sleep Mode(only MT936XDT-2030)
- High-impedance output during sleep mode
- The output voltage is proportional to the reference voltage (VREF pin)
- Package Option : DFN-2030/SOT-23(Thin outline)
- RoHS Compliant : (EU)2015/863

### 3 Applications

- Position Detection
- Magnetic scale
- AR/VR handle trigger
- Game 3D joystick
- Keyboard
- Battery-Powered Devices

### 4 Selection Guide

Ordering P/N	Sensitivity (mV/Gs)	Package	Qty per Reel (pcs)
MT9363DT-2030	3.78	DFN-2030	3000
MT9365DT-2030	10	DFN-2030	3000
MT9363ET	3.78	SOT-23(Thin outline)	3000
MT9365ET	10	SOT-23(Thin outline)	3000

## Table of Contents

1	Product Description.....	1
2	Feature.....	1
3	Applications .....	1
4	Selection Guide.....	1
5	Transfer Characteristics.....	3
6	Feature Description.....	3
7	Functional Block Diagram.....	4
8	Pin Configuration and Function.....	4
9	Electrical and Magnetic Characteristics.....	5
	9.1 Absolute Maximum Ratings.....	5
	9.2 ESD Ratings.....	5
	9.3 Electrical Specifications.....	6
	9.4 Timing Diagram of Chip Working Status.....	8
	9.5 Characteristic Performance.....	9
10	Typical Application Circuit.....	10
11	Package Material Information .....	11
	11.1 DFN-2030 Package Information.....	11
12	Copy Rights and Disclaimer.....	12

## Reversion History

- 1 Originally Version

### 5 Transfer Characteristics

Figure.1 shows three sensitivity options enable maximal output voltage swing based on the required sensing range.

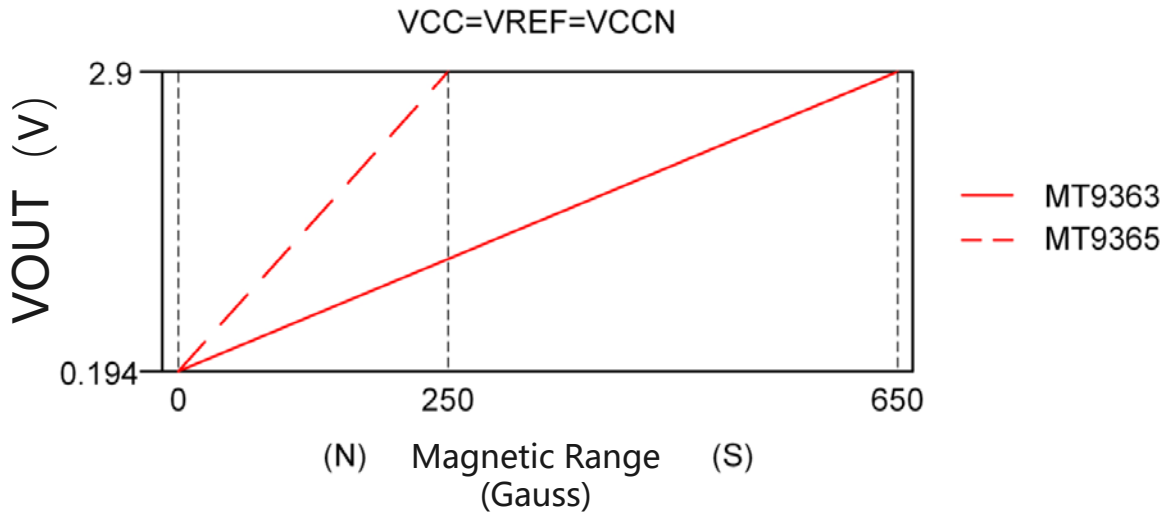

Figure.1 Transfer Characteristics

### 6 Feature Description

The MT936X is sensitive to the magnetic field that is perpendicular to the top of the chip package.

When the south pole magnetic field continuously close to the IC from the top, which showed in the left of the Figure.2, the VOUT changing from 0.194 to 2.9V linearity. (VCC=VREF=VCCN)

When the south pole magnetic field  $\geq +650\text{Gs}$  (MT9363) or  $\geq +250\text{Gs}$  (MT9365), which showed in the right of the Figure.2, the VOUT will keep 2.9V. (VCC=VREF=VCCN)

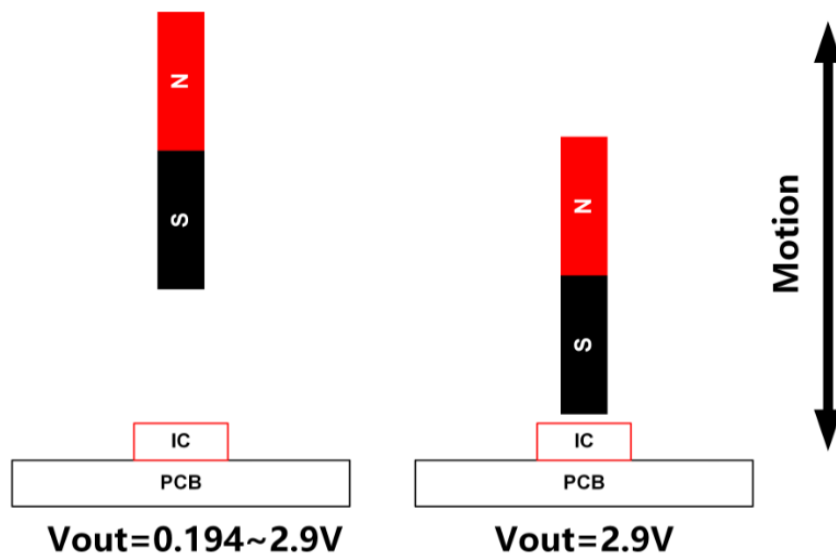

Figure.2 Feature Description

### 7 Functional Block Diagram

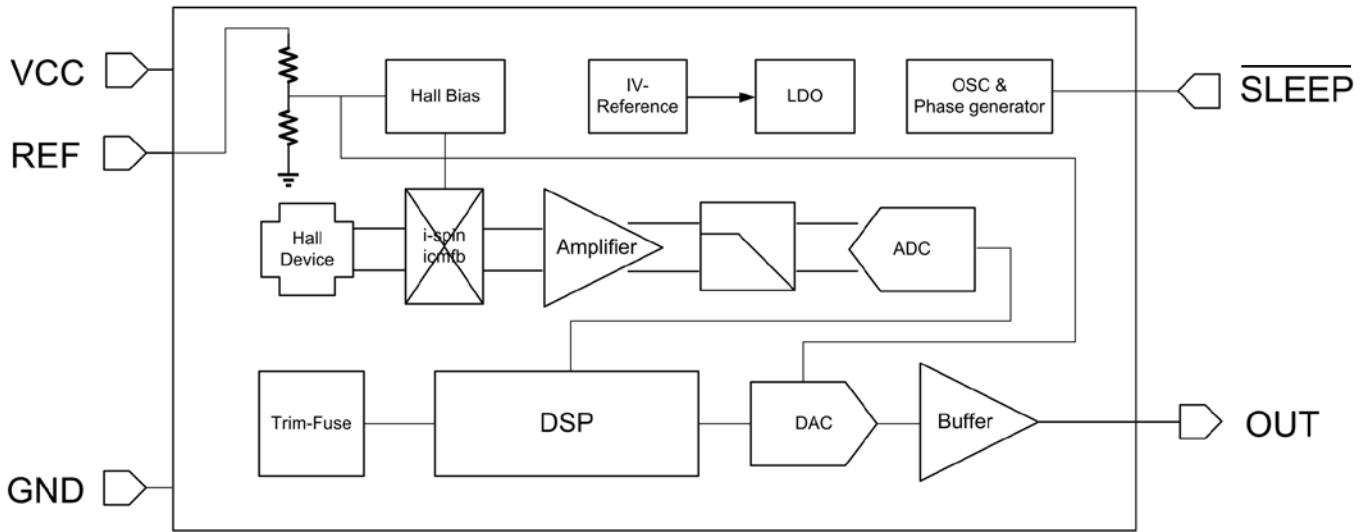

Figure.3 Functional Block Diagram

### 8 Pin Configuration and Function

	VCC	OUT	GND	GND	SLEEP	VREF	GND
DFN-2030	1	2	3	4	5	6	7
SOT-23 (Thin outline)	1	2	3	NA	NA	NA	NA
Description	Supply	Output	Ground	Ground	Toggle sleep mode	Supply for ratiometric reference	Ground

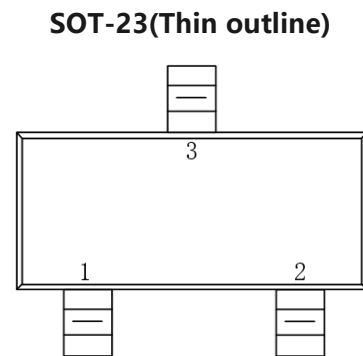
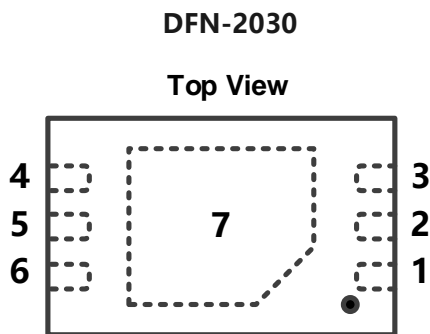

Figure.4 Pin Configuration & Functions

## 9 Electrical and Magnetic Characteristics

### 9.1 Absolute Maximum Ratings

Absolute maximum ratings are limited values to be applied individually, and beyond which the serviceability of the circuit may be impaired. Functional operability is not necessarily implied. Exposure to absolute maximum rating conditions for an extended period of time may affect device reliability.

Symbol	Parameters	Min	Max	Units
VCC	Supply Voltage	-	6	V
VRCC	Reverse Battery Voltage	-0.1	-	V
VREF	Ratiometric Supply Reference Voltage	-	6	V
VRREF	Reverse Ratiometric Supply Reference Voltage	-0.1	-	V
VSLEEP	Logic Supply Voltage	-	6	V
VRSLEEP	Reverse-Logic Supply Voltage	0.1	-	V
VOUT	Output Voltage	-	VCC+0.1	V
IOUT	Continuous Output Current	-	10	mA
TA	Operating Ambient Temperature	-20	85	°C
TS	Storage Temperature	-50	150	°C
TJ	Junction Temperature	-	150	°C

### 9.2 ESD Ratings

Symbol	Parameters	Reference	Class
VESD	Human-body model (HBM)	AEC-Q100-002	Class II
	Charged-device model (CDM)	AEC-Q100-011	Class C3
	Latch up	AEC-Q100-004	Class IA

### 9.3 Electrical Specifications

At  $T_A = -20 \sim 85 \text{ }^\circ\text{C}$ ,  $V_{CC} = 1.7\text{V} \sim 3.6\text{V}$ ,  $C_{BYPASS} = 0.1\mu\text{F}$  (unless otherwise specified)

Symbol	Parameters	Test Condition	Min	Typ	Max	Unit
VCC <sup>1)</sup>	Supply Voltage	-	1.7	-	3.6	V
VCCN <sup>2)</sup>	Nominal Supply Voltage	-	-	3.0	-	V
VREF <sup>1) 2)</sup>	Ratiometric Reference Voltage		1.8	-	VCC	V
VINH <sup>2)</sup>	Active Threshold Voltage	For active mode	-	0.45 x VCC	-	V
VINL <sup>2)</sup>	SLEEP Threshold Voltage	For sleep mode	-	0.20 x VCC	-	V
RREF <sup>2)</sup>	Ratiometric Reference Input Resistance	$T_A = 25^\circ\text{C}$	250	-	-	k $\Omega$
ICC	Supply Current	$V_{SLEEP} > V_{INH}^{2)}$ , $V_{CC} = V_{CCN}$ , $T_A = 25^\circ\text{C}$	-	2	-	mA
		$V_{SLEEP} < V_{INL}^{2)}$ , $V_{CC} = V_{CCN}$ , $T_A = 25^\circ\text{C}$	-	20	-	$\mu\text{A}$
		MT936XET: $T_A = 25^\circ\text{C}$	-	2	-	mA
TPO	Power-On Time	$T_A = 25^\circ\text{C}$	-	75	-	$\mu\text{s}$
Tawake <sup>2)</sup>	Awake Time	$T_A = 25^\circ\text{C}$ , sleep to active	-	25	-	$\mu\text{s}$
Tsleep <sup>2)</sup>	Sleep Time	$T_A = 25^\circ\text{C}$ , active to sleep	-	1	-	$\mu\text{s}$
BW	Bandwidth	-3dB, $C_L = 1\text{nF}$ , $V_{CC} = V_{CCN}$	-	10	-	KHz
ROUT	Output Resistance	$I_{OUT} < 1.5\text{mA}$ , $V_{CC} = V_{CCN}$ $N$ $V_{SLEEP} > V_{INH}$ , $B = 0\text{Gs}$	-	5	10	$\Omega$
		$I_{OUT} < 1.5\text{mA}$ , $V_{CC} = V_{CCN}$ $N$ $V_{SLEEP} < V_{INL}$ , $B = 0\text{Gs}$	4	-	-	M $\Omega$
RL	Output Load Resistance	Output to ground	4.7	-	-	K $\Omega$
		Output to Supply	4.7	-	-	K $\Omega$
CL	Output Load Capacitance	OUT to GND	-	-	10	nF
VOL <sup>1)</sup>	Linear Output Low Voltage	$V_{CC} = V_{CCN}$ , $R_L \geq 4.7\text{K}\Omega$	-	-	0.1	V
VOH <sup>1)</sup>	Linear Output High Voltage	$V_{CC} = V_{CCN}$ $R_L \geq 4.7\text{K}\Omega$	VREF-0.1	-	-	V

1)  $V_{REF} \leq V_{CC}$

2) Only for MT936XDT-2030

*Continued on next page...*

**Electrical Specifications(Continued from previous page)**

 At  $T_A = -20 \sim 85^\circ\text{C}$ ,  $V_{CC} = 1.7 \sim 3.6\text{V}$ ,  $C_{BYPASS} = 0.1\mu\text{F}$  (unless otherwise specified)

Symbol	Parameters	Test Condition	Min	Typ	Max	Unit
TRESP	Response Time	$T_A = 25^\circ\text{C}$ , $B = B(\text{max})$ $V_{CC} = V_{REF} = V_{CCN}$	-	36	-	us
TR	Rise Time	$T_A = 25^\circ\text{C}$ , $B = B(\text{max})$ $V_{CC} = V_{REF} = V_{CCN}$	-	18	-	us
TPD	Propagation Delay	$T_A = 25^\circ\text{C}$ , $B = B(\text{max})$ $V_{CC} = V_{REF} = V_{CCN}$	-	19	-	us
ELIN	Linearity	$T_A = 25^\circ\text{C}$ , $V_{OUT} = 0.1\text{V} \sim V_{REF} - 0.1\text{V}$	-1.5	-	1.5	%
VOQ	Quiescent Voltage	$T_A = 25^\circ\text{C}$ , $B = 0\text{Gs}$	-	6.47	-	%VREF
VOE	Quiescent Voltage Error	$T_A = 25^\circ\text{C}$ , $B = 0\text{Gs}$ $V_{CC} = V_{REF} = V_{CCN}$	0.168	0.194	0.220	V
SNST	Sensitivity	MT9363, $T_A = 25^\circ\text{C}$ , $V_{CC} = V_{REF} = V_{CCN}$	3.52	3.78	4.04	mV/Gs
		MT9365, $T_A = 25^\circ\text{C}$ , $V_{CC} = V_{REF} = V_{CCN}$	9.30	10.00	10.7	mV/Gs
VOQ_TC	VOQ Variation Over Temperature	-	-2	-	2	%
SNST_TC	SNST Variation Over Temperature	-	-	1100	-	ppm/ $^\circ\text{C}$
ERAT_VOQ	Ratiometry Quiescent Voltage Output Error	$T_A = 25^\circ\text{C}$ , $V_{REF} = 1.7 \sim 1.9\text{V}$	-2.5	-	2.5	%
		$T_A = 25^\circ\text{C}$ , $V_{REF} = 2.7 \sim 3.3\text{V}$	-2.5	-	2.5	%
ERAT_SNST	Ratiometry Sensitivity Error	$T_A = 25^\circ\text{C}$ , $V_{REF} = 1.7 \sim 1.9\text{V}$	-2	-	2	%
		$T_A = 25^\circ\text{C}$ , $V_{REF} = 2.7 \sim 3.3\text{V}$	-2	-	2	%
VN	Noise	MT9363	-	35	-	mVpp
		MT9365	-	75	-	mVpp

### 9.4 Timing Diagram of Chip Working Status

The MT936X is low-power Hall effect sensor IC that perfect for power sensitive customer applications. The current consumption of MT936X is 2mA typically, while the device is in the active mode, and 25µA when the device is in the sleep mode. Toggling the logic level signal through the SLEEP pin drives the device into either the active mode or the sleep mode.

A logic low signal drives the device into the sleep mode, while a logic high signal drives the device into the active mode through the SLEEP pin.

In the case in which the VREF pin is powered before the VCC pin, the device will not operate within the specified limits until the supply voltage is equal to the reference voltage. When the device is switched from the sleep mode to the active mode, a time defined by TPON must elapse before the output of the device is valid. The device output transitions into the high impedance state approximately TPOFF after a logic low signal is applied to the SLEEP pin (refer to figure 5).

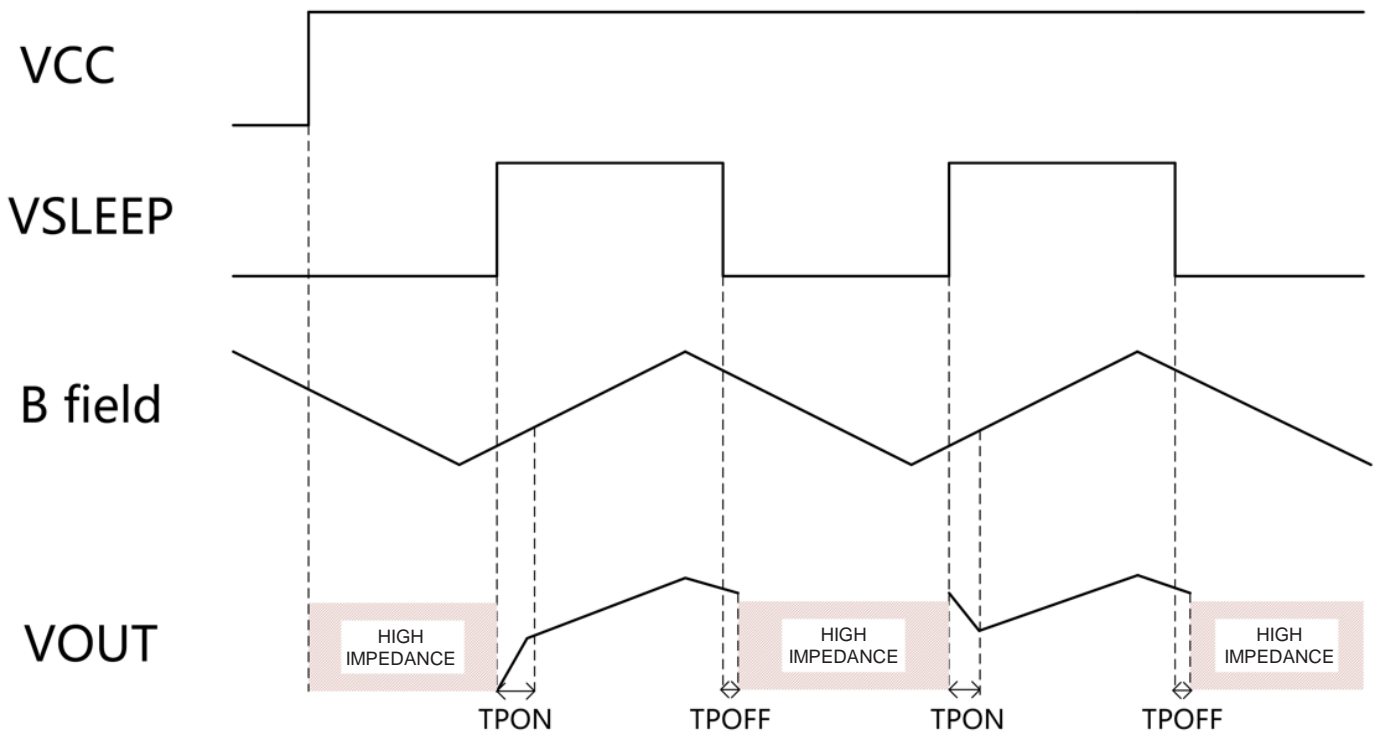

Figure.5 Timing diagram of chip working status

### 9.5 Characteristic Performance

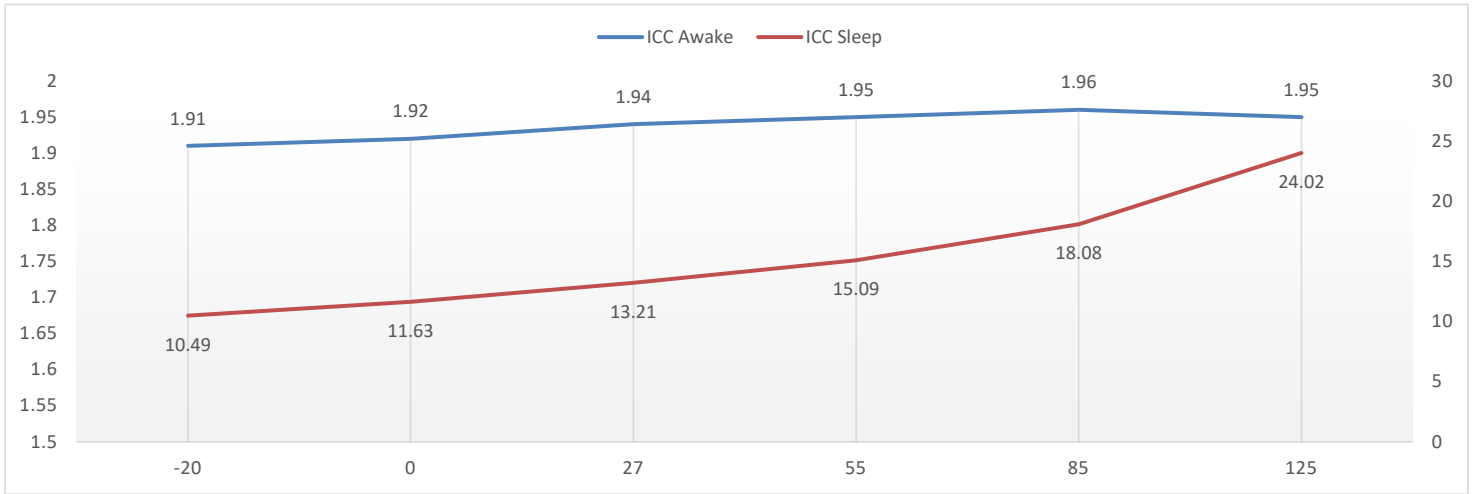

Figure.6 Icc of Awake & Sleep Mode vs. Temperature

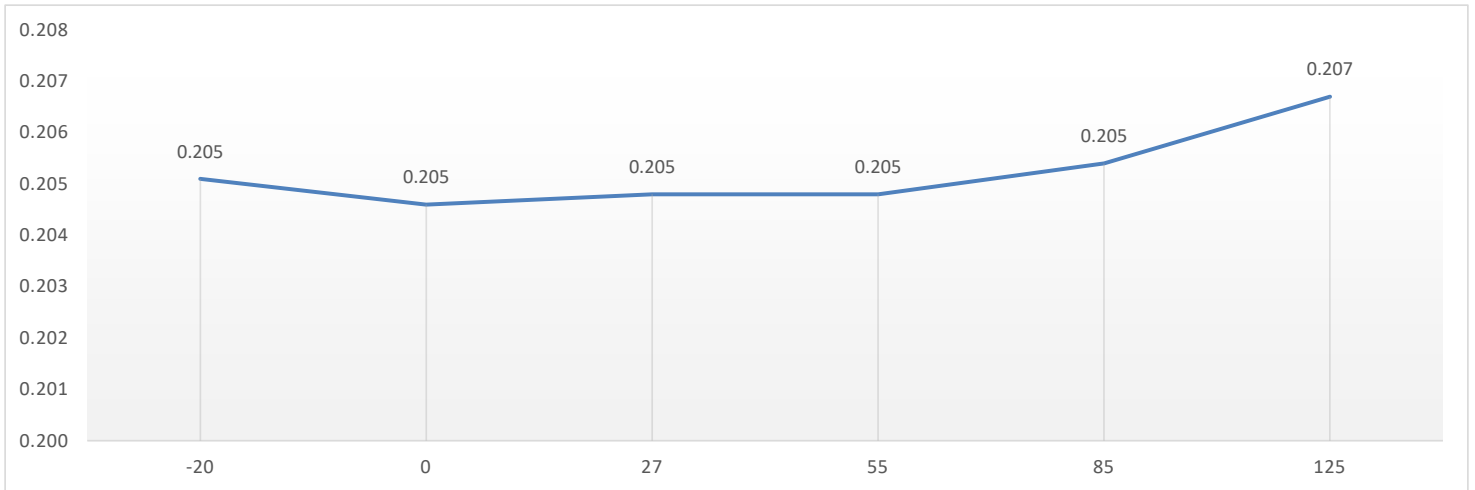

Figure.7 VOE vs. Temperature

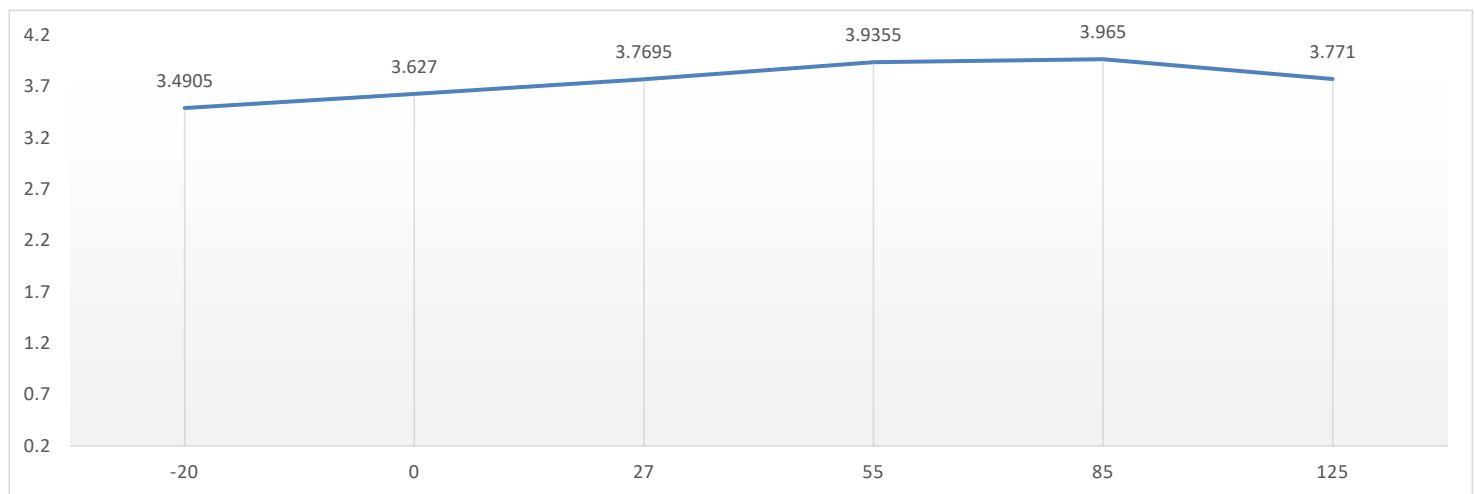
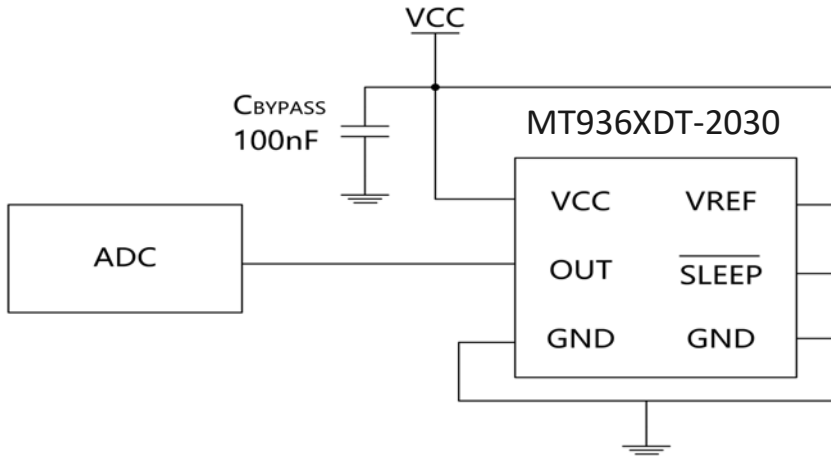

Figure.8 Sensitivity vs. Temperature

### 10 Typical Application Circuit

MT936XDT-2030 as example



MT936XET as example

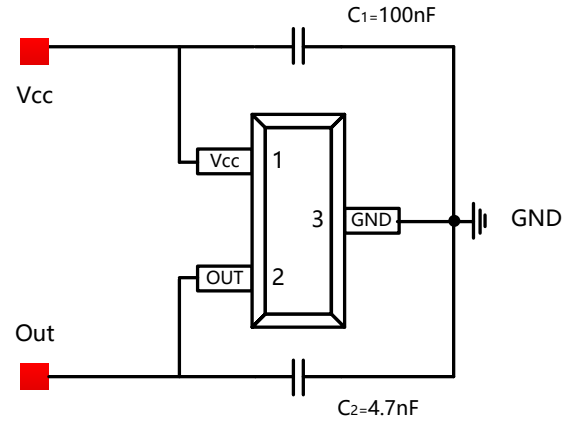

Figure.9 Active Mode Application Circuit

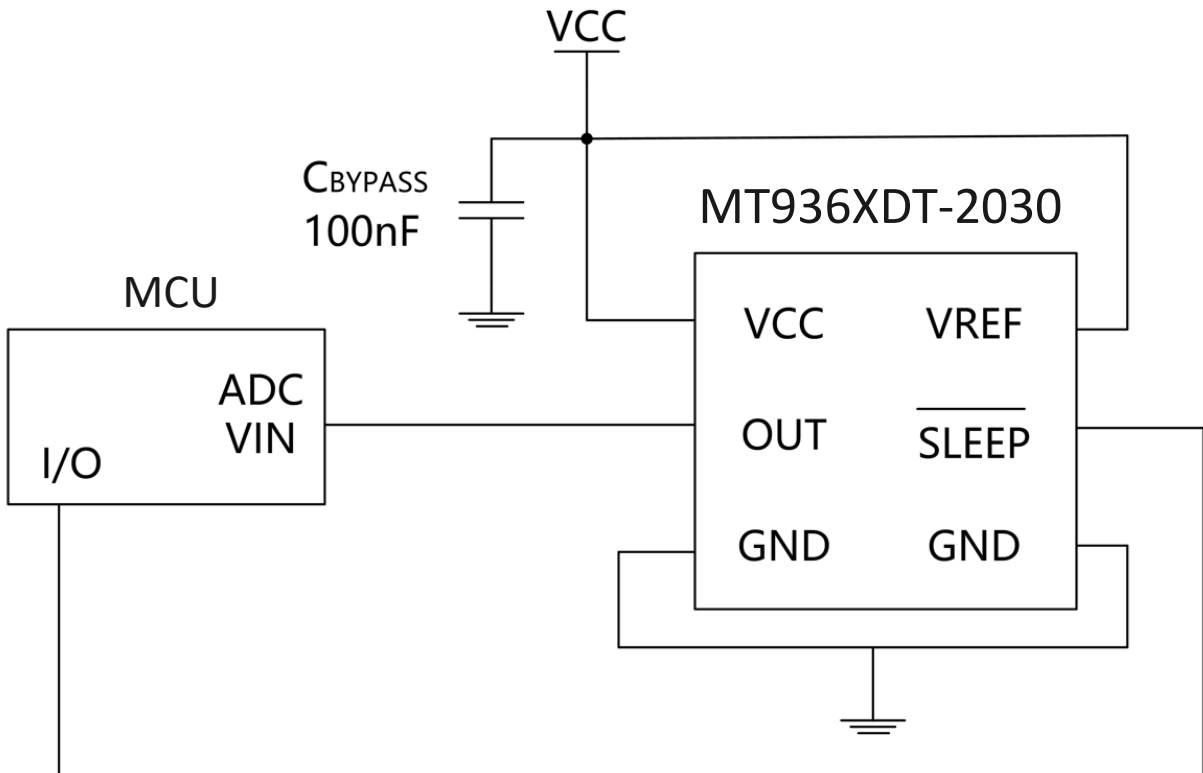

Figure.10 User-Selectable Sleep Mode Application Circuit

## 11 Package Material Information (For Reference Only)

### 11.1 DFN-2030 Package Information

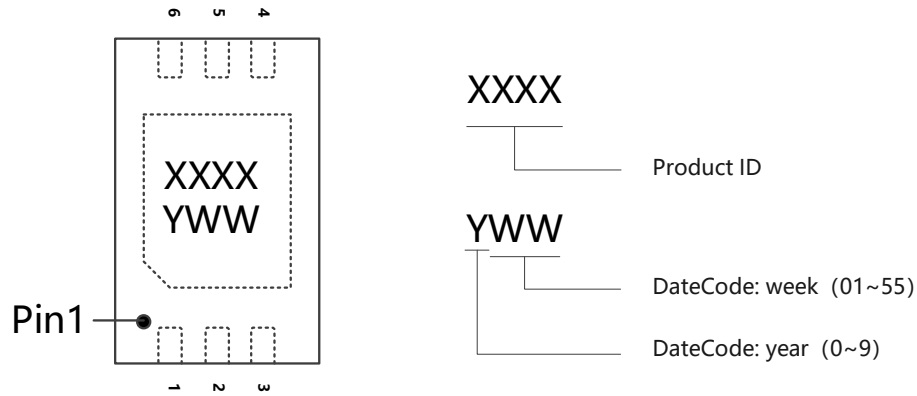

Figure.11 DFN-2030 Chip Marking Spec

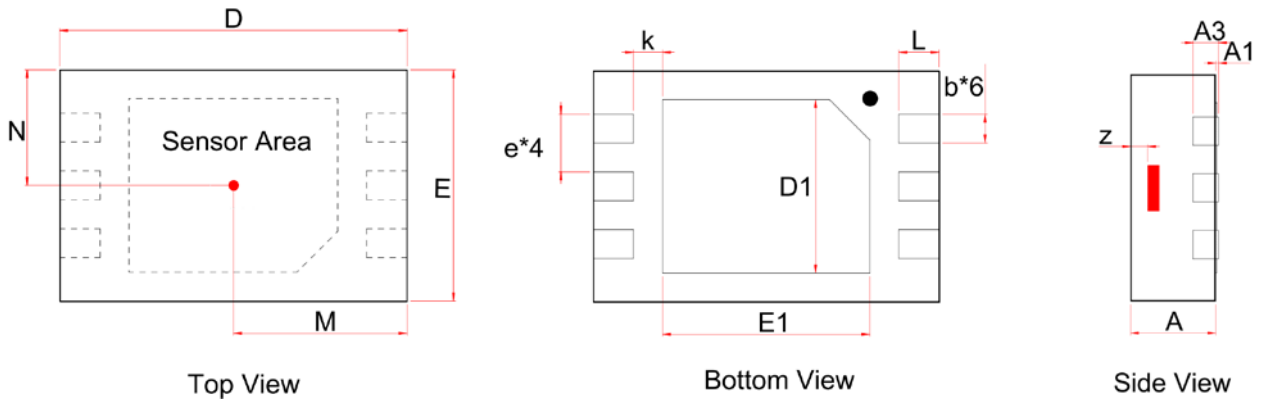
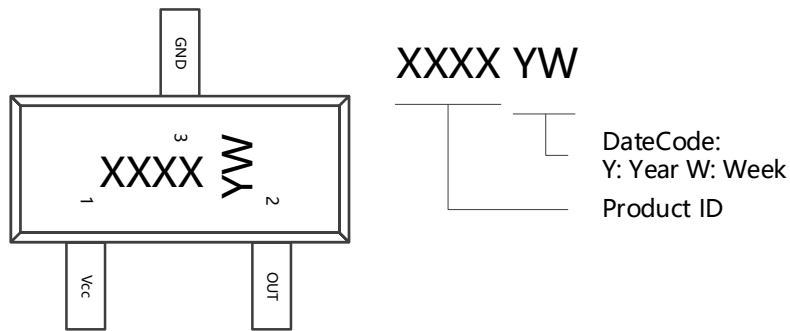

Figure.12 DFN-2030 Package Drawing

Symbol	Dimensions in Millimeters		Dimensions in Inches	
	Min	Max	Min	Max
A	0.700	0.800	0.028	0.031
A1	0.000	0.050	0.000	0.002
A3	0.203 REF		0.008 REF	
D	2.950	3.050	0.116	0.120
E	1.950	2.050	0.077	0.081
D1	1.400	1.600	0.055	0.063
E1	1.600	1.800	0.063	0.071
b	0.200	0.300	0.008	0.012
e	0.500 TYP		0.020 TYP	
k	0.200 MIN		0.008 MIN	
L	0.300	0.400	0.012	0.016
M	1.500 TYP		0.060 TYP	
N	1.000 TYP		0.040 TYP	
z	0.320 TYP		0.013 TYP	

## 11.2 SOT-23 (Thin Outline) Package Information



**Figure.13** SOT-23 (Thin Outline) Chip Marking Spec

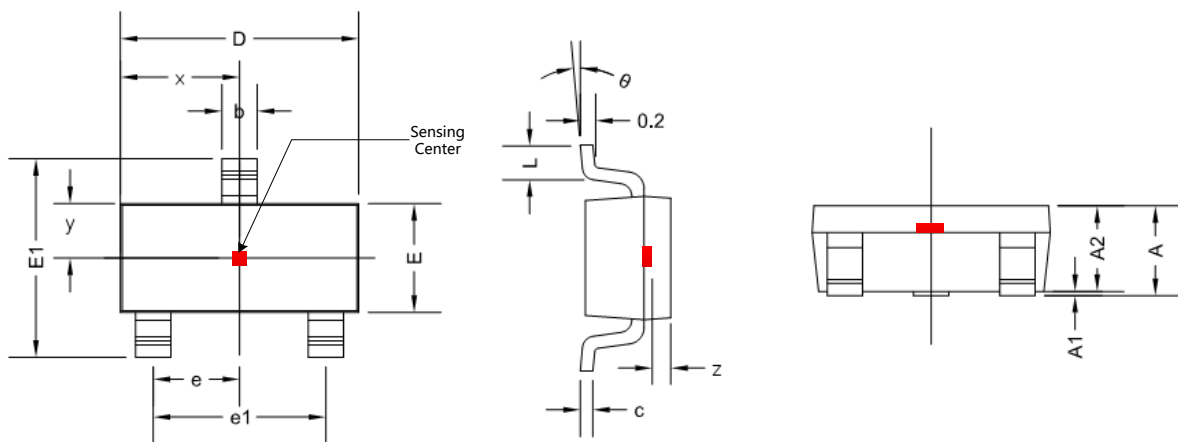

**Figure.14** SOT-23 (Thin Outline) Package Drawing

Symbol	Dimensions in Millimeters		Dimensions in Inches	
	Min	Max	Min	Max
A	0.900	1.150	0.035	0.045
A1	0.000	0.100	0.000	0.004
A2	0.900	1.050	0.035	0.041
b	0.300	0.500	0.012	0.020
c	0.132	0.202	0.005	0.008
D	2.800	3.000	0.110	0.118
E	1.200	1.400	0.047	0.055
E1	2.250	2.550	0.089	0.100
e	0.950 TYP		0.037 TYP	
e1	1.800	2.000	0.071	0.079
L	0.550 REF		0.022 REF	
L1	0.300	0.500	0.012	0.020
θ	0 °	8 °	0 °	8 °
x	1.460 TYP		0.057 TYP	
y	0.650 TYP		0.026 TYP	
z	0.350 TYP		0.014 TYP	

## 12 Copy Rights and Disclaimer

1. This document may not be reproduced or duplicated, in any form, in whole or in part without prior written consent of MagnTek . Copyrights © 2019, MagnTek Incorporated.
2. MagnTek reserves the right to make changes to the information published in this document at anytime without notice.
3. MagnTek' s products are limited for use in normal commercial applications. MagnTek' s products are not to be used in any device or system, including but not limited to medical life support equipment and system.

For the latest version of this document, please visit our website: [www.magntek.com.cn](http://www.magntek.com.cn)