

Ratiometric, Linear Hall-Effect IC, Analog Output with Magnet Temperature Shift Compensation

1 Product Description

The MT9106, MT9107, MT9108 and MT9109 series are linear Hall effect IC that responds proportionally to magnetic flux density. The device can be used for accurate position sensing in a wide range of applications.

The device operates from 3.0V to 5.5V power supplies. When no magnetic field is present, the analog output drives 1/2 of VCC. The output changes linearly with the applied magnetic flux density, and four sensitivity options enable maximal output voltage swing based on the required sensing range. North and south magnetic poles produce unique voltages.

The device also adjusts magnetic sensitivity with temperature to counteract how magnets naturally shift for linear performance from -40°C to 105°C.

The MT9106, MT9107, MT9108 and MT9109 series provides a variety of packages to customers. SOT-23 (Thin Outline) for surface mount and flat TO-92 for through-hole mount. All packages are RoHS compliant.

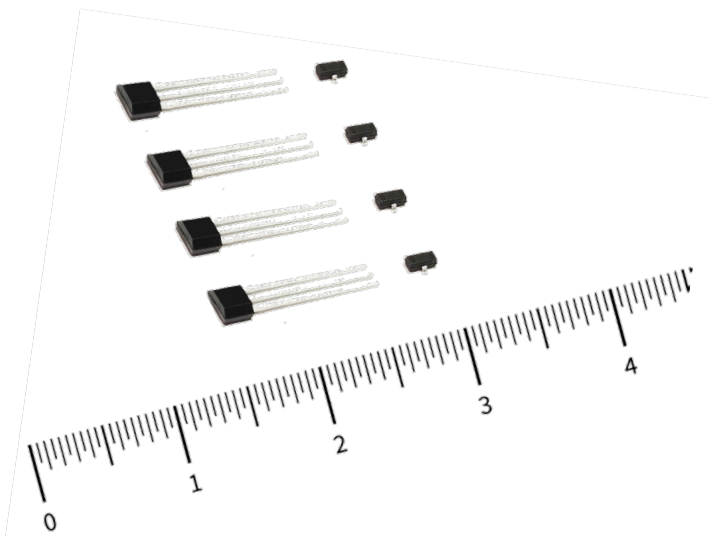

4 Product Overview of MT910x

Part No.	Description
MT910xA	Flat TO-92, bulk packaging (500pcs/bag)
MT910xET	SOT-23 (Thin Outline), tape & reel (3000pcs/bag)

2 Features

- BCD Technology
- AEC-Q100
- Factory-programmed
- Ratiometric Rail to Rail Analog Output
- Low-Noise Output
- Fast 30 kHz sensing bandwidth
- 3.0~5.5V Operating Vcc Range
- -40°C~150°C Operating Temperature
- Magnet temperature shift compensation
- Magnetic Sensitivity Option:
 - 1.50mV/Gs MT9106 Series @Vcc = 5V
 - 2.50mV/Gs MT9107 Series @Vcc = 5V
 - 3.40mV/Gs MT9108 Series @Vcc = 5V
 - 5.00mV/Gs MT9109 Series @Vcc = 5V
 - 1.00mV/Gs MT9106 Series @Vcc = 3.3V
 - 1.60mV/Gs MT9107 Series @Vcc = 3.3V
 - 2.15mV/Gs MT9108 Series @Vcc = 3.3V
 - 3.15mV/Gs MT9109 Series @Vcc = 3.3V
- Package Option:
 - Flat TO-92S
 - SOT-23 (thin Outline)
- RoHS Compliant: (EU)2015/863

3 Applications

- Home Appliances
- Automotive
- Industrial
- Position Detection
- Magnetic Encoder
- Ferrous Metal Sensing
- Vibration Sensing
- Weight Sensing
- Pan&Tilt
- Joystick

Table of Contents

1	Product Description.....	1
2	Features.....	1
3	Applications.....	1
4	Product Overview of MT910x	1
5	Pin Configuration and Functions.....	3
6	Transfer Characteristics.....	3
7	Function Description.....	4
8	Feature Description.....	4
9	Typical Application Circuit.....	4
10	Functional Block Diagram	5
11	Electrical and Magnetic Characteristics.....	5
	11.1 Absolute Maximum Ratings.....	5
	11.2 ESD Ratings.....	5
	11.3 Electrical Specifications.....	6
	11.4 Accuracy Characteristics.....	7
	11.5 Magnetic Characteristics.....	7
12	Package Material Information.....	8
	12.1 SOT-23 (Thin Outline) Package Information.....	8
	12.2 Flat TO-92 Package Information.....	9
13	Copy Rights and Disclaimer.....	10

Reversion History

1	Originally Version	
2	Version 1.0	Update the distance from the hall plate to the surface of the package & Ts & logo
3	Version 1.1	Add TRESP、TR、TPD
4	Version 1.2	Update the TA range and add AEC-Q100 identification; Update the drawing information of flat TO-92

5. Pin Configuration and Functions

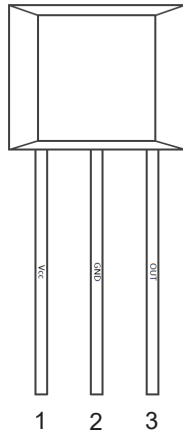

TO-92S
Top-View

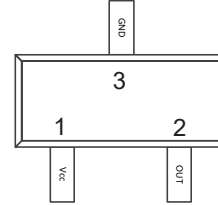

SOT-23
Thin Outline
Top-View

Figure.1 Pin Configuration & Functions

	VCC	OUT	GND
SOT-23 (Thin Outline)	1	2	3
Flat TO-92	1	3	2
Description	Power	Output	Ground

6 Transfer Characteristics

Figure.2&3 show four sensitivity options enable maximal output voltage swing based on the required sensing range

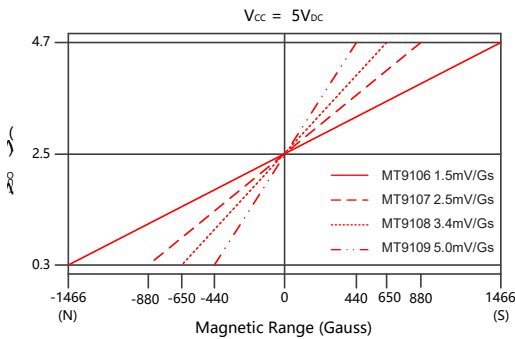

Figure.2 Transfer Characteristics (Vcc=5V)

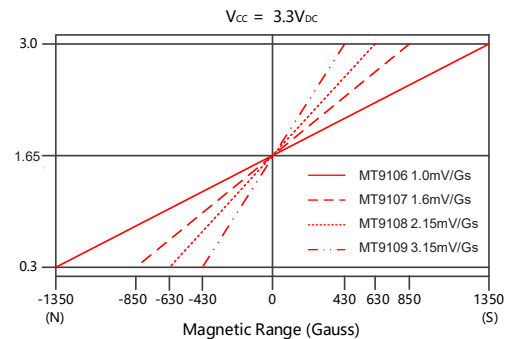

Figure.3 Transfer Characteristics (Vcc=3.3V)

7 Function Description

The device produces a linear response when the output voltage is within the specified voltage range. Outside this range, sensitivity is reduced and nonlinear

8 Feature Description

The MT9106, MT9107, MT9108 and MT9109 series are sensitive to the magnetic field component that are perpendicular to the top of the package

When the magnetic field moving from the left side of the IC to the middle which showed in the left of the Figure.3, the VOUT changing from 0.3 to 2.5V linearity when VCC=5V

When the magnetic field located at the middle of the IC which showed in the middle of the Figure.3, the VOUT is 2.5V (1/2 of the VCC=5V)

When the magnetic field moving from the middle side of the IC to the right which showed in the right of the Figure.3, the VOUT changing from 2.5 to 4.7V linearity when VCC=5V

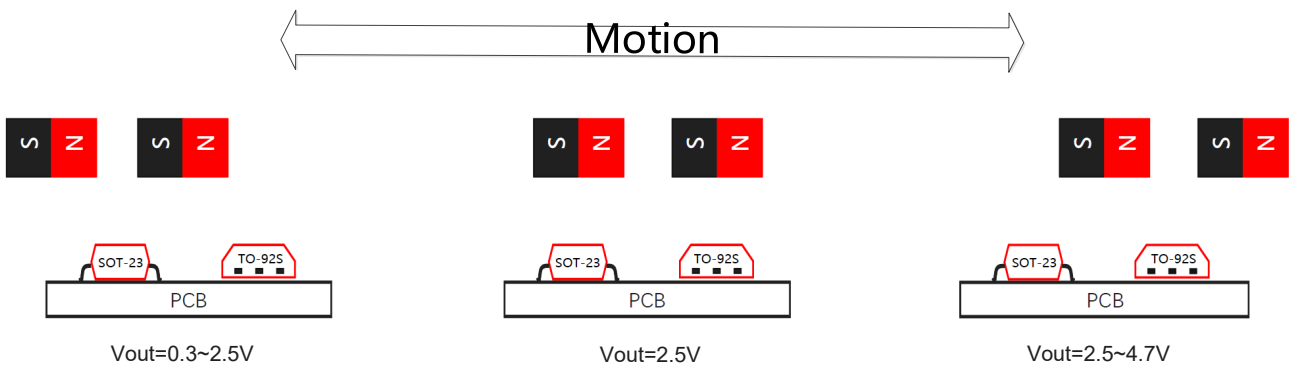

Figure.4 Feature Description

9 Typical Application Circuit

MT9106ET as example

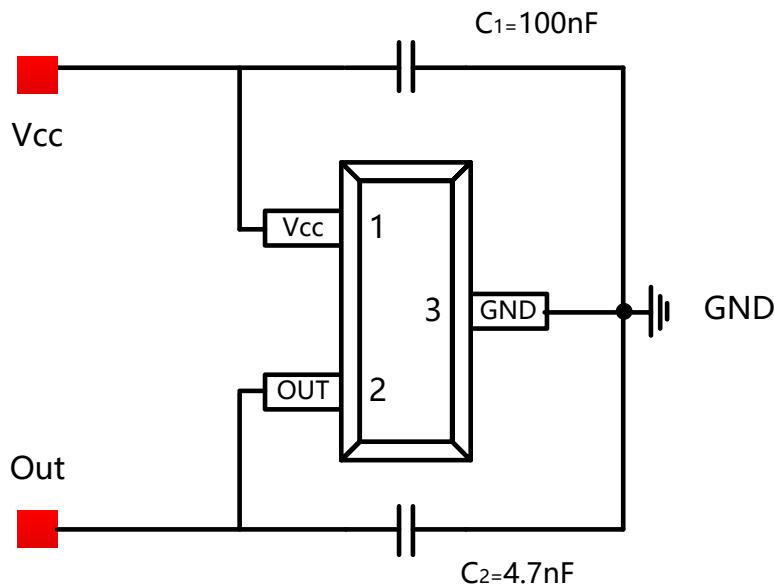

Figure.5 Typical Application Circuit

10 Functional Block Diagram

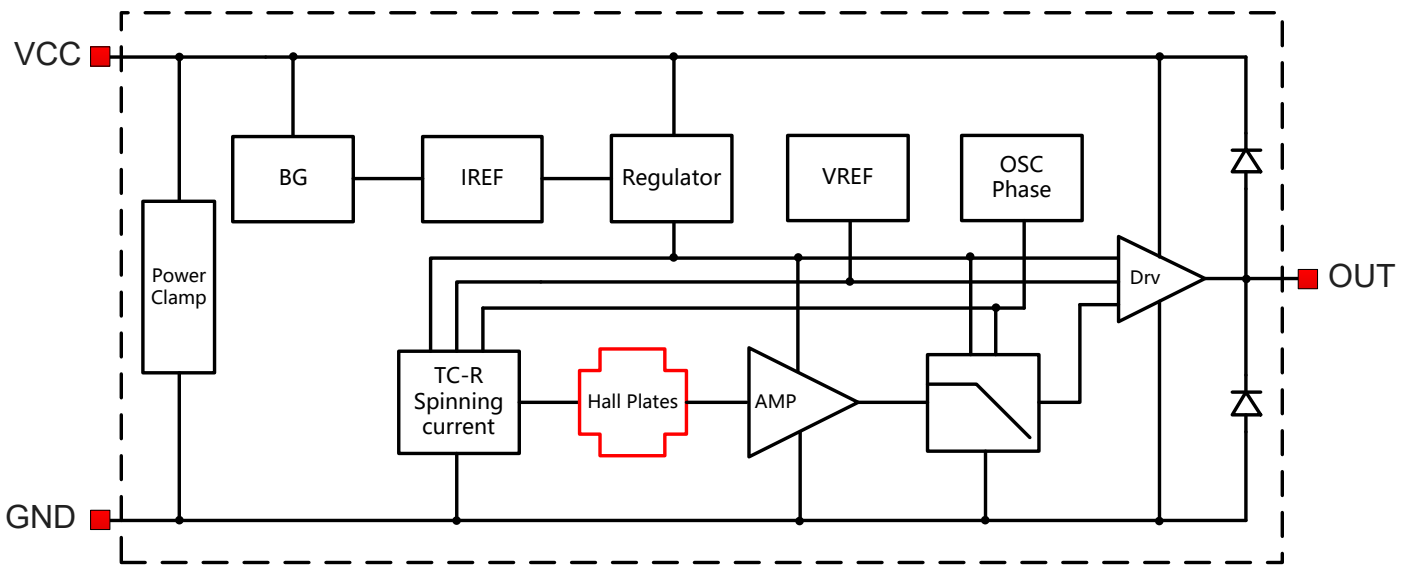

Figure.6 Functional Block Diagram

11 Electrical and Magnetic Characteristics

11.1 Absolute Maximum Ratings

Absolute maximum ratings are limited values to be applied individually, and beyond which the serviceability of the circuit may be impaired. Functional operability is not necessarily implied. Exposure to absolute maximum rating conditions for an extended period of time may affect device reliability.

Symbol	Parameters	Min	Max	Units
VCC	Supply Voltage	-	30	V
VRCC	Reverse Battery Voltage	-0.2	-	V
VOUT	Output Voltage	-	30	V
IOUT	Continuous Output Current	-5	5	mA
TA	Operating Ambient Temperature	-40	150	°C
TS	Storage Temperature	-40	150	°C
TJ	Junction Temperature	-	165	°C

11.2 ESD Ratings

Symbol	Reference	Values	Unit
VESD	Human-body model (HBM)	±3000	V
	Charged-device model (CDM)	±1000	V

11.3 Electrical Specifications

At TA=-40~150 °C, Vcc=3.0V~5.5V (unless otherwise specified)

Symbol	Parameters	Test Condition	Min	Typ	Max	Unit
VCC	Supply Voltage		3.0	-	5.5	V
ICC	Supply Current	VCC=5V; B=0	-	6.7	8.6	mA
		VCC=3.3V; B=0	-	6.0	7.0	mA
TPO	Power on Time	dVCC/dt≥5V/us	-	-	30	us
ISINK	Sink Current	B=0; VOUT=VCC	-1.5	-	-	mA
ISOURCE	Source Current	B=0; VOUT=0	-	-	1.5	mA
BW	Bandwidth		20	30	-	KHz
FC	Chopper Frequency		-	780	-	KHz
TRESP	Response Time	TA=25°C	-	15	-	us
TR	Rise Time	TA=25°C	-	12	-	us
TPD	Propagation Delay	TA=25°C	-	5.5	-	us
IND	Noise Density	Input-referenced noise density; TA=25°C, B=0, CL=1nF	-	1.9	2.6	mG/√Hz
NF	Noise	MT9106; TA=25°C	-	1.46	-	mVRMS
		MT9107; TA=25°C	-	2.44	-	mVRMS
		MT9108; TA=25°C	-	3.32	-	mVRMS
		MT9109; TA=25°C	-	4.88	-	mVRMS
ROUT	Output Resistance	IOUT≤±1.5mA VOUT=2.5V	-	2	4	Ω
RL	Output Loading Resistance	IOUT≤1.5mA Output to GND or to VCC	4.7	-	-	KΩ
CL	Output Loading Capacitance	IOUT≤±1.5mA Output to GND	-	-	10	nF
RTH	Thermal Resistance	SOT-23 (Thin outline)	-	301	-	°C/W
		Flat TO-92	-	230	-	°C/W

11.4 Accuracy Specifications

At $T_A = -40 \sim 150$ °C, $V_{CC} = 3.0V \sim 5.5V$ (unless otherwise specified)

Symbol	Parameters	Test Condition	Min	Typ	Max	Unit
LIN	Linearity		-1.5	-	1.5	%
VoQ	Quiescent Voltage	$V_{CC} = 5V; B = 0;$ $T_A = 25^\circ C$	2.475	2.500	2.525	V
		$V_{CC} = 3.3V; B = 0;$ $T_A = 25^\circ C$	1.630	1.650	1.670	V
VoQ (V)	Ratiometry, V_{NULL}		-1.5	-	1.5	%
VoQ (T)	V_{NULL} Variation Over Temperature		-1.5	-	1.5	%
SNST (TC)	Temperature coefficient of Sensitivity	$-40^\circ C \sim 105^\circ C$	-	1260	-	ppm/°C

10.5 Magnetic Characteristics

At $T_A = -40 \sim 150$ °C, $V_{CC} = 3.0V \sim 5.5V$ (unless otherwise specified)

Symbol	Parameters	Test Condition	Min	Typ	Max	Unit
SNST	Sensitivity $T_A = 25^\circ C; V_{CC} = 5V$	MT9106	1.395	1.500	1.605	mV/Gs
		MT9107	2.325	2.500	2.675	mV/Gs
		MT9108	3.162	3.400	3.638	mV/Gs
		MT9109	4.650	5.000	5.350	mV/Gs
	Sensitivity $T_A = 25^\circ C; V_{CC} = 3.3V$	MT9106	0.900	1.000	1.100	mV/Gs
		MT9107	1.488	1.600	1.712	mV/Gs
		MT9108	2.000	2.150	2.300	mV/Gs
		MT9109	2.930	3.150	3.370	mV/Gs
B	Magnetic Field Range $T_A = 25^\circ C; V_{CC} = 5V$	MT9106	-	± 1466	-	Gs
		MT9107	-	± 880	-	Gs
		MT9108	-	± 650	-	Gs
		MT9109	-	± 440	-	Gs
	Magnetic Field Range $T_A = 25^\circ C; V_{CC} = 3.3V$	MT9106	-	± 1350	-	Gs
		MT9107	-	± 850	-	Gs
		MT9108	-	± 630	-	Gs
		MT9109	-	± 430	-	Gs

12 Package Material Information (For Reference Only – Not for Tooling Use)

12.1 SOT-23 (Thin Outline) Package Information

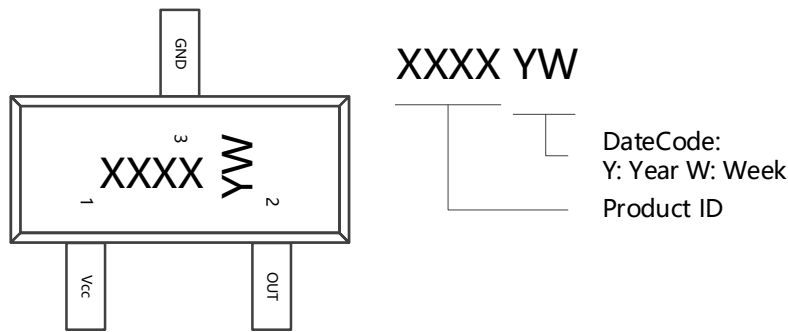

Figure.7 SOT-23 (Thin Outline) Chip Marking Spec

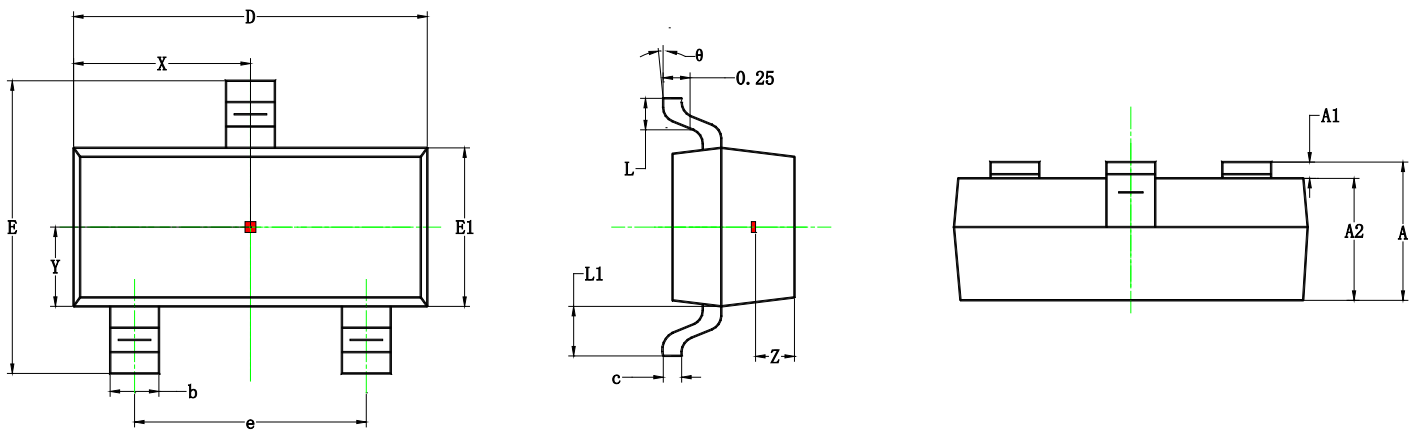

Figure.8 SOT-23 (Thin Outline) Package Drawing

Symbol	Dimensions in Millimeters		Dimensions in Inches	
	Min	Max	Min	Max
A	0.900	1.150	0.035	0.045
A1	0.000	0.100	0.000	0.004
A2	0.900	1.050	0.035	0.041
b	0.300	0.500	0.012	0.020
c	0.080	0.150	0.003	0.006
D	2.800	3.000	0.110	0.118
E	1.200	1.400	0.047	0.055
E1	2.250	2.550	0.089	0.100
e	0.950 TYP		0.037 TYP	
e1	1.800	2.000	0.071	0.079
L	0.550 REF		0.022 REF	
L1	0.300	0.500	0.012	0.020
θ	0 °	8 °	0 °	8 °
x	1.460 TYP		0.057 TYP	
y	0.650 TYP		0.026 TYP	
z	0.350 TYP		0.014 TYP	

12.2 Flat TO-92 Package Information

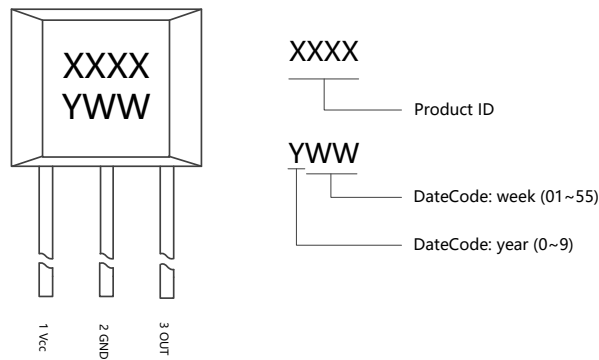

Figure.9 Flat TO-92 Chip Marking Spec

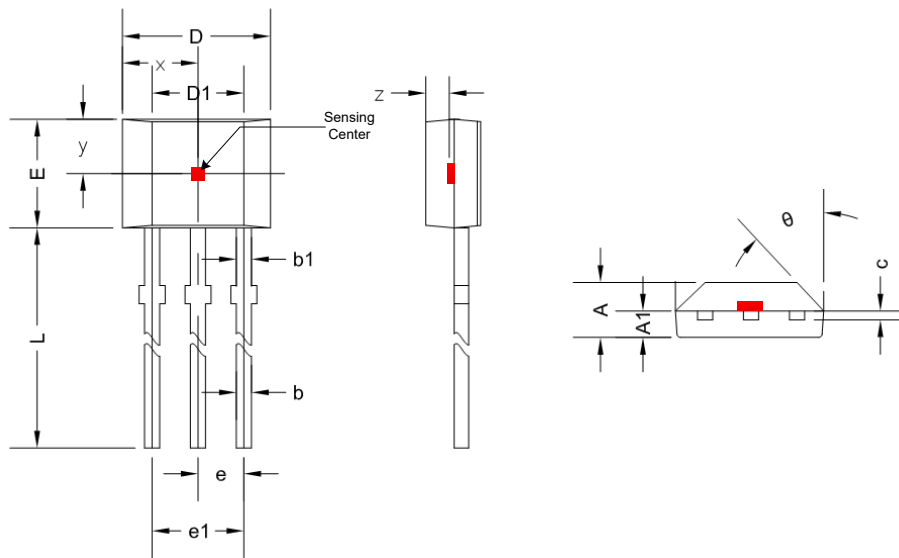

Figure.10 Flat TO-92 Package Drawing

Symbol	Dimensions in Millimeters		Dimensions in Inches	
	Min	Max	Min	Max
A	1.420	1.620	0.056	0.064
A1	0.660	0.860	0.026	0.034
b	0.330	0.480	0.013	0.019
b1	0.400	0.510	0.016	0.020
c	0.330	0.510	0.013	0.020
D	4.000	4.100	0.157	0.161
D1	2.280	2.680	0.090	0.106
E	3.050	3.250	0.120	0.128
e	1.270 TYP		0.050 TYP	
e1	2.440	2.640	0.096	0.104
L	14.350	14.750	0.565	0.580
θ	45 ° TYP		45 ° TYP	
x	2.000 TYP		0.079 TYP	
y	1.575 TYP		0.062 TYP	
z	0.440 TYP		0.017 TYP	

13 Copy Rights and Disclaimer

1. This document may not be reproduced or duplicated, in any form, in whole or in part without prior written consent of MagnTek . Copyrights © 2019, MagnTek Incorporated.
2. MagnTek reserves the right to make changes to the information published in this document at anytime without notice.
3. MagnTek's products are limited for use in normal commercial applications. MagnTek's products are not to be used in any device or system, including but not limited to medical life support equipment and system.

For the latest version of this document, please visit our website: www.magntek.com.cn