

Uni-polar, Nano Power Hall-Effect Switch IC

1 Product Description

The MT889X family is produced with CMOS technology. The Hall IC internally includes high sensitivity horizontal hall plates, sleep/awake logics for mode control, a low-power on-chip oscillator, low noise analog signal chain with dynamic offset cancellation, hysteresis comparators and an output driver.

The product responds to North pole or South pole magnetic fields. The output will be turned on (Low) when the magnetic flux density (B) is larger than the operating point (BOP), and be turned off (High) when the magnetic flux density (B) is lower than the releasing point (BRP).

The MT889X family provides a variety of packages to customers: DFN & SOT-23 for surface mount and flat TO-92 for through-hole mount. All packages are RoHS compliant.

2 Features

- CMOS Technology
- Uni-polar Switch
- 1.6 ~ 5V Operating Vcc Range
- -40°C ~ 85°C Operating Temperature
- Package Option:
 - SOT-23
 - Flat TO-92
 - DFN1608
 - DFN1616
- Magnetic Sensitivity Option:
 - BOP=30Gs, BRP=20Gs
- Push Pull Output
- RoHS Compliant: (EU)2015/863

3 Product Overview of MT889X

Part No.	Description
MT8891A	Flat TO-92, bulk packaging (1000pcs/bag)
MT8891AT	SOT-23, tape & reel (3000pcs/bag)
MT8891DT-1608	DFN1608, tape & reel (10000pcs/bag)
MT8891DT-1616	DFN1616, tape & reel (3000pcs/bag)

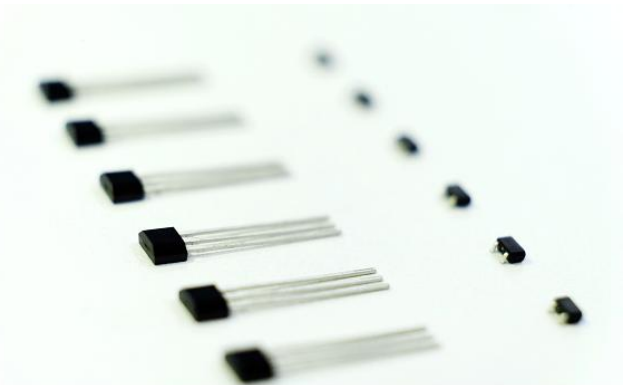

4 Applications

- Home appliances, Industrial
- Position Detection
- Solid-State Switch
- Proximity Switch
- Smart Meter
- Handheld Device
- Consumer Device

5. Pin Configuration and Functions

	Vcc	Out	GND
SOT-23	1	2	3
Flat TO-92	1	3	2
DFN1608	3	2	1
DFN1616	4	5	2
Description	Power	Output Push Pull	Ground

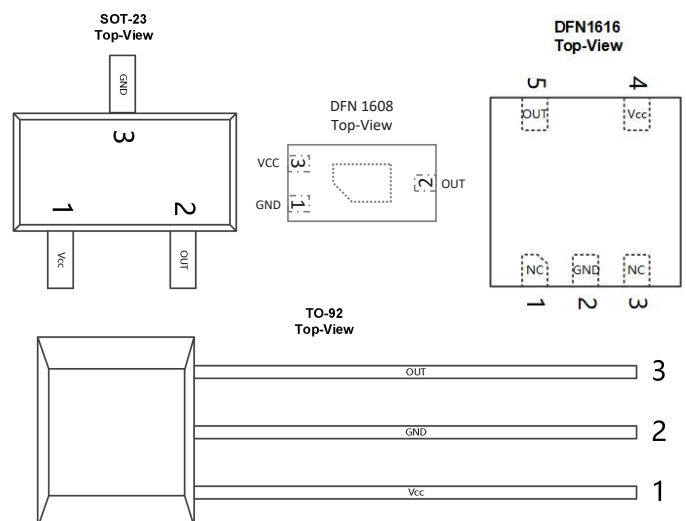

Figure.1 Pin Configuration & Functions

Table of Contents

1	Product Description.....	1
2	Features.....	1
3	Product Overview of MT889X	1
4	Applications.....	1
5	Pin Configuration and Functions.....	1
6	Definition of Switching Function.....	3
7	Function Description.....	3
8	Feature Description.....	3
9	Functional Block Diagram.....	4
10	Electrical and Magnetic Characteristics.....	4
	10.1 Absolute Maximum Ratings.....	4
	10.2 Electrical Specifications.....	5
	10.3 Magnetic Characteristics.....	5
	10.4 ESD Ratings.....	5
	10.5 Characteristic Performance.....	6
	10.6 Typical Output Waveform.....	7
11	Typical Application Circuit.....	7
12	Package Material Information.....	8
	12.1 SOT-23 Package Information.....	8
	12.2 Flat TO-92 Package Information.....	9
	12.3 DFN1608 Package Information.....	10
	12.4 DFN1616 Package Information.....	11
13	Copy Rights and Disclaimer.....	12

Reversion History

1	Originally Version	
2	1.1 Version	Update the Supply Voltage SPEC from 3.9V to 5V

6 Definition of Switching Function

Figure.2 & Figure.3 shows the device functionality and hysteresis

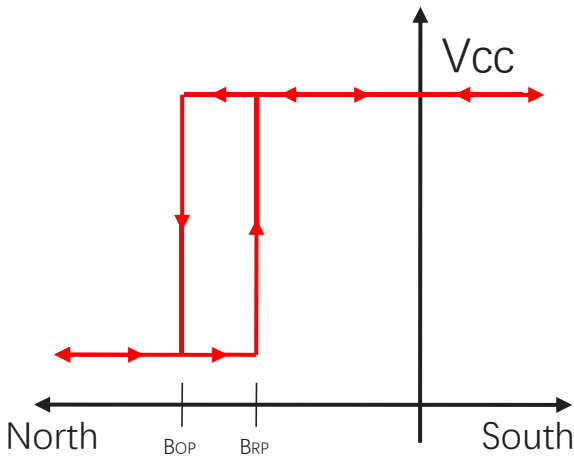

Figure.2 Switching Function Uni-polar (North)
SOT-23

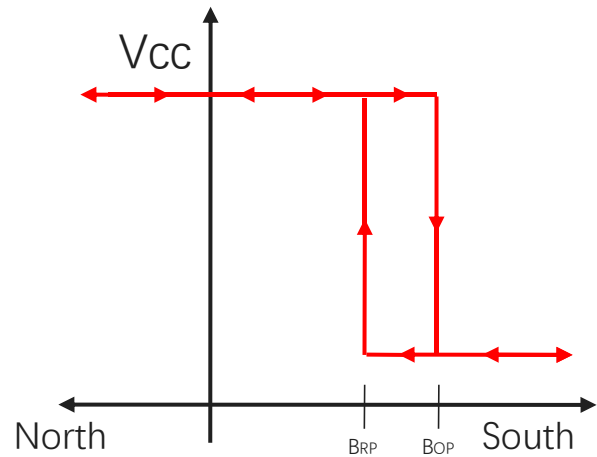

Figure.3 Switching Function Uni-polar (South)
Flat TO-92 / DFN1608 / DFN1616

7 Function Description

B_{OP}: Operating Point, Magnetic flux density applied on the branded side of the package which turns the output driver ON ($V_{OUT}=Low$)

B_{RP}: Releasing Point, Magnetic flux density applied on the branded side of the package which turns the output driver OFF ($V_{OUT}=High$)

B_{HYST}: Hysteresis Window, $|B_{OP} - B_{RP}|$

Devices that have a lower magnetic threshold ($V_{OUT}=High$) detect magnets at a farther distance. Higher thresholds ($V_{OUT}=Low$) generally require a closer distance or larger magnet.

8 Feature Description

The MT889X device is sensitive to the magnetic field component that is perpendicular to the top of the package

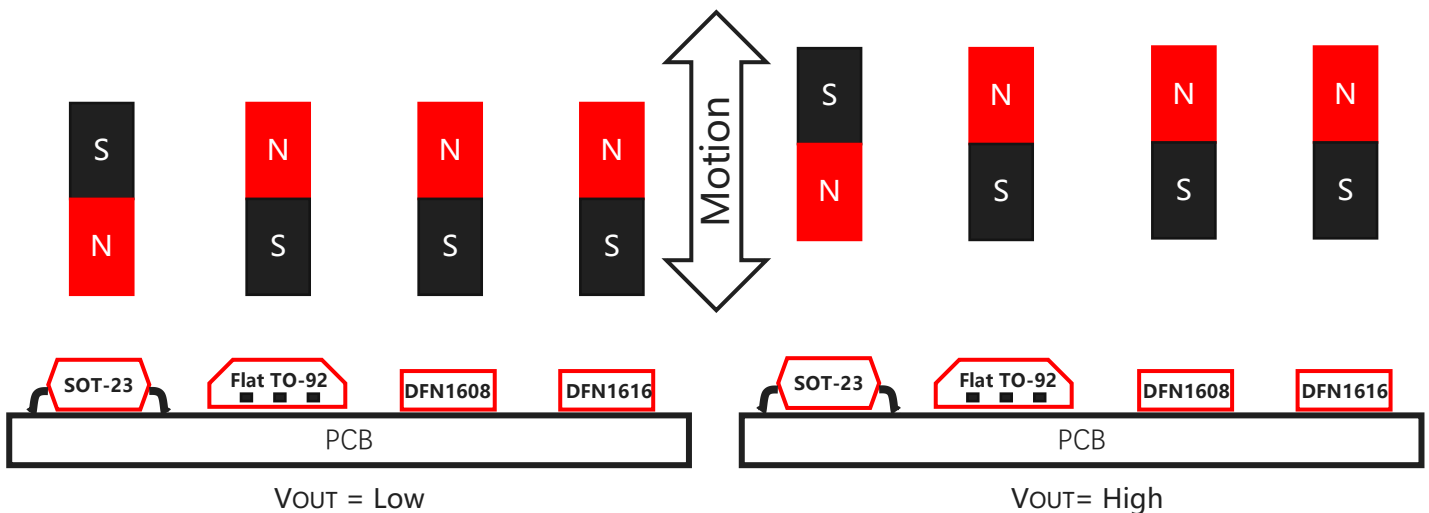

Figure.4 Flux Direction Polarity

9 Functional Block Diagram

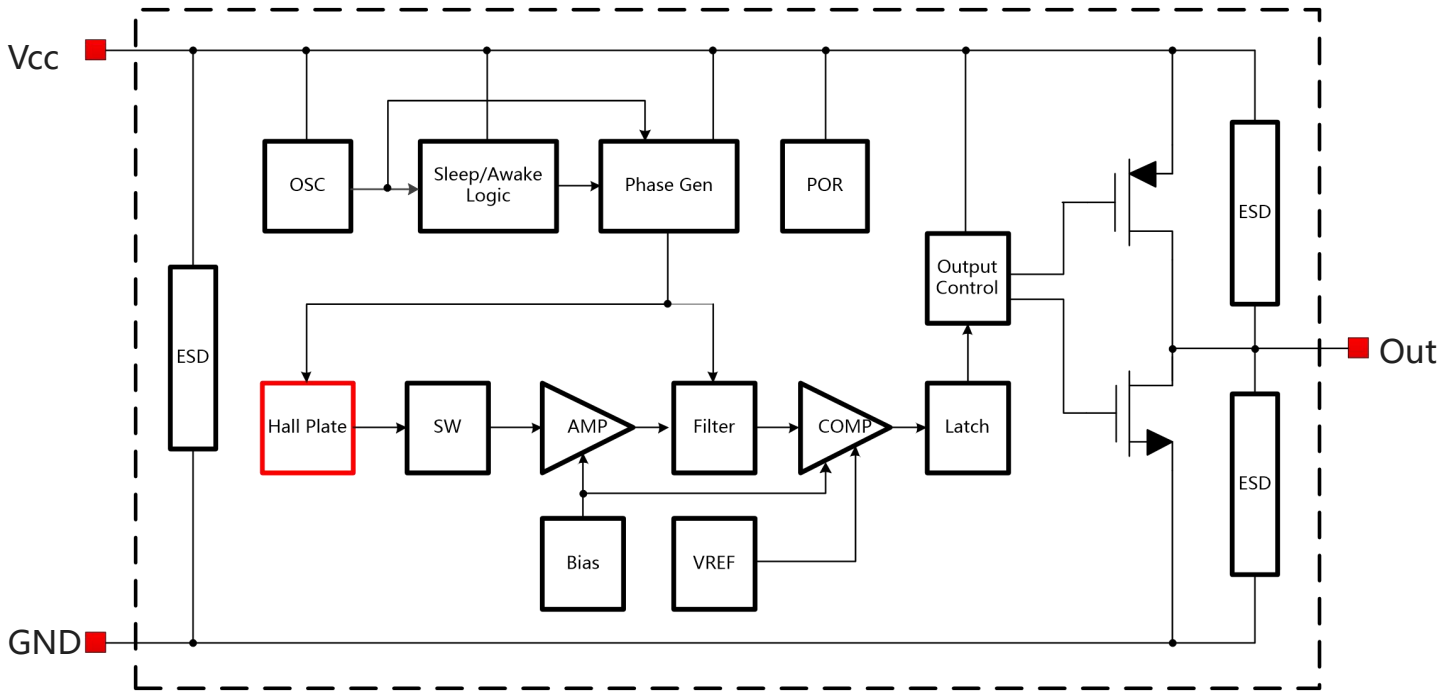

Figure.5 Functional Block Diagram

10 Electrical and Magnetic Characteristics

10.1 Absolute Maximum Ratings

Absolute maximum ratings are limited values to be applied individually, and beyond which the serviceability of the circuit may be impaired. Functional operability is not necessarily implied. Exposure to absolute maximum rating conditions for an extended period of time may affect device reliability.

Symbol	Parameters	Min	Max	Units
VCC	Supply Voltage	-	7	V
VRCC	Reverse Battery Voltage	-0.5	-	V
VOUT	Output Voltage	-	7	V
IOUT	Continuous Output Current	-	3	mA
TA	Operating Ambient Temperature	-40	85	°C
TS	Storage Temperature	-50	150	°C
TJ	Junction Temperature	-	165	°C
B	Magnetic Flux Density	No Limit		Gs

10.2 Electrical Specifications

At $T_A = -40 \sim 85^\circ\text{C}$, $V_{CC} = 1.6\text{V} \sim 5\text{V}$ (unless otherwise specified)

Symbol	Parameters	Test Condition	Min	Typ	Max	Unit
V_{CC}	Supply Voltage	Operating	1.6	-	5	V
I_{CC}	Supply Current	$V_{CC} = 3.3\text{V}$	-	1.7	-	μA
		$V_{CC} = 1.6\text{V}$	-	1.0	-	μA
I_{AW}	Awake Current	$V_{CC} = 3.3\text{V}$	-	2.5	-	mA
I_{SL}	Sleep Current	$V_{CC} = 3.3\text{V}$	-	1.0	-	μA
V_{OL}	Output Low Voltage	$I_{OUT} = 1\text{mA}$, $ B > B_{OP} $	-	-	0.4	V
V_{OH}	Output High Voltage	$I_{OUT} = 1\text{mA}$, $ B < B_{RP} $	$V_{CC} - 0.4$	-	-	V
F_{SW}	Switching Frequency	$V_{CC} = 3.3\text{V}$	10	20	40	Hz
T_{AW}	Awake Time	$V_{CC} = 1.6\text{V}$ to 5V	6	10	24	μs
T_{SL}	Sleep Time	$V_{CC} = 1.6\text{V}$ to 5V	25	50	105	ms
D.C.	Duty Cycle	$V_{CC} = 1.6\text{V}$ to 5V	-	0.02	-	%
T_{PO}	Power on Time	$dV_{CC}/dt > 5\text{V}/\mu\text{s}$, $ B > B_{OP} $	-	-	120	μs
R_{TH}	Thermal Resistance of SOT-23		-	301	-	$^\circ\text{C}/\text{W}$
	Thermal Resistance of DFN		-	301	-	$^\circ\text{C}/\text{W}$
	Thermal Resistance of Flat TO-92		-	230	-	$^\circ\text{C}/\text{W}$

10.3 Magnetic Characteristics

At $V_{CC} = 1.6\text{V} \sim 5\text{V}$ (unless otherwise specified)

Part No.	Symbol	Min	Typ	Max	Unit
MT8891 Series	B_{OP} , $T_A = 25^\circ\text{C}$	20	30	40	Gs
	B_{RP} , $T_A = 25^\circ\text{C}$	10	20	30	Gs
	B_{HYST} , $T_A = 25^\circ\text{C}$	-	10	-	Gs

10.4 ESD Ratings

Symbol	Reference	Values	Unit	
V_{ESD}	Human-body model (HBM)	AEC-Q100-002	± 5000	V
	Charged-device model (CDM)	AEC-Q100-011	± 1000	V

10.5 Characteristic Performance

At $V_{CC}=3.3V$

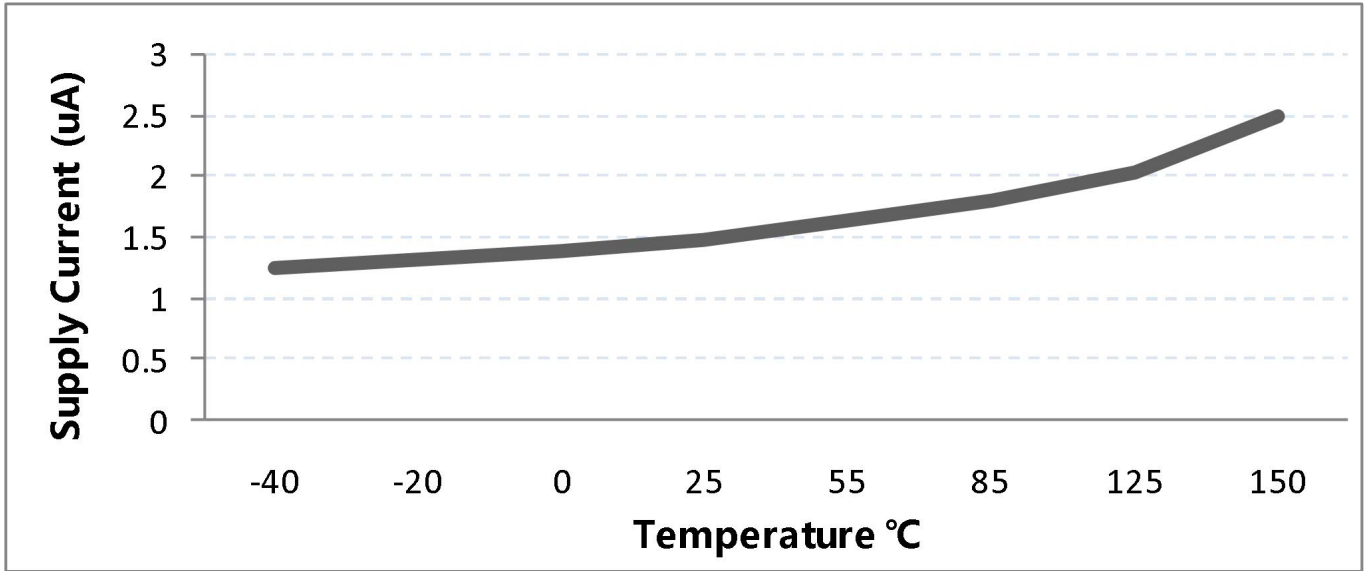

Figure.6 Supply Current vs. Temperature

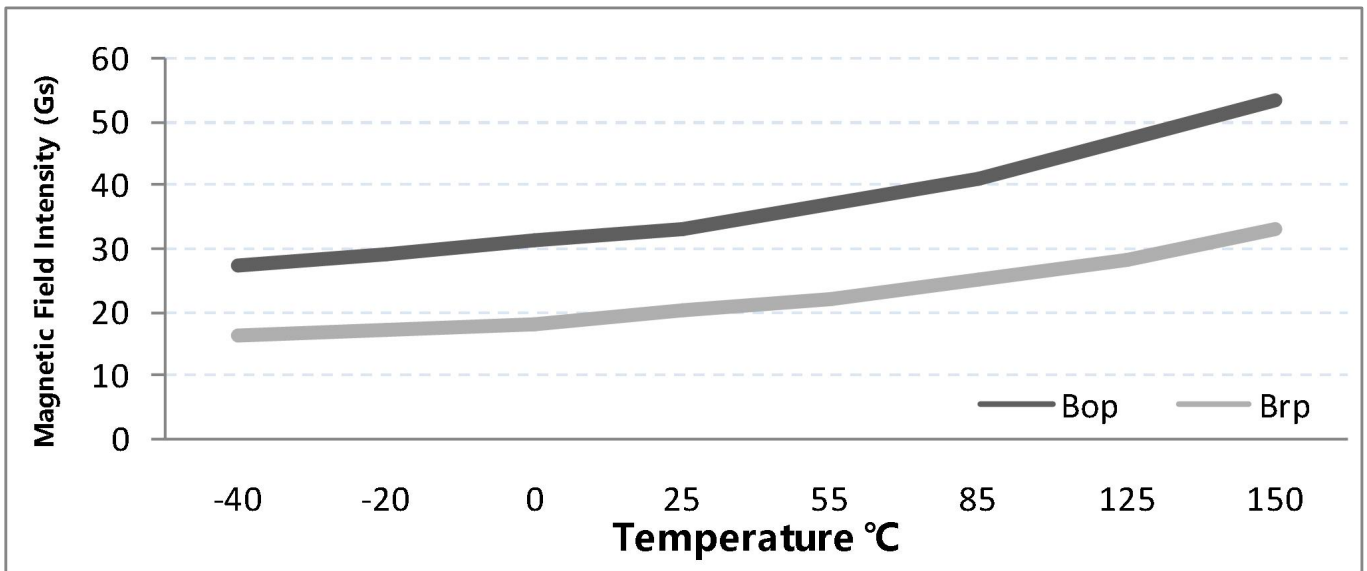

Figure.7 Magnetic Characteristics vs. Temperature (BOP & BRP)

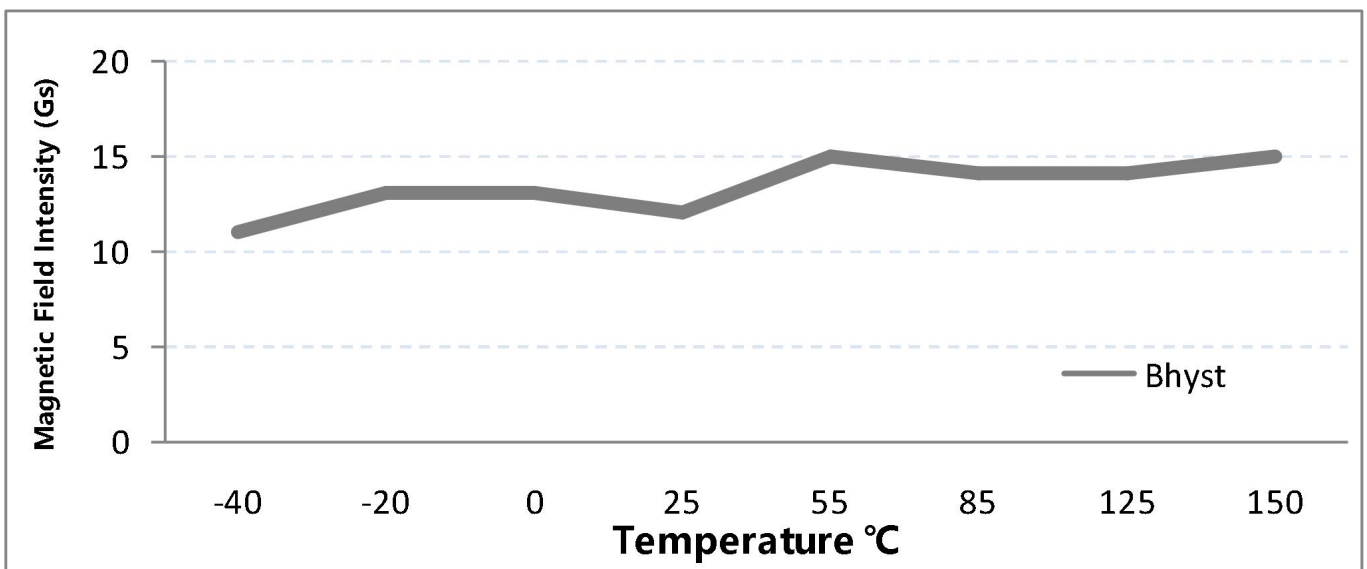

Figure.8 Magnetic Characteristics vs. Temperature (BHYST)

10.6 Typical Output Waveform

MT8891A as example

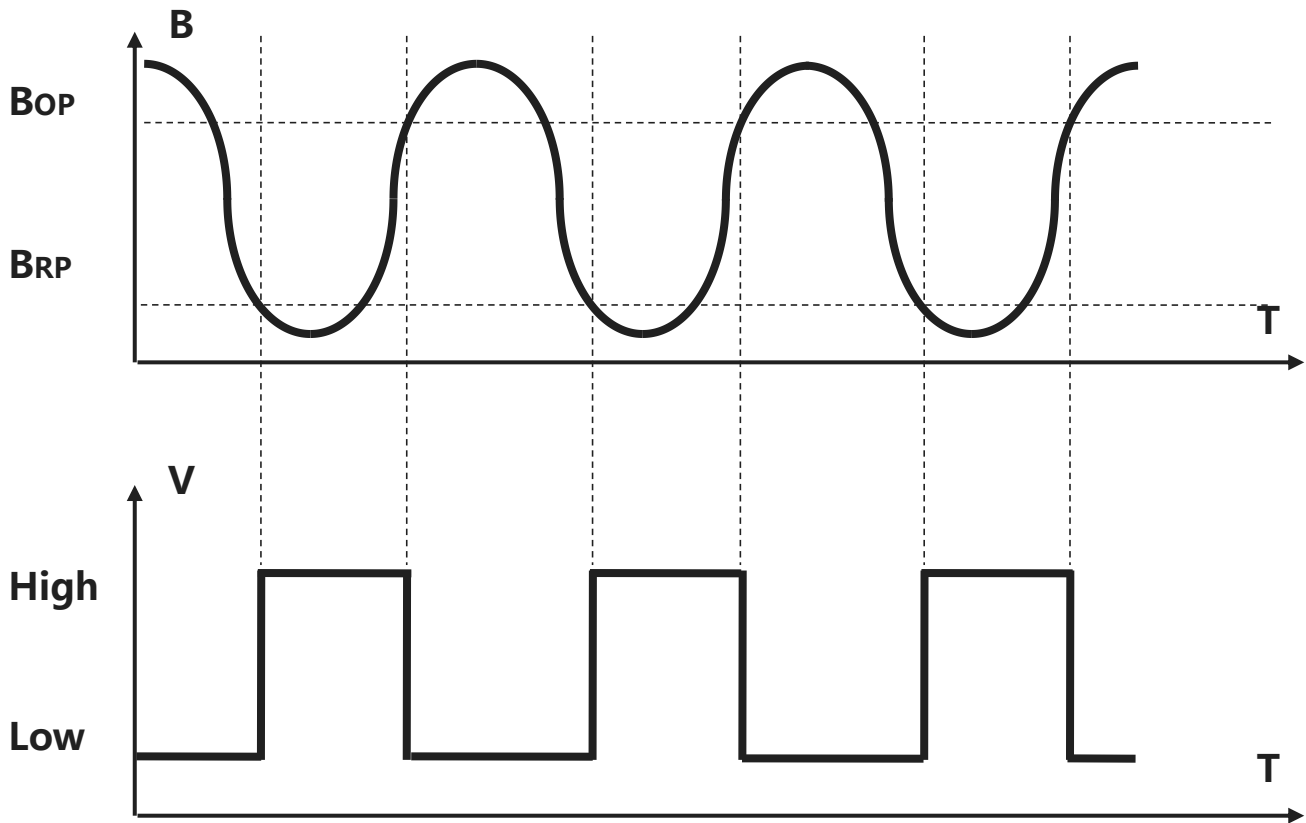

Figure.9 Digital Output vs. Magnetic Flux Density

11 Typical Application Circuit

MT8891AT as example

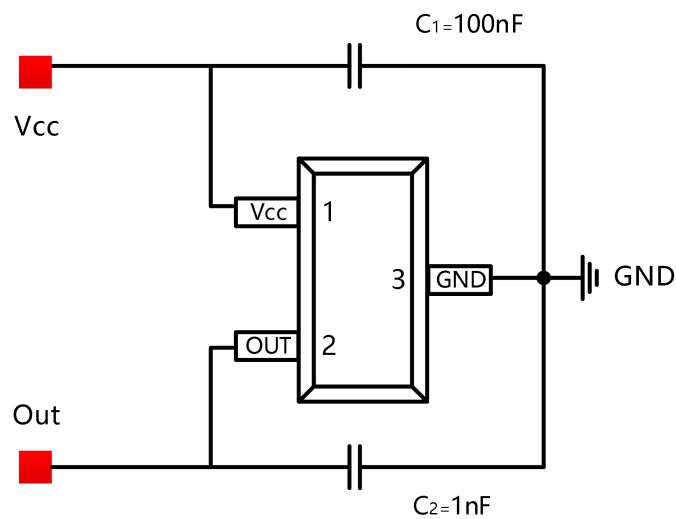

Figure.10 Typical Application Circuit

12 Package Material Information (For Reference Only – Not for Tooling Use)

12.1 SOT-23 Package Information

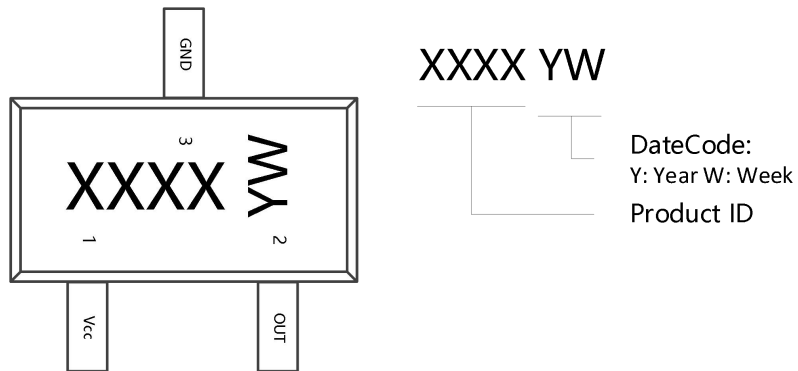

Figure.11 SOT-23 Chip Marking Spec

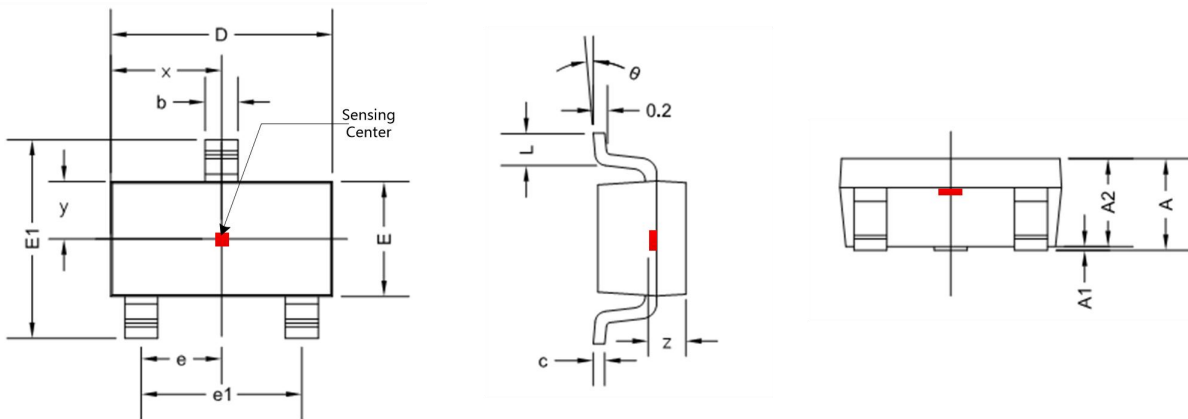

Figure.12 SOT-23 Package Drawing

Symbol	Dimensions in Millimeters		Dimensions in Inches	
	Min	Max	Min	Max
A	1.050	1.300	0.041	0.051
A1	0.000	0.150	0.000	0.006
A2	1.000	1.200	0.039	0.047
b	0.300	0.500	0.012	0.020
c	0.080	0.220	0.003	0.009
D	2.800	3.020	0.110	0.119
E	1.500	1.700	0.059	0.067
E1	2.600	3.000	0.102	0.118
e	0.950 TYP		0.037 TYP	
e1	1.800	2.000	0.071	0.079
L	0.300	0.600	0.012	0.024
θ	0 °	8 °	0 °	8 °
x	1.460 TYP		0.057 TYP	
y	0.800 TYP		0.032 TYP	
z	0.600 TYP		0.024 TYP	

12.2 Flat TO-92 Package Information

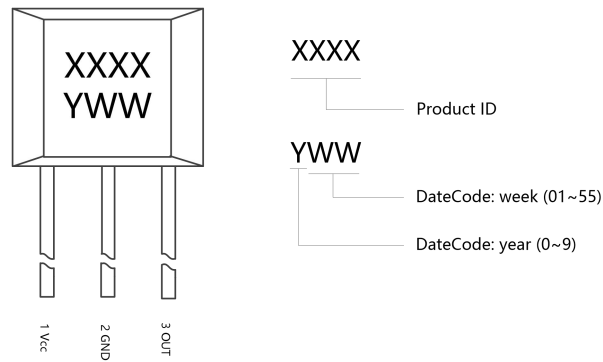

Figure.13 Flat TO-92 Chip Marking Spec

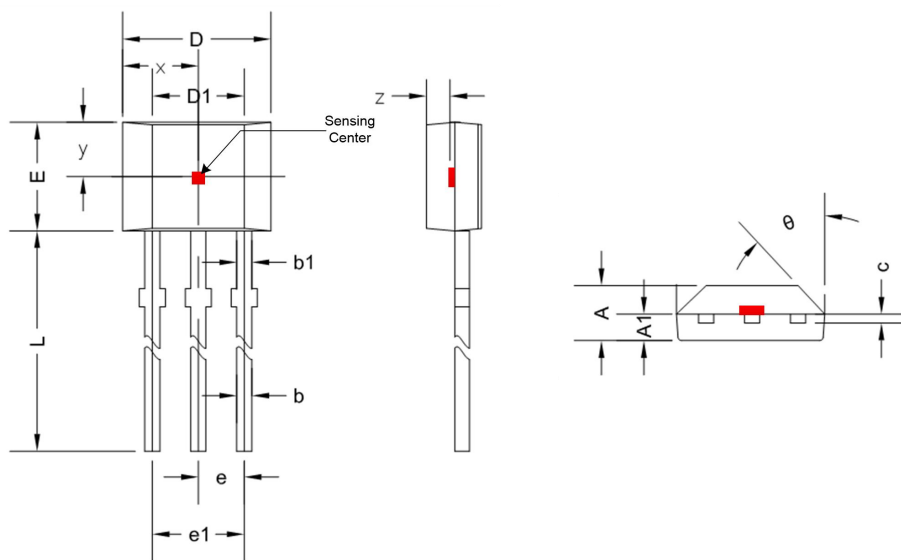
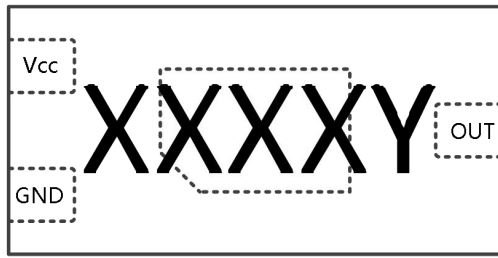

Figure.14 Flat TO-92 Package Drawing

Symbol	Dimensions in Millimeters		Dimensions in Inches	
	Min	Max	Min	Max
A	1.420	1.620	0.056	0.064
A1	0.660	0.910	0.026	0.036
b	0.330	0.560	0.013	0.022
b1	0.400	0.510	0.016	0.020
c	0.330	0.510	0.013	0.020
D	3.900	4.200	0.154	0.165
D1	2.280	2.680	0.090	0.106
E	2.900	3.280	0.114	0.128
e	1.270 TYP		0.050 TYP	
e1	2.440	2.640	0.096	0.104
L	13.500	16.200	0.531	0.638
θ	45 ° TYP		45 ° TYP	
x	2.025 TYP		0.080 TYP	
y	1.545 TYP		0.061 TYP	
z	0.500 TYP		0.020 TYP	

12.3 DFN1608 Package Information



XXXX Y

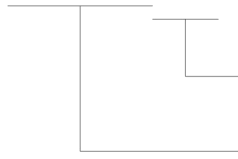

DateCode: week (A~z)
Product ID

Figure.15 DFN1608 Chip Marking Spec

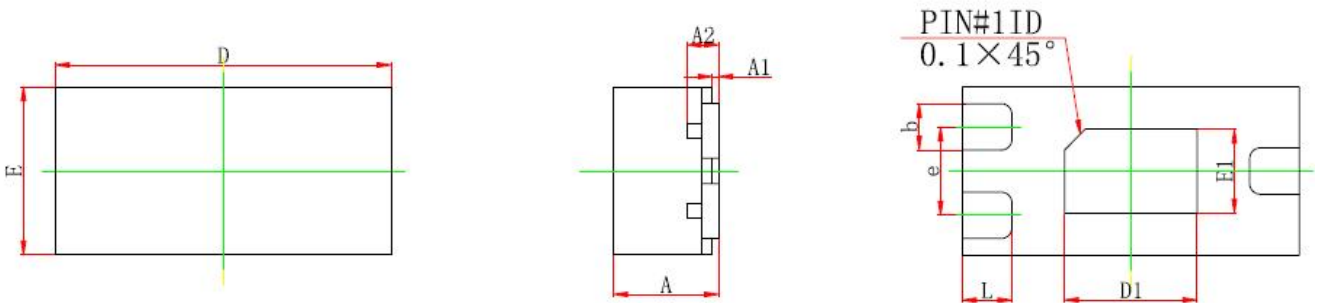

Figure.16 DFN1608 Package Drawing

Symbol	Dimensions in Millimeters		Dimensions in Inches	
	Min	Max	Min	Max
A	0.450	0.550	0.018	0.022
A1	0.000	0.050	0.000	0.002
A2	0.150 TYP		0.006 TYP	
D	1.550	1.650	0.061	0.065
E	0.750	0.850	0.030	0.033
D1	0.580	0.680	0.023	0.027
E1	0.350	0.450	0.014	0.018
b	0.170	0.270	0.007	0.011
e	0.420 TYP		0.017 TYP	
L	0.185	0.285	0.007	0.011

12.4 DFN1616 Package Information

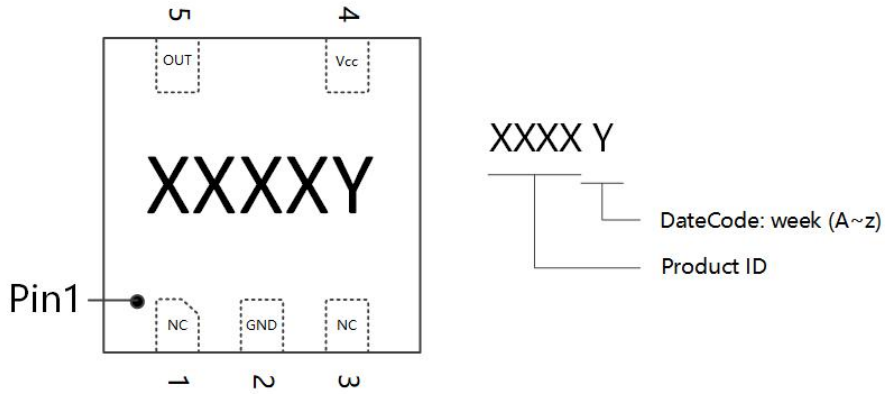

Figure.17 DFN1616 Chip Marking Spec

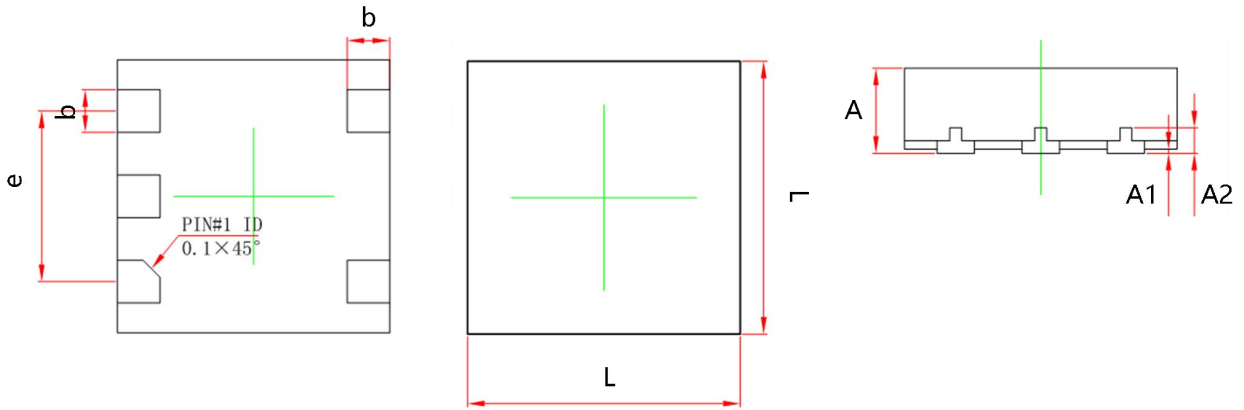

Figure.18 DFN1616 Package Drawing

Symbol	Dimensions in Millimeters		Dimensions in Inches	
	Min	Max	Min	Max
A	0.450	0.550	0.018	0.022
A1	0.000	0.050	0.000	0.002
A2	0.150 TYP		0.006 TYP	
L	1.550	1.650	0.061	0.065
b	0.200	0.300	0.008	0.012
e	1.000 TYP		0.039 TYP	

13 Copy Rights and Disclaimer

1. This document may not be reproduced or duplicated, in any form, in whole or in part without prior written consent of MagnTek . Copyrights © 2019, MagnTek Incorporated.
2. MagnTek reserves the right to make changes to the information published in this document at anytime without notice.
3. MagnTek' s products are limited for use in normal commercial applications. MagnTek' s products are not to be used in any device or system, including but not limited to medical life support equipment and system.

For the latest version of this document, please visit our website: www.magntek.com.cn