

Product Overview

The NST86-Q1SCR is a high-precision CMOS analogue output temperature sensor, designed to provide accurate readings in a wide range of applications. The device offers maximum accuracy of $\pm 1.5\text{ }^{\circ}\text{C}$ at $25\text{ }^{\circ}\text{C}$, with a maximum of $\pm 2.5\text{ }^{\circ}\text{C}$ across the full temperature range. The device is specified for use across the full temperature range of $-50\text{ }^{\circ}\text{C}$ to $150\text{ }^{\circ}\text{C}$, with a power supply operating range of 2.7V to 5.5V. However, the minimum operating voltage can be as low as 2.4V when the temperature range is $-30\text{ }^{\circ}\text{C}$ to $150\text{ }^{\circ}\text{C}$.

The NST86-Q1SCR device provides a negative slope output of $-10.9\text{mV}/^{\circ}\text{C}$ over the temperature range of $-30\text{ }^{\circ}\text{C}$ to $100\text{ }^{\circ}\text{C}$. It offers high linearity, eliminating the need for complex calculations or lookup tables to derive temperature.

The NST86-Q1SCR is a low-power temperature sensor with an operating current of just $19\text{ }\mu\text{A}$, resulting in negligible self-heating of the device. The NST86-Q1SCR is available in a SC70 package and is suitable for a variety of automotive applications, including electric power steering, gearshift systems, battery management systems, and automotive audio mainframes.

Key Features

- Operating Voltage Range: 2.4V to 5.5V
- Operating Temperature Range: $-50\text{ }^{\circ}\text{C}$ to $150\text{ }^{\circ}\text{C}$
- AEC-Q100 Grade1 Qualified
- Accuracy at $25\text{ }^{\circ}\text{C}$: $\pm 1.5\text{ }^{\circ}\text{C}$ (Maximum)
- Accuracy at $-50\text{ }^{\circ}\text{C}$ to $150\text{ }^{\circ}\text{C}$: $\pm 2.5\text{ }^{\circ}\text{C}$ (Maximum)
- Average Sensor Gain: $-10.9\text{mV}/^{\circ}\text{C}$
- Output Impedance: 1Ω (Typical)
- Operating Current: $19\text{ }\mu\text{A}$ (Typical)
- Push-Pull Output Current Drain: $500\text{ }\mu\text{A}$ (Maximum)
- Predictable Curvature Error
- Output Short Protection

- Suitable for Remote Applications
- Package: SC70(5)
- ROHS Compliance for SC70(5)

Applications

- Electric Power Steering
- Power Supply Modules
- Gearshift Systems
- Battery Management Systems
- Automotive Audio Mainframes

Device Information

Part Number	Package	Body Size
NST86-Q1SCR	SC70(5)	2.00mm × 1.25mm

Functional Block Diagram

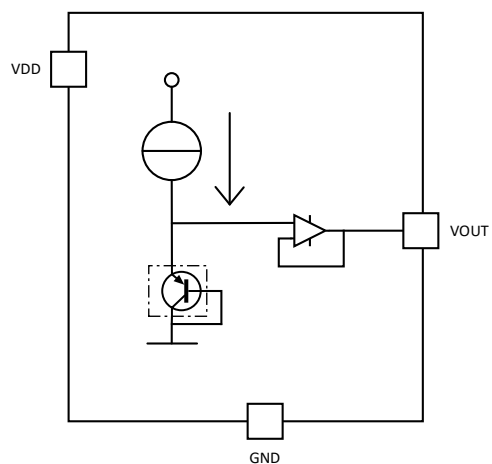

Figure 1. NST86-Q1SCR Block Diagram

INDEX

1. PIN CONFIGURATION AND FUNCTIONS3

2. ABSOLUTE MAXIMUM RATINGS4

3. ESD RATINGS.....4

4. SPECIFICATIONS5

 4.1. ELECTRICAL CHARACTERISTICS 5

 4.2. TYPICAL CHARACTERISTICS6

5. FUNCTION DESCRIPTION7

 5.1. OVERVIEW7

 5.2. FUNCTIONAL BLOCK DIAGRAM7

 5.3. FEATURE DESCRIPTION7

 5.3.1. NST86-Q1SCR TRANSFER FUNCTION7

 5.3.2. APPLICATION CURVE.....10

6. APPLICATION INFORMATION 11

 6.1. CAPACITIVE LOADS..... 11

 6.2. TYPICAL APPLICATION 11

 6.3. SYSTEM EXAMPLES 12

 6.3.1. CONSERVING POWER DISSIPATION WITH SHUTDOWN12

 6.3.2. ANALOG-TO-DIGITAL CONVERTER INPUT STAGE12

7. PACKAGE INFORMATION.....13

 7.1. SC70 PACKAGE 13

 7.2. TAPE AND REEL INFORMATION 14

 7.3. LAND PATTERN 15

8. ORDER INFORMATION.....16

9. MARKING17

10. REVISION HISTORY18

1. Pin Configuration and Functions

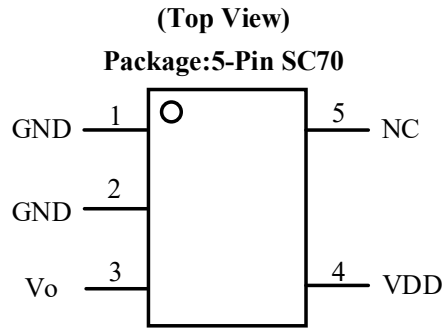

Figure 1.1 NST86-Q1SCR pin configuration

Table 1.1 NST86-Q1SCR Function Description

<i>Pin</i>		<i>Type</i>	<i>Description</i>
<i>No.</i>	<i>Name</i>		
1	GND	GND	Ground pin, connect to power supply negative terminal.
2	GND	GND	Ground pin, connect to power supply negative terminal. This pin must be grounded for optimum thermal conductivity.
3	Vo	Analog Output	Analog voltage output
4	VDD	Power	Power supply input pin
5	NC	-	No Connection

2. Absolute Maximum Ratings

<i>Parameters</i>	<i>Symbol</i>	<i>Min</i>	<i>Typ</i>	<i>Max</i>	<i>Unit</i>	<i>Comments</i>
Supply Voltage Pin (VDD)	VDD	-0.3		6.5	V	
Output Voltage	Vout	-0.3		VDD+0.3	V	
Storage Temperature		-60		155	°C	
Operation Temperature	T _{Boperation}	-50		150	°C	
Maximum Junction Temperature				155	°C	

3. ESD Ratings

	<i>Ratings</i>	<i>Value</i>	<i>Unit</i>
Electrostatic Discharge	Human body model (HBM), per AEC-Q100-002	±4.5	kV
	Charged device model (CDM), per AEC-Q100-011	±750	V

4. Specifications

4.1. Electrical Characteristics

All typical values at TA = +25°C and VDD = +3.3V, unless otherwise noted.

<i>Parameters</i>	<i>Symbol</i>	<i>Min</i>	<i>Typ</i>	<i>Max</i>	<i>Unit</i>	<i>Comments</i>
Supply						
Supply Voltage Range	VDD	2.4	3.3	5.5	V	
Supply Sensitivity			0.6		°C/V	
Operation Current	Iconv		19		µA	
Temperature Range						
Temperature Range		-50		150	°C	
Accuracy		-1.5	0.5	1.5	°C	at 25°C
		-2.5		2.5	°C	from -50°C to 150°C
Output Voltage at 0°C			2.1		V	
Vout Drive Capability				500	µA	
Sensor Gain			-10.9		mV/°C	
Output Impedance			1		Ω	
Thermal Response						
Stirred Oil Thermal Response Time to 63% of Final Value (Package Only)			0.53		s	
Drift						
Drift ¹			±0.03		°C	

Notes: 1. Drift data is based on a 1000-hour stress test at +150°C with VDD = 5.5V.

4.2. Typical Characteristics

at VDD = 3.3 V, unless otherwise noted.

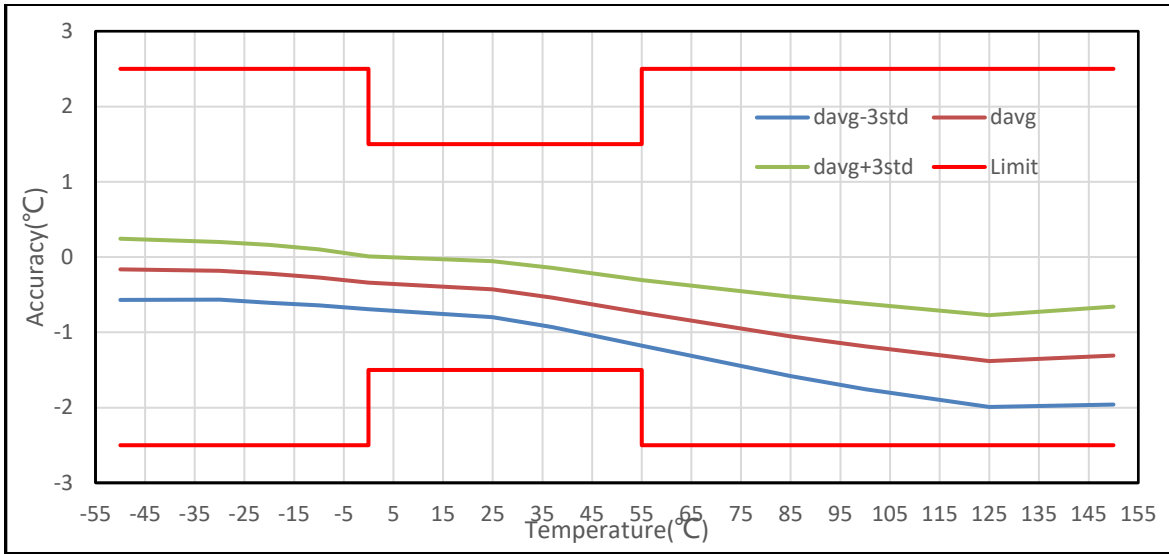

Figure 4.1 Temperature Error vs Temperature

5. Function Description

5.1. Overview

The NST86-Q1SCR is a high precision CMOS analog output temperature sensor. The device offers a maximum accuracy of $\pm 1.5^{\circ}\text{C}$ at 25°C and a maximum of $\pm 2.5^{\circ}\text{C}$ over the full temperature range. The device is specified at the full temperature range of -50°C to 150°C and the power supply operating range is 2.7V to 5.5V, however, the minimum operating voltage can be as low as 2.4V when the temperature range is -30°C to 150°C .

The NST86-Q1SCR device provides a negative slope output of $-10.9\text{mV}/^{\circ}\text{C}$ over -30°C to 100°C . it is highly linear and does not require complex calculations or lookup tables to derive temperature.

The NST86-Q1SCR is a low power device, and the typical operating current is $19\mu\text{A}$. Therefore, self-heating is negligible. The NST86-Q1SCR is available in a SC70(5) package, making it suitable for on-board and off-line applications in the industrial, and consumer markets applications in the IoT.

5.2. Functional Block Diagram

The NST86-Q1SCR Functional Block Diagram as shown in [Figure 5.1](#).

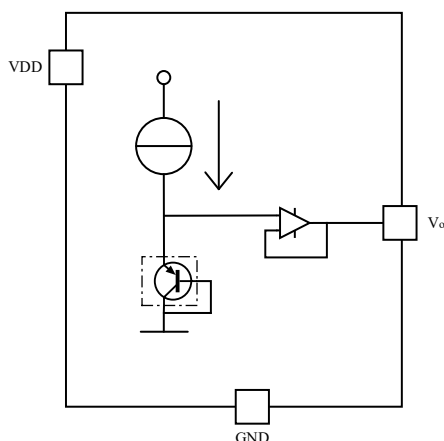

Figure 5.1 NST86-Q1SCR Functional Block Diagram

5.3. Feature Description

5.3.1. NST86-Q1SCR Transfer Function

The output voltage of NST86-Q1SCR over the entire operating temperature range as shown in [Table 5.1](#), and it is a reference table for determining the NST86-Q1SCR accuracy specifications (listed in the accuracy section of [Electrical Characteristics](#)).

Table 5.1 NST86-Q1SCR Temperature to Voltage Output Transfer Table

TEMP ($^{\circ}\text{C}$)	VOUT (mV)	TEMP ($^{\circ}\text{C}$)	VOUT (mV)	TEMP ($^{\circ}\text{C}$)	VOUT (mV)	TEMP ($^{\circ}\text{C}$)	VOUT (mV)	TEMP ($^{\circ}\text{C}$)	VOUT (mV)
-50	2616	-10	2207	30	1777	70	1335	110	883
-49	2607	-9	2197	31	1766	71	1324	111	872
-48	2598	-8	2186	32	1756	72	1313	112	860
-47	2589	-7	2175	33	1745	73	1301	113	849
-46	2580	-6	2164	34	1734	74	1290	114	837
-45	2571	-5	2154	35	1723	75	1279	115	826
-44	2562	-4	2143	36	1712	76	1268	116	814

TEMP (°C)	VOUT (mV)	TEMP (°C)	VOUT (mV)	TEMP (°C)	VOUT (mV)	TEMP (°C)	VOUT (mV)	TEMP (°C)	VOUT (mV)
-43	2553	-3	2132	37	1701	77	1257	117	803
-42	2543	-2	2122	38	1690	78	1245	118	791
-41	2533	-1	2111	39	1679	79	1234	119	780
-40	2522	0	2100	40	1668	80	1223	120	769
-39	2512	1	2089	41	1657	81	1212	121	757
-38	2501	2	2079	42	1646	82	1201	122	745
-37	2491	3	2068	43	1635	83	1189	123	734
-36	2481	4	2057	44	1624	84	1178	124	722
-35	2470	5	2047	45	1613	85	1167	125	711
-34	2460	6	2036	46	1602	86	1155	126	699
-33	2449	7	2025	47	1591	87	1144	127	688
-32	2439	8	2014	48	1580	88	1133	128	676
-31	2429	9	2004	49	1569	89	1122	129	665
-30	2418	10	1993	50	1558	90	1110	130	653
-29	2408	11	1982	51	1547	91	1099	131	642
-28	2397	12	1971	52	1536	92	1088	132	630
-27	2387	13	1961	53	1525	93	1076	133	618
-26	2376	14	1950	54	1514	94	1065	134	607
-25	2366	15	1939	55	1503	95	1054	135	595
-24	2355	16	1928	56	1492	96	1042	136	584
-23	2345	17	1918	57	1481	97	1031	137	572
-22	2334	18	1907	58	1470	98	1020	138	560
-21	2324	19	1896	59	1459	99	1008	139	549
-20	2313	20	1885	60	1448	100	997	140	537
-19	2302	21	1874	61	1436	101	986	141	525
-18	2292	22	1864	62	1425	102	974	142	514
-17	2281	23	1853	63	1414	103	963	143	502
-16	2271	24	1842	64	1403	104	951	144	490
-15	2260	25	1831	65	1391	105	940	145	479
-14	2250	26	1820	66	1380	106	929	146	467
-13	2239	27	1810	67	1369	107	917	147	455
-12	2228	28	1799	68	1358	108	906	148	443

TEMP (°C)	VOUT (mV)	TEMP (°C)	VOUT (mV)	TEMP (°C)	VOUT (mV)	TEMP (°C)	VOUT (mV)	TEMP (°C)	VOUT (mV)
-11	2218	29	1788	69	1346	109	895	149	432
-	-	-	-	-	-	-	-	150	420

As Table 5.1 show, although NST86-Q1SCR is highly linear, but there is still a small quadratic coefficient. The Transfer Table of NST86-Q1SCR can be calculated by using the parabolic equation (Equation 5-1).

$$V_{TEMP}(mV) = - \left[10.888 \frac{mV}{^{\circ}C} (T - 30^{\circ}C) \right] - \left[0.00347 \frac{mV}{^{\circ}C^2} (T - 30^{\circ}C)^2 \right] + 1777.3mV \quad (5-1)$$

The parabolic equation above is the approximate value of the transfer table. Under extreme temperature conditions, the temperature accuracy calculated by using this equation decreases slightly. The value of t can be solved by equation 5-2:

$$T = \frac{10.888 - \sqrt{(-10.888)^2 + 4 \times 0.00347 \times (1777.3 - V_{TEMP}(mV))}}{2 \times (-0.00347)} + 30 \quad (5-2)$$

In applications with low absolute accuracy requirements, the line can be easily calculated in a desired temperature range from a table using a two-point equation (Equation 5-3).

$$V - V_1 = (T - T_1) \times [(V_2 - V_1)/(T_2 - T_1)] \quad (5-3)$$

Where, the unit of V is mV, the unit of T is °C, T₁ and V₁ are the coordinates of the lowest temperature, and T₂ and V₂ are the coordinates of the highest temperature.

For instance, when users want to solve this equation for a temperature range of 30°C to 60°C, they would proceed as follows:

$$V - 1777mV = [(1448mV - 1777mV)/(60^{\circ}C - 30^{\circ}C)] \times (T - 30^{\circ}C) \quad (5-4)$$

$$V - 1777mV = (-10.9mV/^{\circ}C) \times (T - 30^{\circ}C) \quad (5-5)$$

$$V = (-10.9mV/^{\circ}C) \times T + 2103mV \quad (5-6)$$

Using this linear approximation method above, the transfer function can be approximated for one or more temperature ranges.

5.3.2.Application Curve

The NST86-Q1SCR is highly linear, and Output Voltage vs Temperature as shown in [Figure 5.2](#).

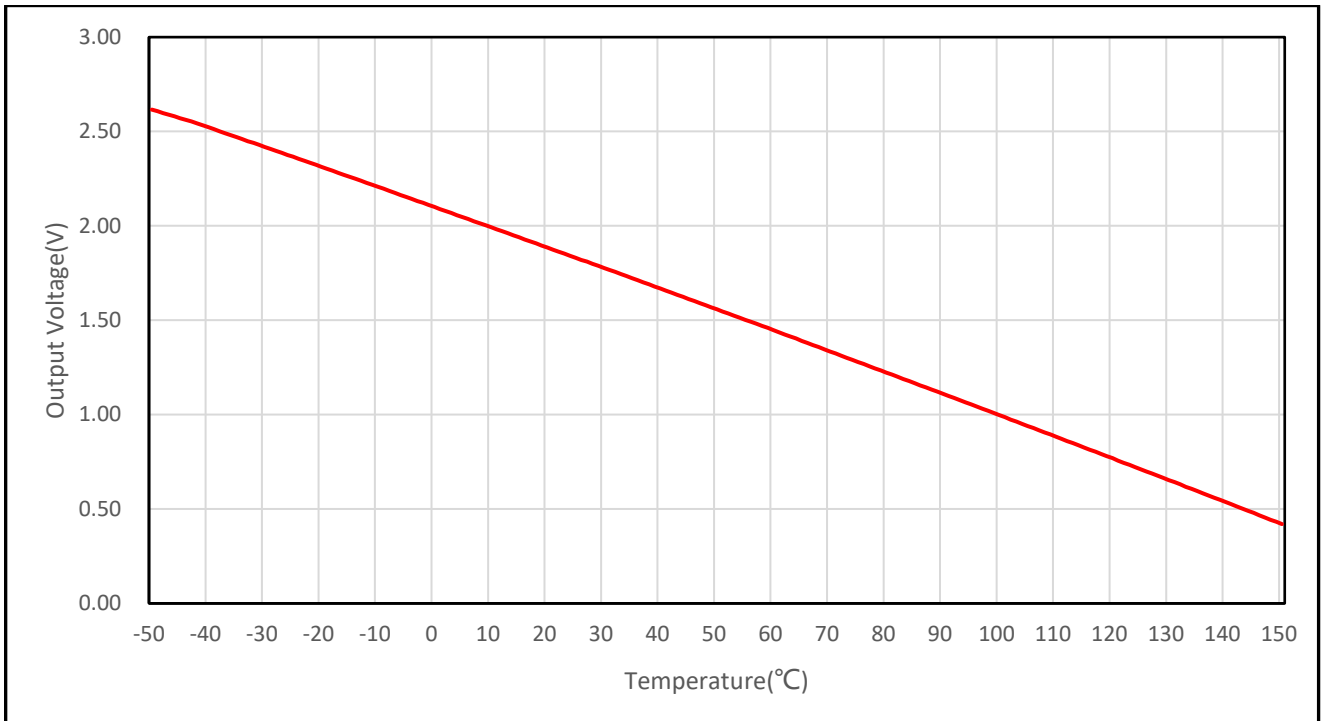

Figure 5.2 Output Voltage vs Temperature

6. Application Information

6.1. Capacitive Loads

As shown in the structure diagram, the output stage of NST86-Q1SCR is an amplifier. Generally, the output of the amplifier directly connected to the capacitive load is unstable. However, NST86-Q1SCR uses a special design, which makes it have 1000pF capacitive load capacity as shown in the [Figure 6.1](#). If a larger capacitor is connected to filter the noise, an isolation resistance should be added between the output of NST86-Q1SCR and the capacitor as shown in the [Table 6.1](#).

When the equipment is in an extremely noisy environment, it may be necessary to add an RC low-pass filter network to the output of NST86-Q1SCR, such as a 1μF capacitor and a 800Ω series resistor. This low-pass filter will improve the thermal response time of NST86-Q1SCR and has the function of filtering high-frequency noise as shown in the [Figure 6.2](#).

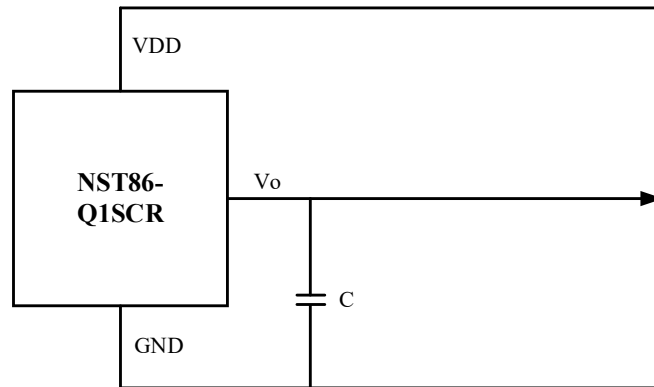

Figure 6.1 NST86-Q1SCR No Decoupling Required for Capacitive Loads Less than 1000pF

Table 6.1 Capacitive Loading Isolation

C (μF)	Minimum R (Ω)
1	800
0.1 to 1	1500
0.01 to 0.1	3000

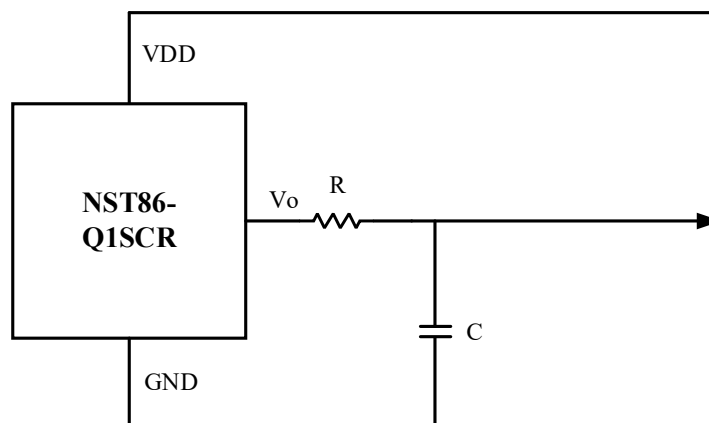

Figure 6.2 NST86-Q1SCR With RC Filter

6.2. Typical Application

As shown in [Figure 6.3](#), the NST86-Q1SCR has an extremely low supply current and a wide supply range, therefore, it can be easily driven by a battery. In order to reduce the noise in the output voltage, it is recommended to add a 0.1μF capacitor between the power and the ground.

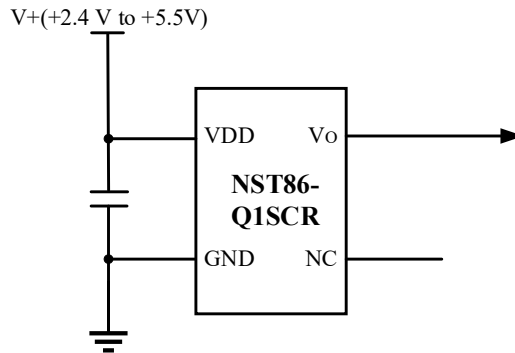

Figure 6.3 Typical Connections of the NST86-Q1SCR

6.3. System Examples

6.3.1. Conserving Power Dissipation with Shutdown

Although NST86-Q1SCR has extremely low power consumption, for power-sensitive applications it can simply be shutdown by driving its supply pin with the output of a logic gate as shown in [Figure 6.4](#).

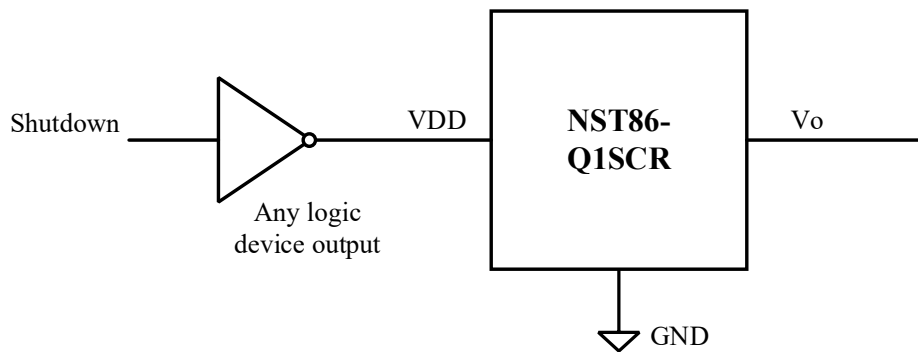

Figure 6.4 Conserving Power Dissipation with Shutdown

6.3.2. Analog-to-Digital Converter Input Stage

The input structure of most CMOS ADCs is sample and hold structure. When ADC charges the sampling capacitor, it needs to draw instantaneous current from the signal source (such as NST86-Q1SCR temperature sensor and many operational amplifiers). By adding RC filter to the output stage of NST86-Q1SCR, this requirement can be met. At this time, the instantaneous current is provided by the output capacitor. This ADC is shown as an example only, in [Figure 6.5](#).

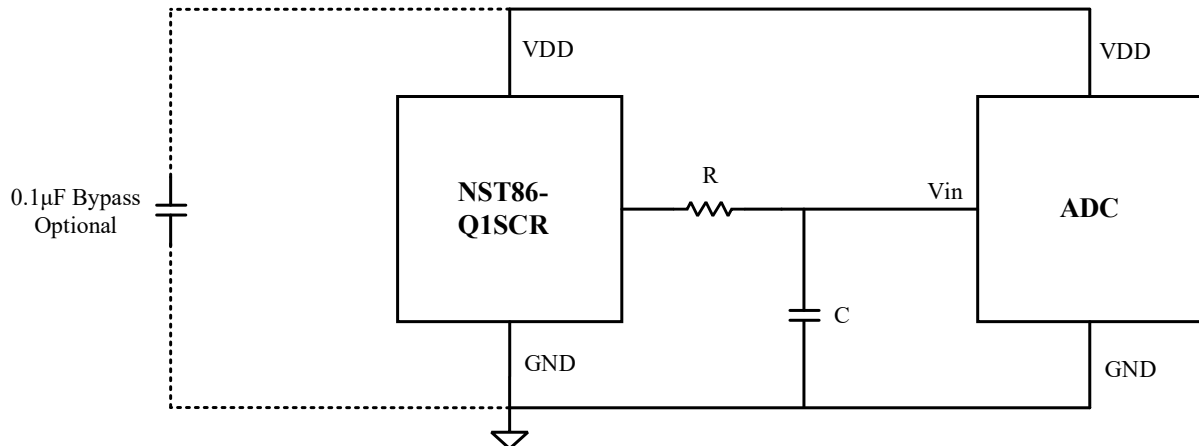
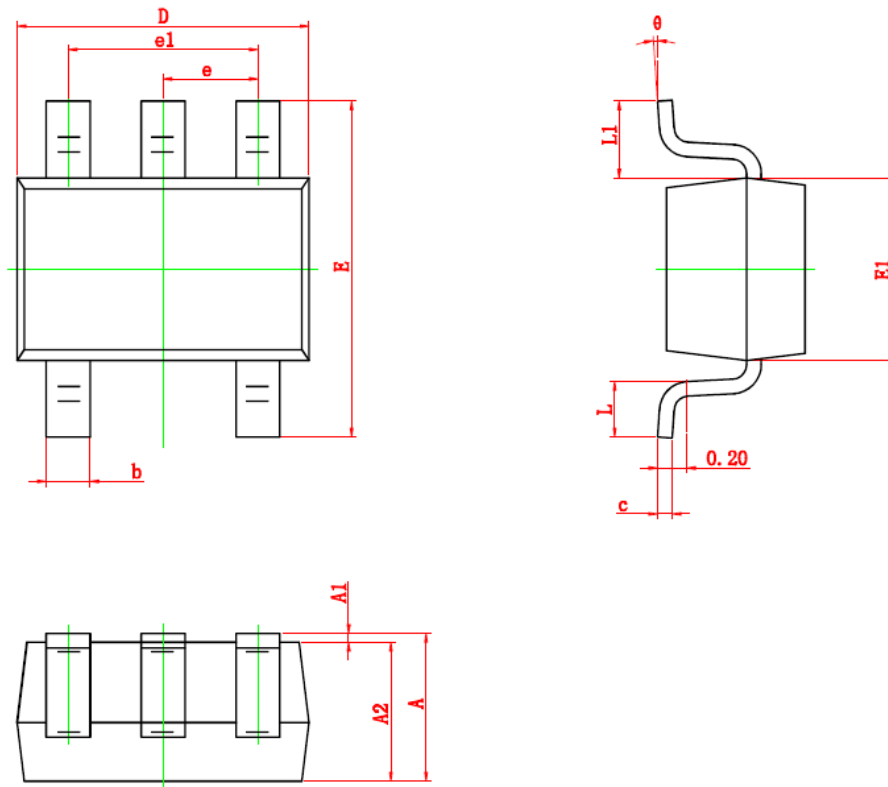

Figure 6.5 Suggested Connection to a Sampling Analog to Digital Converter Input Stage

7. Package Information

7.1. SC70 Package



Symbol	Dimensions In Millimeters		Dimensions In Inches	
	Min.	Max.	Min.	Max.
A	0.900	1.100	0.035	0.043
A1	0.000	0.100	0.000	0.004
A2	0.900	1.000	0.035	0.039
b	0.150	0.350	0.006	0.014
c	0.110	0.175	0.004	0.007
D	2.000	2.200	0.079	0.087
E	2.150	2.450	0.085	0.096
E1	1.150	1.350	0.045	0.053
e	0.650 TYP.		0.026 TYP.	
e1	1.200	1.400	0.047	0.055
L	0.260	0.460	0.010	0.018
L1	0.525 REF.		0.021 REF.	
θ	0°	8°	0°	8°

7.2. Tape and Reel Information

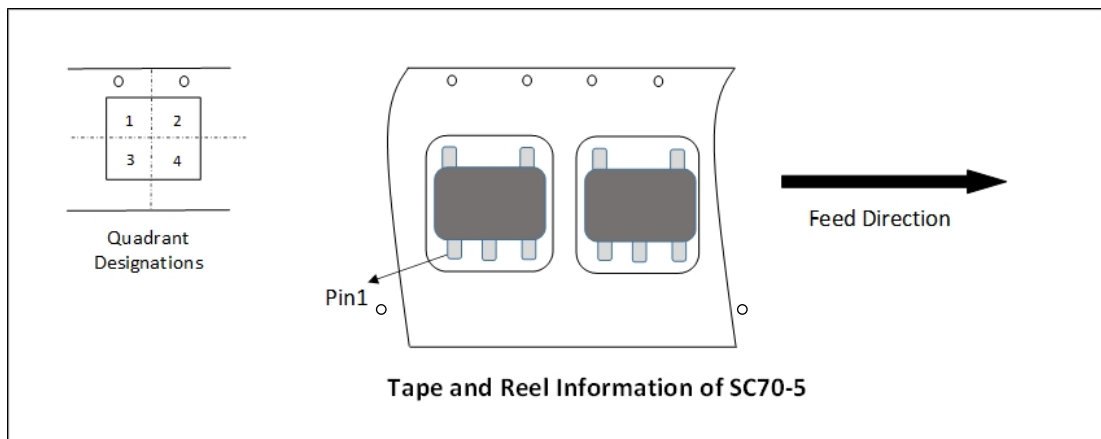
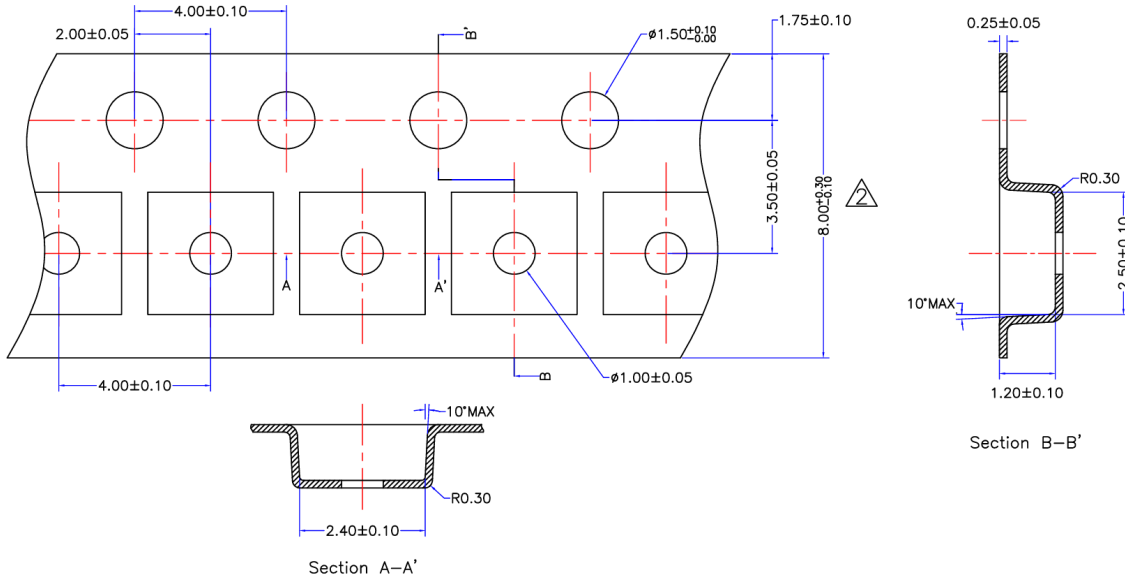
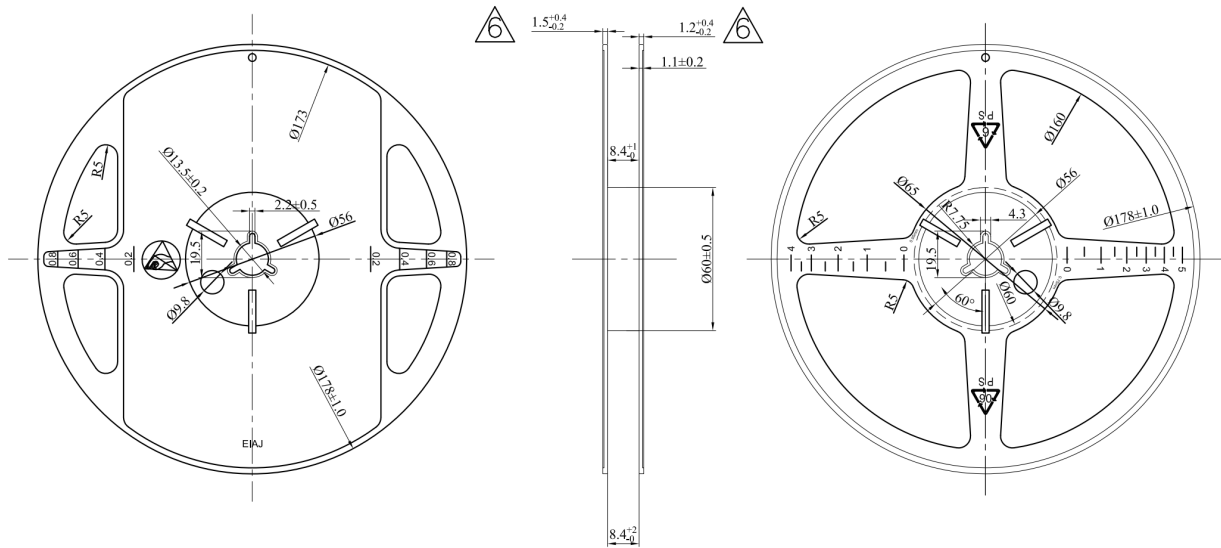

Tape and Reel Information of SOT-23(3)

7.3. Land Pattern

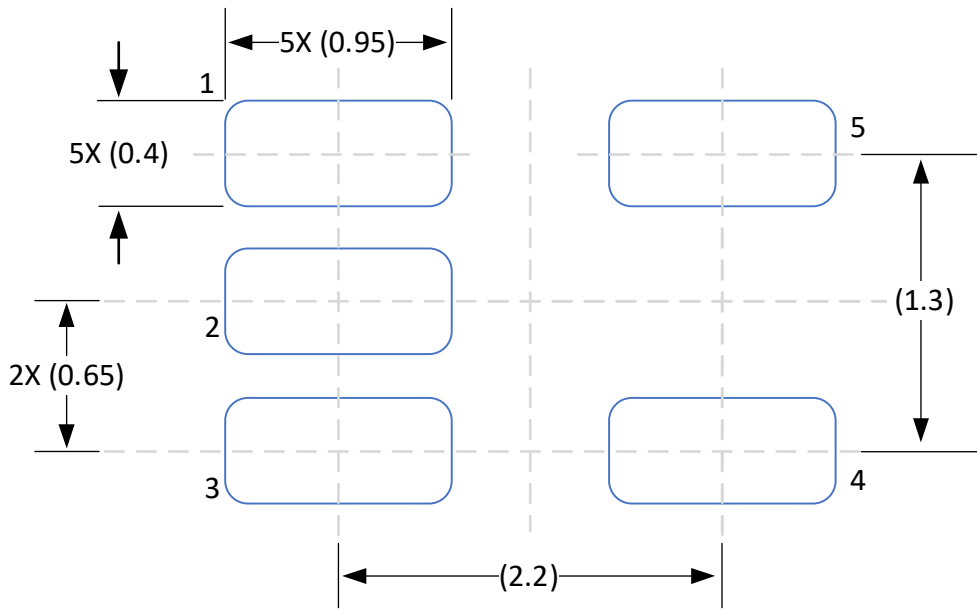

LAND PATTERN EXAMPLE

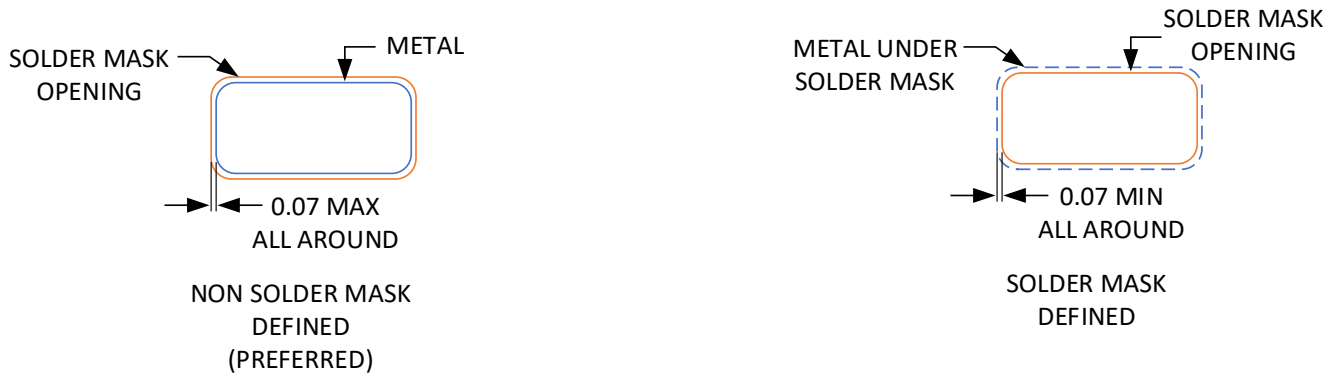

SOLDER MASK DETAILS

8. Order Information

<i>NST86-Q1SCR-Q1SCR</i>	<i>Unit</i>	<i>MSL</i>	<i>Marking</i>	<i>Description</i>
NST86-Q1SCR	3000ea/Reel	1	XXYY	SC-70 package, Reel
NOTE: All packages are RoHS-compliant with peak reflow temperatures of 260 °C according to the JEDEC industry standard classifications and peak solder temperatures (Reflow profile: J-STD-020E).				

9. Marking

	<i>Type</i>	<i>Line</i>	<i>Name</i>	<i>Remark</i>
NST86-Q1SCR	XXYY	Line 1	XX	Last 2 of the current year
			YY	Weekly

10. Revision History

<i>Revision</i>	<i>Description</i>	<i>Date</i>
1.0	Initial Version	2024/11/10

IMPORTANT NOTICE

The information given in this document (the “Document”) shall in no event be regarded as any warranty or authorization of, express or implied, including but not limited to accuracy, completeness, merchantability, fitness for a particular purpose or infringement of any third party’s intellectual property rights.

Users of this Document shall be solely responsible for the use of NOVOSENSE’s products and applications, and for the safety thereof. Users shall comply with all laws, regulations and requirements related to NOVOSENSE’s products and applications, although information or support related to any application may still be provided by NOVOSENSE.

This Document is provided on an “AS IS” basis, and is intended only for skilled developers designing with NOVOSENSE’s products. NOVOSENSE reserves the rights to make corrections, modifications, enhancements, improvements or other changes to the products and services provided without notice. NOVOSENSE authorizes users to use this Document exclusively for the development of relevant applications or systems designed to integrate NOVOSENSE’s products. No license to any intellectual property rights of NOVOSENSE is granted by implication or otherwise. Using this Document for any other purpose, or any unauthorized reproduction or display of this Document is strictly prohibited. In no event shall NOVOSENSE be liable for any claims, damages, costs, losses or liabilities arising out of or in connection with this Document or the use of this Document.

For further information on applications, products and technologies, please contact NOVOSENSE (www.novosns.com).

Suzhou NOVOSENSE Microelectronics Co., Ltd