

High Accuracy, Low-Power Temperature Sensor with SMBus and I²C Interface

Datasheet (EN) 2.2

Product Overview

The NST112 is a 1.5V to 3.6V micropower digital temperature sensor. The on-chip 14-bit analog-to-digital converter (ADC) provides resolution down to 0.015625°C. The device is specified at the full temperature range of -40°C to 125°C.

The NST112 communicates through a flexible 2-wire digital interface which is compatible with SMBus and I²C and supports 4 device addresses. The device offers a typical accuracy of 0.1°C, it is highly linear and does not require complex calculations or lookup tables to derive temperature.

NST112 has a four-ball wafer chip-scale package (DSBGA), making it suitable for on-board and off-line applications in the industrial and consumer markets.

Key Features

- High Accuracy Over -40°C to 125°C
25°C to 45°C: ±0.2°C (Max)
-40°C to 125°C: ±1°C (Max)
- High Resolution: 0.015625 °C
- Wide Supply Voltage: 1.5V to 3.6V
- Low Supply Sensitivity: 20m°C/V
- Shutdown current: 0.25 µA (Typ)
- Operating current: 5.7 µA(Typ) at 4Hz conversion cycle
- Supports Temperature Alert
- Supports up to 4 Device Addresses
- Digital Interface: SMBus, I²C
- 4-Ball WCSP (DSBGA) Package

Applications

- Electronic Thermometers
- Smart watches
- General System Thermal Management
- Computer Peripheral Thermal Protection
- Notebook Computers
- Industrial Internet of Things (IOT)
- Communications Infrastructure
- Power-system Monitors
- Thermal Protection
- Environmental Monitoring And HVAC

Device Information

Part Number	Package	Body Size
NST112A-CWLR	DSBGA (4)	0.75mm × 0.75mm
NST112B-CWLR	DSBGA (4)	0.75mm × 0.75mm
NST112C-CWLR	DSBGA (4)	0.75mm × 0.75mm
NST112D-CWLR	DSBGA (4)	0.75mm × 0.75mm

Typical Application

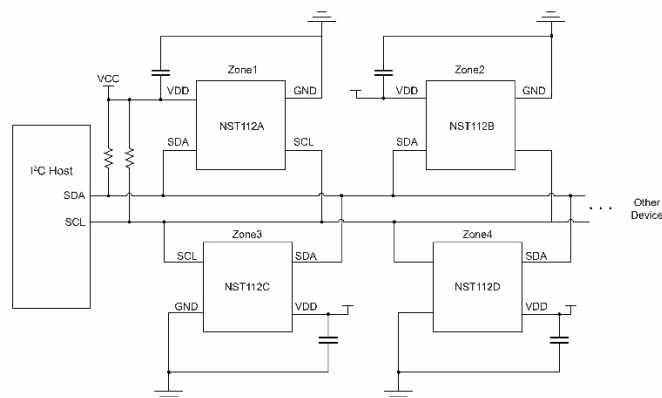

INDEX

1. PIN CONFIGURATION AND FUNCTIONS 4

2. ABSOLUTE MAXIMUM RATINGS 4

3. RECOMMENDED OPERATING CONDITIONS 4

4. SPECIFICATIONS 5

 4.1. ELECTRICAL CHARACTERISTICS 5

 4.2. I²C TIMING DIAGRAM 6

 4.3. I²C TIMING CHARACTERISTICS 6

 4.4. TYPICAL CHARACTERISTICS 9

5. FUNCTION DESCRIPTION 11

 5.1. OVERVIEW 11

 5.2. FUNCTIONALITY 11

 5.2.1. CONTINUOUS-CONVERSION MODE 11

 5.2.2. SHUTDOWN MODE 12

 5.2.3. ONE-SHOT 12

 5.2.4. RESOLUTION 12

 5.2.5. HIGH-RESOLUTION MODE 13

 5.2.6. EXTENDED MODE 14

 5.2.7. TEMPERATURE ALERT 15

 5.3. I²C INTERFACE 16

 5.3.1. I²C BUS ADDRESS 16

 5.3.2. WRITING AND READING OPERATION 16

 5.3.3. GENERAL CALL 17

 5.3.4. HIGH-SPEED MODE 17

 5.3.5. I²C TIMEOUT 17

 5.4. ON-CHIP REGISTERS 18

 5.4.1. POINTER REGISTER 18

 5.4.2. TEMPERATURE REGISTER 19

 5.4.3. CONFIGURATION REGISTER 19

 5.4.4. HIGH AND LOW LIMIT REGISTERS 20

 5.4.5. PART ID REGISTER 21

6. TYPICAL APPLICATION 22

 6.1. NOISE REDUCTION 22

 6.2. TYPICAL APPLICATION CIRCUIT 22

7. PACKAGE INFORMATION 23

8. EXAMPLE BOARD LAYOUT	24
9. ORDER INFORMATION	25
10. MARKING.....	26
11. TAPE AND REEL INFORMATION	27
12. REVISION HISTORY	28

1. PIN Configuration and Functions

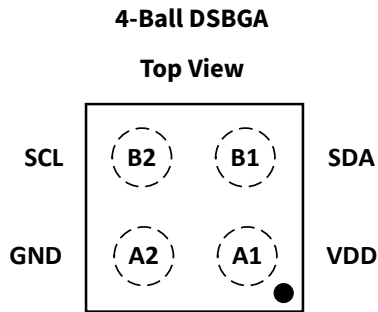

Pin No.	Symbol	Type	Function
A1	VDD	Power	Supply voltage, 1.5 V to 3.6 V
A2	GND	GND	Ground
B1	SDA	I/O	Serial data. Open-drain output. requires a pullup resistor.
B2	SCL	I	Serial clock. requires a pullup resistor.

2. Absolute Maximum Ratings

Parameters	Symbol	Min	Typ	Max	Unit
Supply Voltage Pin (VDD)	VDD	-0.3		4	V
Voltage at SCL and SDA Pins	SCL, SDA	-0.3		4	V
Storage Temperature		-60		155	°C
Operation Temperature	T _{Boperation}	-55		125	°C
Maximum Junction Temperature				155	°C
ESD Susceptibility	HBM	±5			KV
	CDM	±2			KV

3. Recommended Operating Conditions

Parameters	Symbol	Min	Typ	Max	Unit	Comments
Power Supply Voltage	VDD	1.5		3.6	V	
Operation Temperature Range		-40		125	°C	

4. Specifications

4.1. Electrical Characteristics

At $T_A = +25^\circ\text{C}$ and $V_{DD} = 1.8\text{V}$, $R_{PU} = 5.1\text{k}\Omega$, unless otherwise noted.

Parameters	Symbol	Min	Typ	Max	Unit	Comments
Supply						
Supply Voltage Range	VDD	1.5		3.6	V	
Supply Sensitivity			20		m°C/V	from 25 °C to 45 °C
Average Quiescent Current	$I_Q^{(1)}$		5.7		μA	I ² C bus inactive
			8.7		μA	I ² C bus active, SCL frequency = 400 kHz
			25		μA	I ² C bus active, SCL frequency = 2.8 MHz
Shutdown Current	I_{SD}		0.25		μA	I ² C bus inactive
			3.1		μA	I ² C bus active, SCL frequency = 400 kHz
			22		μA	I ² C bus active, SCL frequency = 2.8 MHz
Temperature Accuracy and Resolution						
Temperature Range		-40		125	°C	
Resolution			0.015625		°C	14bit
Accuracy @ DSBGA (4)		-0.2	±0.1	0.2	°C	from 25 °C to 45 °C
		-0.5	±0.2	0.5	°C	from -40 °C to 125 °C
		-1	±0.5	1	°C	from -40 °C to 125 °C, VDD = 1.5 to 3.6V
Conversion Time	T_{CONV}		20	30	ms	
Digital DC Characteristics						
High-level Input Voltage	V_H	$V_{DD} \cdot 0.7$		$V_{DD} + 0.3$	V	
Low-level Input Voltage	V_L	-0.3		$V_{DD} \cdot 0.3$	V	
High-level Input Current				1	μA	
Low-level Input Current				-1	μA	
Digital Inputs Capacitance	C_{IN}		5		pF	
Output Leakage Current	I_{OH}			1	μA	High-level, $V_{OH} = 5\text{V}$
Low-level Output Voltage	V_{OL}			0.4	V	$I_{OL} = 3\text{ mA}$
I ² C Bus Time OUT Time	$T_{TIMEOUT}$		30		ms	
Thermal Response						
Response Time			0.1		s	Stirred oil thermal setting to 63% of final value
Drift						
Drift ⁽²⁾			0.06		°C	

(1) At 4-Hz conversion cycle.

(2) Drift performance after 500hours at 125 °C

4.2. I²C Timing Diagram

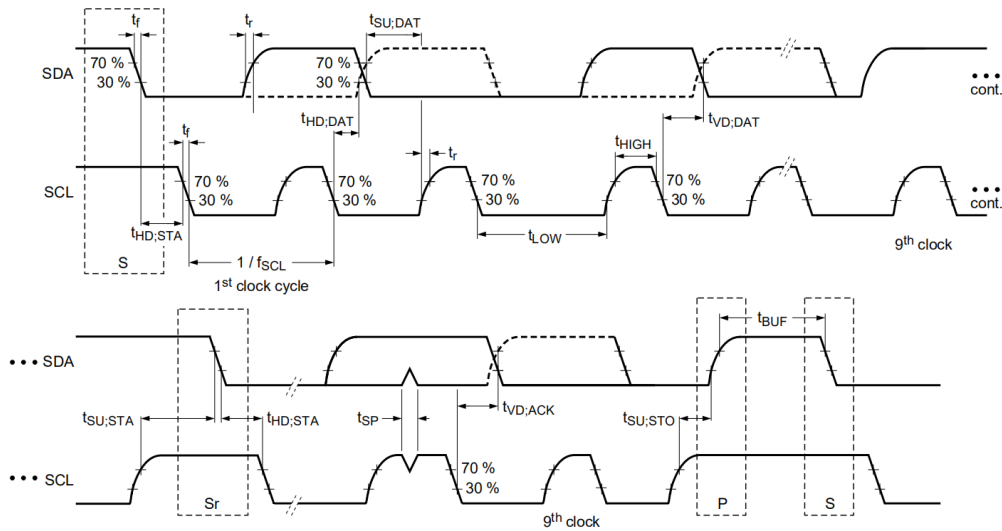

Figure 4.1 I²C Timing Diagram

4.3. I²C Timing Characteristics

Parameters	Symbol	Fast Mode		High-Speed Mode		Unit	Comments
		Min	Max	Min	Max		
SCL Operating Frequency	f_{SCL}	0.001	0.4	0.001	2.8	MHz	
Bus-free Time	t_{BUF}	1300		160		ns	between STOP and START
Hold time after Repeated START Condition	$t_{HD,STA}$	600		160		ns	after this period, the first clock is generated
Repeated START Setup Time	t_{SUSTA}	600		160		ns	
STOP condition Setup Time	t_{SUSTO}	600		160		ns	
Data Hold Time	T_{HDDAT}	100	900	25	105	ns	
Data Setup Time	T_{SUDAT}	100		25		ns	
SCL Clock Low Period	T_{LOW}	1300		210		ns	
SCL Clock High Period	T_{HIGH}	600		60		ns	
Data Fall Time	t_{FD}		300		80	ns	
Data Rise Time	t_{RD}		300			ns	
			1000			ns	SCLK ≤ 100 kHz
Clock Fall Time	t_{FC}		300		40	ns	
Clock Rise Time	t_{RC}		300		40	ns	

The NST112 of temperature sensor are SMBus, and I²C interface-compatible. The device support various operations as [Table 4.3](#). The following list provides bus definitions. Parameters for [Figure 4.1](#) are defined in the [Timing Requirements](#). Bus definitions are:

Bus Idle: Both SDA and SCL lines remain high.

Start Data Transfer: A high-to-low transition of SDA with SCL high is a START condition which must precede any other command (see [Figure 4.1](#)).

Stop Data Transfer: A low-to-high transition of SDA with SCL high is a STOP condition. The termination of each data transfer can be done with a RESTART or STOP.

Data Transfer: The amount of data bytes transferred between START and STOP is controlled by the master and is unlimited. The receiver acknowledges the transfer of data.

Acknowledge: All addresses and data words are serially transmitted to and from the device in 8-bit words. The device sends a zero to acknowledge that it has received each word when the address is matched. This happens during the ninth clock cycle. The data transfer can be terminated by the host generating a not-acknowledge during the host receiving data.

Table 4.3 NST112 I²C Operations

NO	I ² C Operations	Figures
1	Two-Wire Timing Diagram for Write Word Format	Figure 4.2
2	Two-Wire Timing Diagram for Read Word Format	Figure 4.3

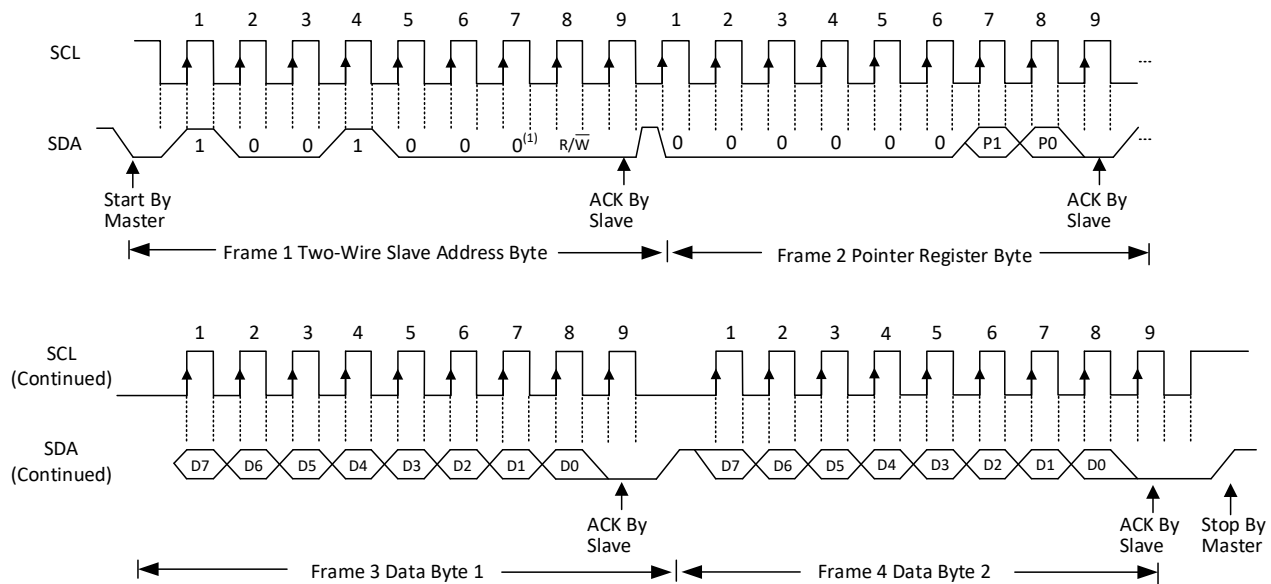

(1) Slave address 1001000 is shown.

Figure 4.2. Two-Wire Timing Diagram for Write Word Format

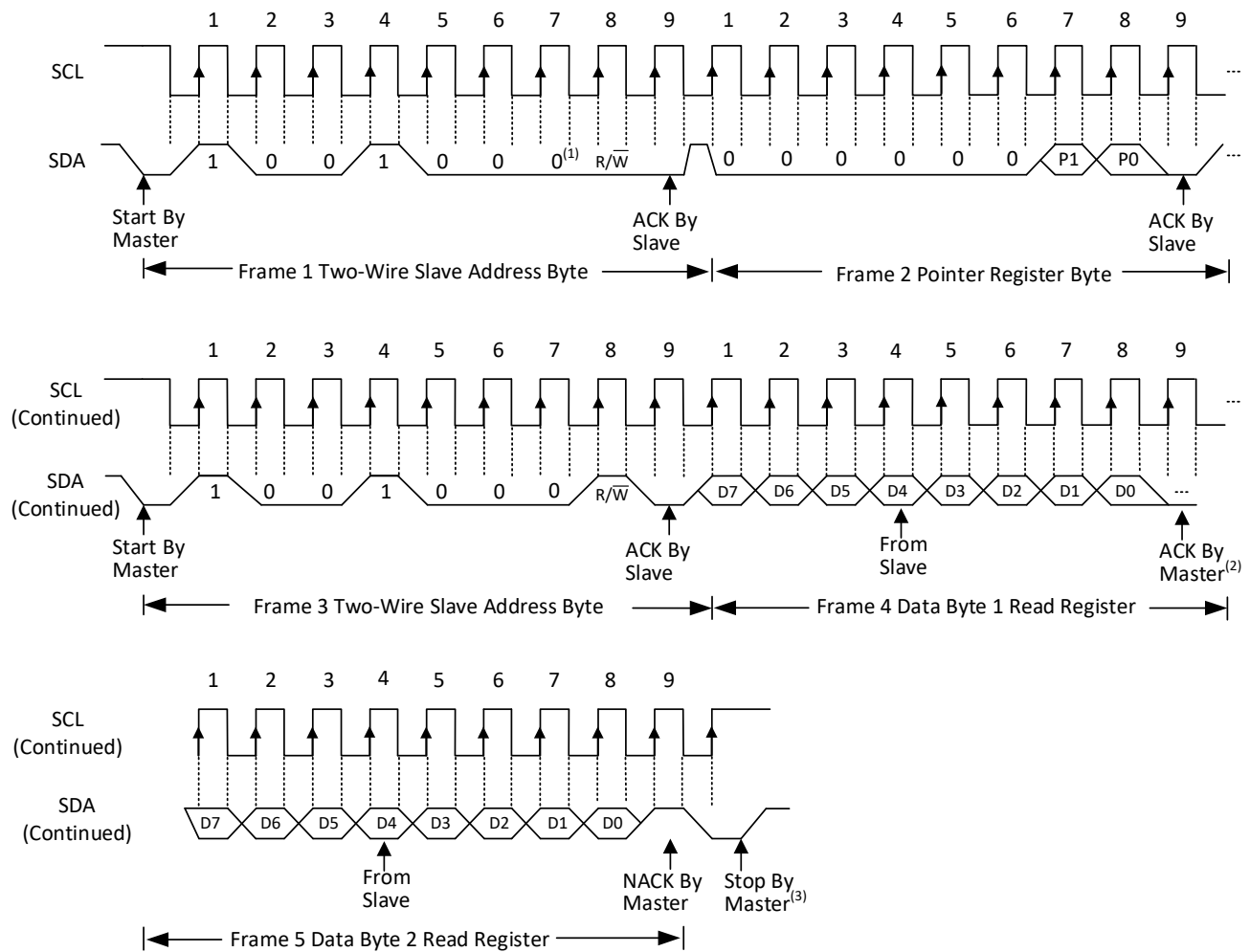

- (1) Slave address 1001000 is shown.
- (2) Master should leave SDA high to terminate a single-byte read operation.
- (3) Master should leave SDA high to terminate a two-byte read operation.

Figure 4.3. Two-Wire Timing Diagram for Read Word Format

4.4. Typical Characteristics

At $T_A = +25^\circ\text{C}$ and $V_{DD} = 1.8\text{V}$, high resolution mode, continuous-conversion mode, conversion rate 4SPS, unless otherwise noted.

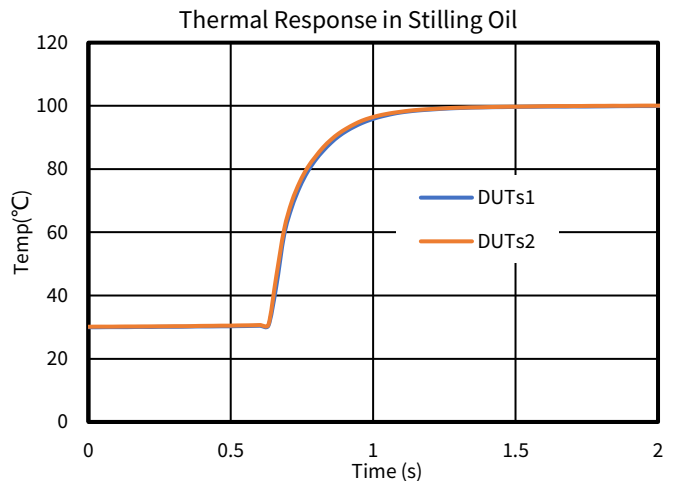
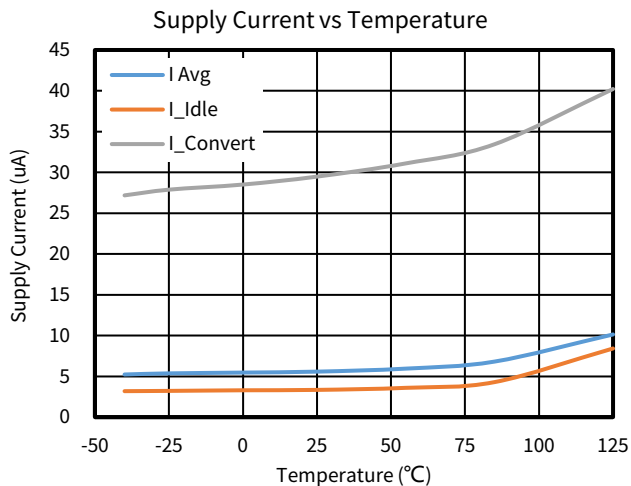
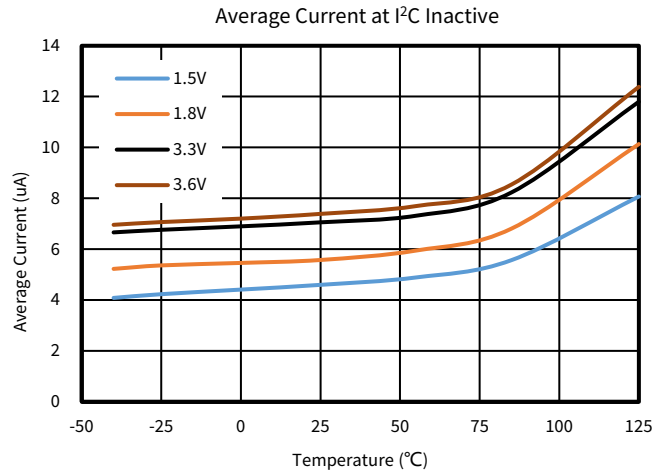
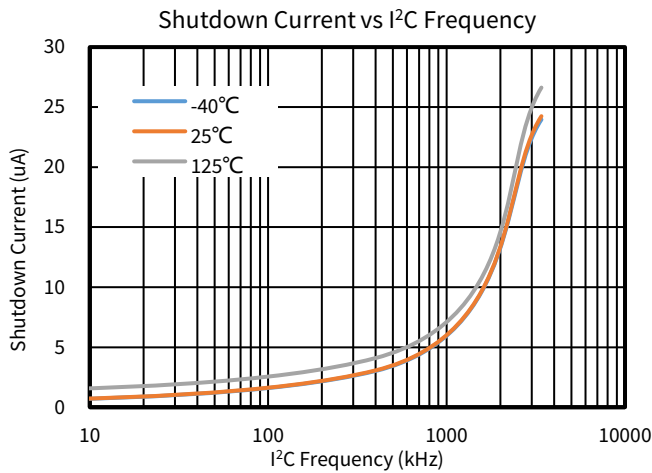
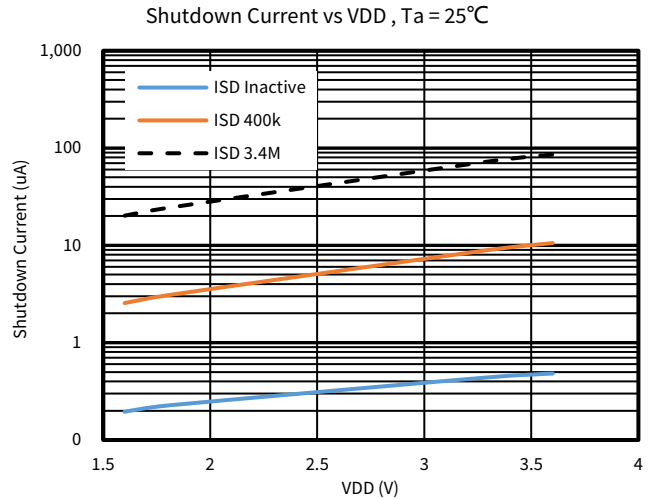
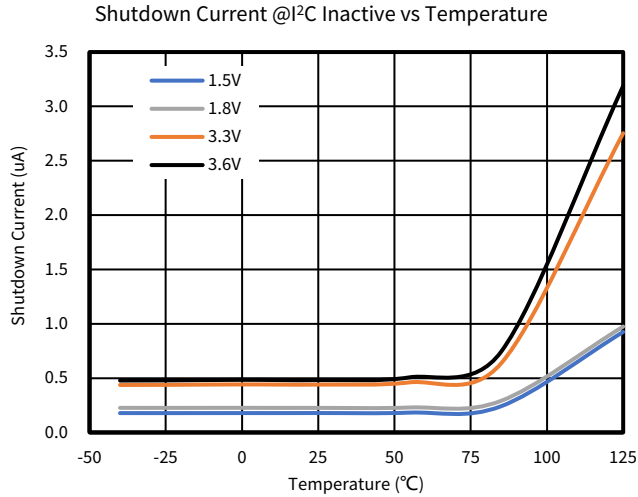

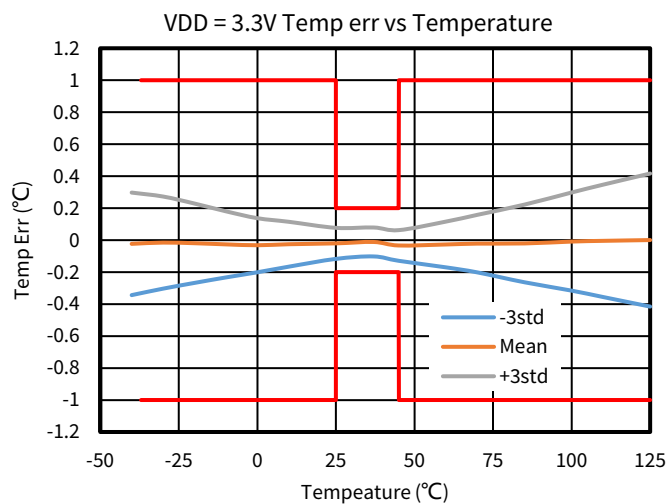
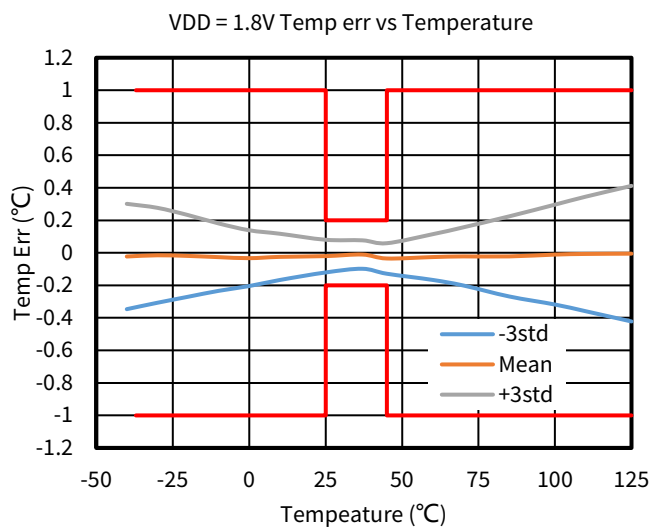
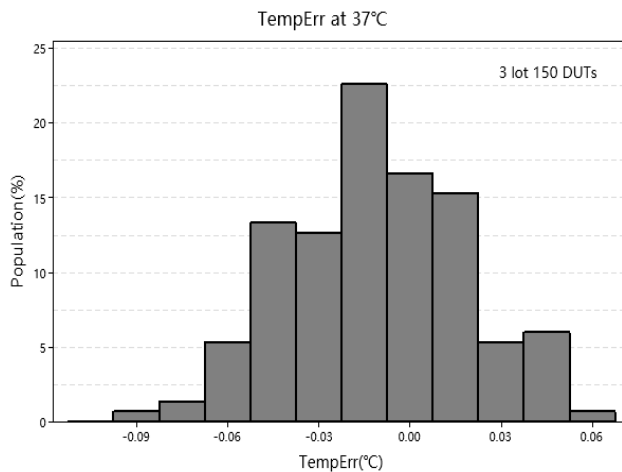
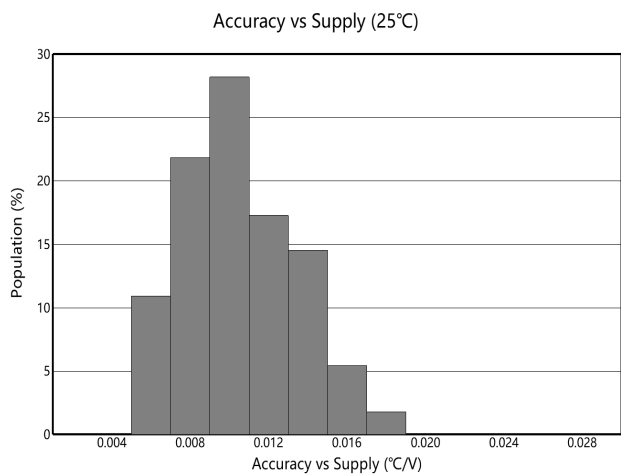

5. Function Description

5.1. Overview

The NST112 is a 1.5V to 3.6V micropower digital temperature sensor and include a PNP-BJT type temperature sensor and 14-bit ADC (Σ - Δ ADC). The device is specified at the full temperature range of -40 °C to 125 °C with a 0.015625°C resolution. The NST112 communicates through a flexible 2-wire digital interface which is compatible with SMBus and I²C and supports 4 device addresses. The I²C Bus has an integrated low-pass that increase communication reliability in noisy environments. NST112 also incorporates a digital comparator that compares a series of readings (the number of which can be selected by the user) with user-programmable setpoint values.

NST112 has a four-ball wafer chip-scale package (DSBGA), making it suitable for on-board and off-line applications in the industrial and consumer markets.

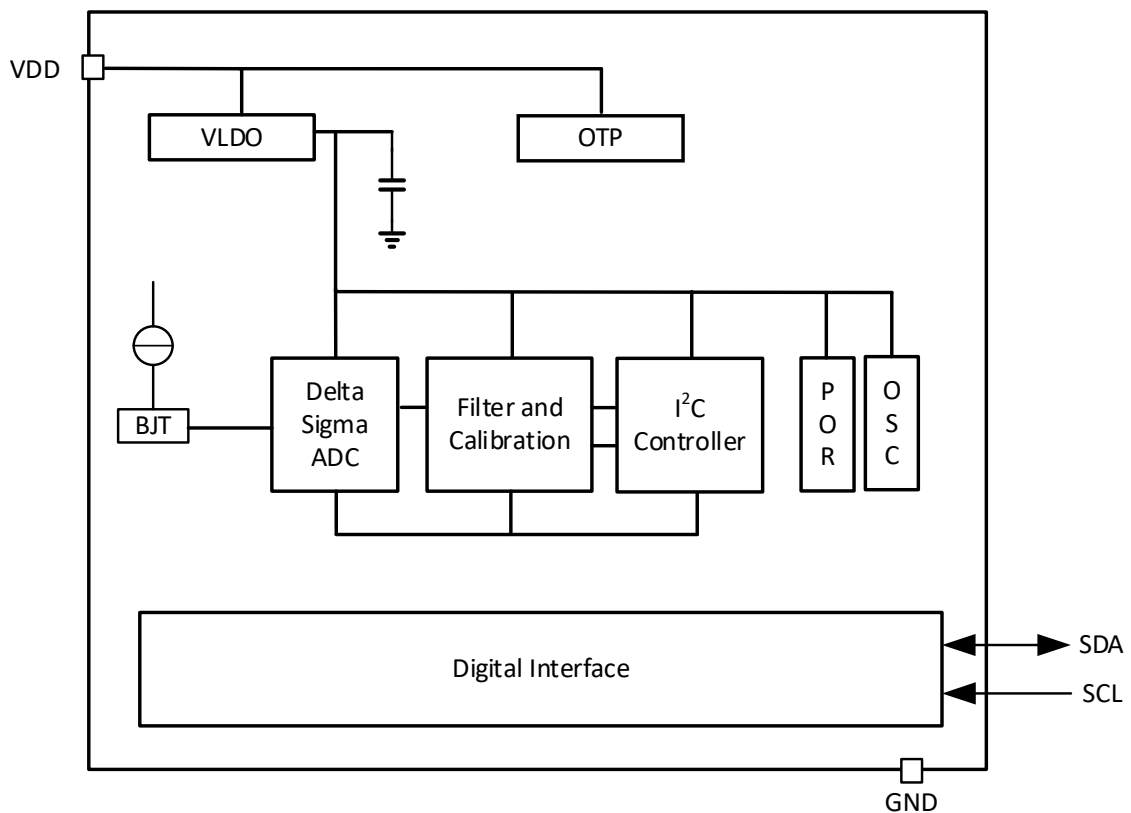

Figure 5.1 NST112 Functional Block Diagram

5.2. Functionality

5.2.1. Continuous-Conversion Mode

The default mode of the NST112 after power-up is continuous conversion mode. In continuous conversion mode, the ADC performs temperature conversions continuously and saves the result of each conversion to the temperature register, overwriting the result of the previous conversion. The NST112 device provides four conversion rates, which are controlled by CR. The NST112 device provides four conversion rates, which are controlled by CR1 and CR0 in the configuration register, the default conversion rate is 4Hz. [Table 5.1](#) shows the conversion rates corresponding to the configuration of CR1 and CR0.

Table 5.1. Conversion Rate Settings

CR1	CR0	CONVERSION RATE
0	0	0.25 Hz
0	1	1 Hz
1	0	4 Hz (default)
1	1	8 Hz

As soon as the NST112 is powered up or a general call reset is completed, a temperature transition is immediately performed, as shown in [Figure 5.1](#). The time for each temperature transition is 20ms (typical). The current during temperature conversion is 29uA (+25 °C typically). The current of delay during two conversions is 3.5uA (+25 °C typically).

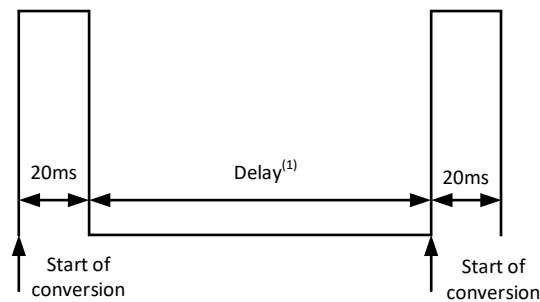

(1) Delay is set by CR1 and CR0.

Figure 5.1. Conversion Start

5.2.2. Shutdown Mode

For power-sensitive applications, The NST112 device offers a low-power shutdown mode, which reducing current consumption to typically less than 0.25 μ A. Shutdown mode is enabled when write 1 to SD bit of the configuration register. In shutdown mode a One-shot command can be sent to perform a temperature transition, and the device shuts down automatically when the temperature transition is complete. When SD write to 0, the device maintains a continuous conversion state.

For the NST112, the [time-out](#) feature is turned off in Shutdown Mode.

5.2.3. One-shot

The NST112 supports a one-shot temperature measurement mode when continuous temperature monitoring is not required. First set the chip into shutdown mode, write 1 to the OS bit to wake up the chip once and perform a temperature conversion. When temperature conversion is in progress, OS bit is 0. After the single conversion is complete, the device returns to the Shutdown state. At the end of the conversion, the OS bit reads 1.

Using one shot mode can achieve faster conversion frequency, temperature conversion takes 20ms typically, however, reading the temperature value needs less than 20us, Therefore, using the one-shot mode can achieve 30 times faster than the fastest temperature conversion rate in the continuous mode.

5.2.4. Resolution

After the nst112 powered on, the default output code format is 12bit with a resolution of 0.0625 °C. The temperature digital output is stored in the read-only temperature register after each temperature measurement conversion. Two bytes must be read to obtain data, and byte 1 is the most significant byte (MSB), followed by byte 2. The first 12 bits use to indicate temperature. The data format for temperature is listed in [Table 5.2](#). Negative numbers are represented in binary twos complement format. Following power-up or reset, the Temperature register reads 0°C until the first conversion is complete.

Table 5.2. Temperature Data 12 Bit Format at Normal Mode

Temperature (°C)	Binary	HEX
150	0111 1111 1111 (0000)	7FF0
128	0111 1111 1111 (0000)	7FF0
127.9375	0111 1111 1111 (0000)	7FF0
100	0110 0100 0000 (0000)	6400
85	0101 0101 0000 (0000)	5500
50	0011 0010 0000 (0000)	3200
20	0001 0100 0000 (0000)	1400
0.0625	0000 0000 0001 (0000)	0010
0	0000 0000 0000 (0000)	0000
-0.0625	1111 1111 1111 (0000)	FFF0
-20	1110 1100 0000 (0000)	EC00
-50	1100 1110 0000 (0000)	CE00

5.2.5. High-Resolution Mode

The NST112 integrates a 14-bit delta sigma ADC, so it has the ability to output 14-bit data. When HRES bit writes 1, NST112 is configured into 14-bit high-resolution mode, meanwhile R1 and R0 bits in the configuration register are invalid. Compared with the default 12-bit mode, the low byte of the temperature data register has two more significant bits. 1 LSB is equal to 0.015625°C. The data format for temperature is listed in [Table 5.3](#). Negative numbers are represented in binary two's complement format.

NST112 has very low noise, [Figure 5.2](#) shows the output code distribution of continuous reading for 4 hours using high-resolution mode at 25°C. During the continuous reading for 4 hours, the difference between the maximum value and the minimum value is only 5LSB.

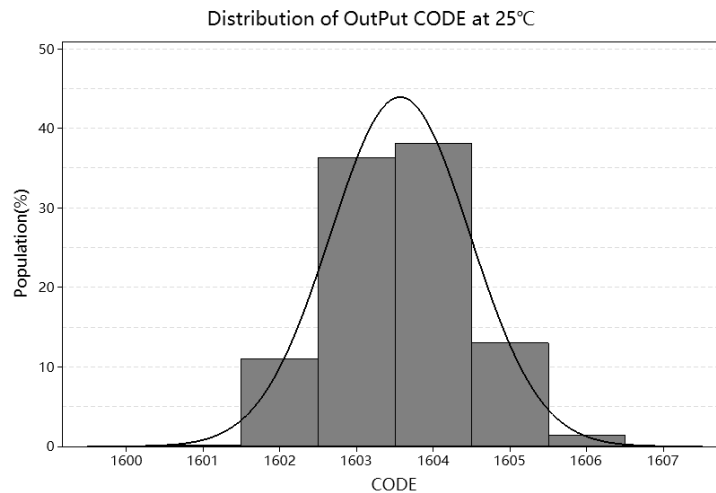

Figure 5.2. Distribution of Output CODE at 25°C

Table 5.3. Temperature Data 14 Bit Format at Normal Mode

<i>Temperature (°C)</i>	<i>Binary</i>	<i>HEX</i>
150	0111 1111 1111 11(00)	7FFC
128	0111 1111 1111 11(00)	7FFC
127.984375	0111 1111 1111 11(00)	7FFC
100	0110 0100 0000 00(00)	6400
85	0101 0101 0000 00(00)	5500
50	0011 0010 0000 00(00)	3200
20	0001 0100 0000 00(00)	1400
0.015625	0000 0000 0000 01 (00)	0004
0	0000 0000 0000 00(00)	0000
-0.015625	1111 1111 1111 11(00)	FFFC
-20	1110 1100 0000 00(00)	EC00
-50	1100 1110 0000 00(00)	CE00

5.2.6. Extended Mode

The NST112 has two data format modes, normal mode (EM=0) and extended mode (EM=1), which can be configured through the configuration registers. In normal mode, temperature data and HIGH and LOW limit data are in 12bit or 14bit data format. The extended mode can support temperature data higher than 128°C and is configured to 13bit or 15bit data format through configuration registers. The data format for temperature is listed in [Table 5.4](#). The extended mode only extends the temperature measurement range, and the resolution is not improved compared with the normal mode.

Table 5.4. Temperature Data Format Extended Mode

<i>Temperature (°C)</i>	<i>Digital Output</i>			
	<i>13bit format</i>		<i>15bit format</i>	
	<i>Binary</i>	<i>HEX</i>	<i>Binary</i>	<i>HEX</i>
150	0100 1011 0000 0 (000)	4B00	0100 1011 0000 000(0)	4B00
128	0100 0000 0000 0 (000)	4000	0100 0000 0000 000(0)	4000
127.9375	0011 1111 1111 1 (000)	3FF8	0011 1111 1111 100(0)	3FF8
100	0011 0010 0000 0 (000)	3200	0011 0010 0000 000(0)	3200
85	0010 1000 0000 0 (000)	2A80	0010 1000 0000 000(0)	2A80
50	0001 1001 0000 0 (000)	1900	0001 1001 0000 000(0)	1900
20	0000 1100 1000 0 (000)	0A00	0000 1100 1000 000(0)	0A00
0.125	0000 0000 0001 0 (000)	0010	0000 0000 0001 000(0)	0010
0	0000 0000 0000 0 (000)	0000	0000 0000 0000 000(0)	0000
-0.125	1111 1111 1111 0 (000)	FFF0	1111 1111 1111 000(0)	FFF0
-20	1111 0110 0000 0 (000)	F600	1111 0110 0000 000(0)	F600
-50	1110 0111 0000 0 (000)	E700	1110 0111 0000 000(0)	E700

5.2.7. Temperature Alert

The NST112 provides temperature alert functions which work as comparator mode. A fault condition is generated when the temperature measurement value exceeds the THIGH and TLOW register values, and the number of fault conditions activated by the trigger alert can be programmed by the fault queue. False triggering of alerts due to temperature noise can be avoided by using a fault queue. When the fault number exceeds the fault queue, the AL bit in the configuration register will flip. The effective polarity of the AL bit can be configured by the POL bit in the configuration register. the AL bit is activated until the measured temperature falls below the value of TLOW by the same number.

5.2.7.1. Alert

As shown in [Figure 5.3](#), the AL bit is a read-only bit that allows user to get the state of ALERT in comparator mode by reading the AL. When POL is 0, AL is "1" until the measured temperature is equal to or exceeds the T_{HIGH} temperature of fault queues set, and AL is "0" until the measured temperature is falls below the T_{LOW} temperature of fault queues set, and it again reads as "1".

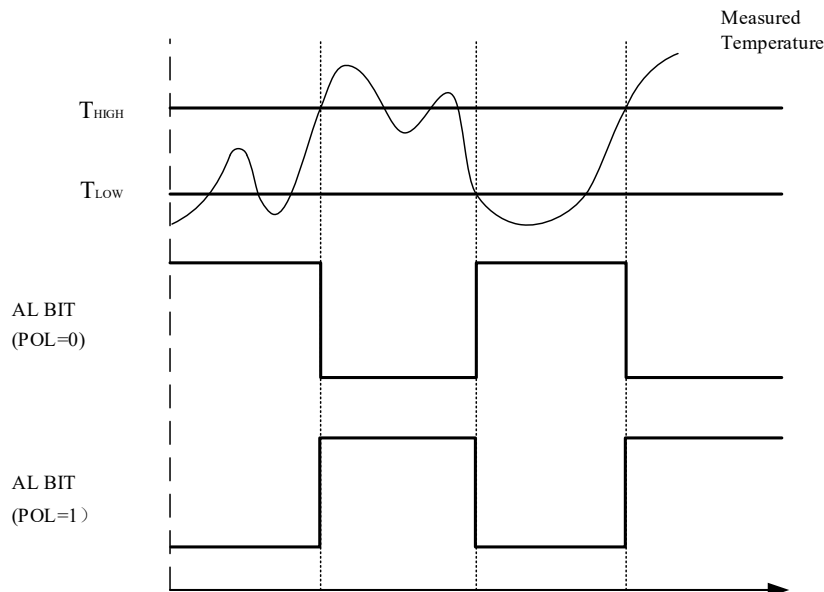

Figure 5.3. Output Transfer Function Diagrams

5.2.7.2. Polarity

The polarity bit allows the user to control the output polarity of the NST112 AL bit. When POL bit is 0, AL bit is active low, when POL bit is 1, AL bit is active high, while the state of AL bit is inverted. And the operation of AL bit in different modes is shown in [Figure 5.3](#).

5.2.7.3. Fault Queue

A fault condition is generated when the temperature measurement value exceeds the T_{HIGH} and T_{LOW} register values, and the number of fault conditions activated by the trigger alert can be programmed by the fault queue. False triggering of alerts due to temperature noise can be avoided by using a fault queue. [Table 5.5](#) defines the number of measured faults that can be programmed to trigger a device alert condition.

Table 5. 5. Fault Settings of the NST112

F1	F0	CONSECUTIVE FAULTS
0	0	1
0	1	2
1	0	4
1	1	6

5.3. I²C Interface

NST112 is compatible with SMBus and I²C interfaces, and transmits information to the master. NST112 has four slave addresses, which can support the simultaneous use of four NST112 devices on the bus, data on the I²C-bus can be transferred at rates of up to 100 kbit/s in the Standard-mode, up to 400 kbit/s in the Fast-mode, or up to 2.8 Mbit/s in the High-speed mode. All data bytes are transferred MSB-firstly.

5.3.1. I²C Bus Address

For communication between the master and the slave, a byte address needs to be sent first, including 7bit slave address bits and 1bit read and write direction bits. The NST112 is available in four versions, each with a different slave address, as shown in [Table 5.5](#) These addresses can be used as either a location or a temperature zone designator.

Table 5. 6. Device Slave Addresses for DSBGA

PRODUCT	TWO-WIRE ADDRESS	TEMPERATURE ZONE
NST112A	1001000	Zone1
NST112B	1001001	Zone2
NST112C	1001010	Zone3
NST112D	1001011	Zone4

5.3.2. Writing and Reading Operation

Writing operation is triggered by sending the slave address in write mode (R/W=0), then the master sends pointer register, and send the data byte afterwards. The transaction is ended by a STOP condition. The details of this sequence are shown in [Figure 4.1](#).

During writing operation, NST112 is used as the slave receiver. The master transfers the slave address byte firstly, including 7 address bits and 1bit write direction bits, NST112 acknowledges after receiving the valid address. the second byte transmitted by master is the pointer register address, then NST112 acknowledges and the next byte of data is written to the pointer register. The master can terminate communication by generating a STOP condition. The details of this sequence are shown in [Figure 4.2](#).

To be able to read registers, firstly the register address must be sent in write mode (R/W=0), then either a stop or a repeated start condition must be generated. When the slave is addressed as read mode (R/W=1), then the slave sends out 1 byte data. After reading the data the master needs to generate the NACK and stop condition to end the transaction. The details of this sequence are shown in [Figure 4.3](#).

If repeated reads from the same register are required, it is not necessary to send the pointer register byte repeatedly because the NST112 remembers the pointer register value until it is changed by the next write operation.

5.3.3. General Call

The NST112 provides the general call function. when the general call address (0 000 000) sent by host is received and the R/W bit is 0, the device replies to the command. If the second byte is 00000110, the NST112 latches the state of its address pins and resets its internal registers to the value at power-up.

5.3.4. High-Speed Mode

The NST112 supports bus operation above 400 kHz, requiring that the master device must switch the bus to high-speed mode operation by issuing a high-speed mode master code (00001XXX) in the first byte after the START condition. The NST112 does not acknowledge this byte, the NST112 switches the input filter of SCL, SDA and output filter of SDA to high-speed mode, allowing data transfer up to 2.8 MHz. After issuing the master code for high-speed mode, the master will transmit a two-wire slave address to initiate the data transfer operation. The bus will continue to operate in high-speed mode until a stop signal appears on the bus. Once the stop signal is received, the SCL, SDA input filter and SDA output filter of the NST112 switch to the fast mode.

5.3.5. I²C Timeout

The NST112 resets the I²C interface when the SCL or SDA is continuously pulled low for 30ms (typical) between the START and STOP signals, the NST112 release the SDA and SCL line and waits for the master to initiate a START condition. To avoid activating the timeout function, the SCL operating frequency must be maintained at a rate of at least 1kHz.

5.4. On-Chip Registers

As [Figure 5.4](#) shows the on-chip register structure of the NST112. The Pointer Register of the device is used to address a given data register. As [Table 5.6](#), The Pointer Register uses the three bits to identify which of the data registers should respond to a read or write command. After power on reset, the default value of the pointer register is 0, pointing to the temperature register.

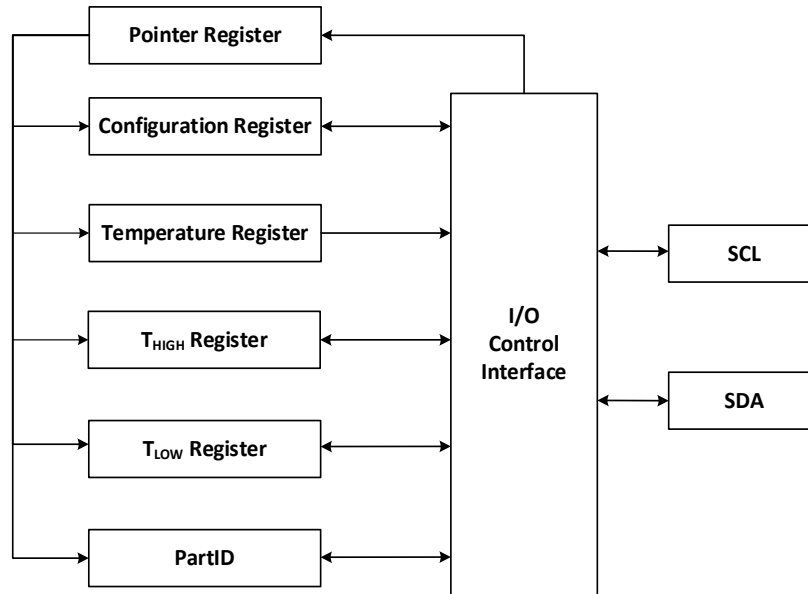

Figure 5.4. On-chip Register Structure

5.4.1. Pointer Register

The 8-bit pointer register is used to address a given data register, and the three LSBs of the pointer register determine which data register responds to a read or write operation by the master. The default value of pointer register after power on is "000", that is, the default state of the NST112 pointer register is the temperature register. [Table 5.6](#) identifies the bits of the pointer register byte. [Table 5.7](#) describes the pointer addresses of the registers available in the NST112.

Table 5.7. Pointer Register Byte

P7	P6	P5	P4	P3	P2	P1	P0
0	0	0	0	0	Pointer		

Table 5.8. Pointer Register Description

BIT No.	Name	Description
Bits 7:3	NA	P3 to P7 must always be 0 during the write command.
Bits 2:0	Pointer[2:0]	000: Temperature register (default) 001: Configuration register 010: T _{LOW} register 011: T _{HIGH} register 111: PartID register

5.4.2. Temperature Register

The temperature register is a read-only register used to store the results of each completed temperature conversion. The EM bit of the nst112 allows the sensor to be configured in normal mode or extended mode. In normal mode, the format of temperature register is 12 bits (HRES = 0) or 14 bits (HRES = 1). In extended mode, the format of temperature register is 13 bits (HRES = 0) or 15 bits (HRES = 1). The temperature register consists of 2 bytes in the format shown in table 5.8. The output code modes of the devices are described in detail in section [Resolution, High-Resolution Mode](#) and [Extended Mode](#).

Table 5.9. Temperature Register

Mode	D15	D14	D13	D12	D11	D10	D9	D8	D7	D6	D5	D4	D3	D2	D1	D0
12 Bits	T11	T10	T9	T8	T7	T6	T5	T4	T3	T2	T1	T0	0	0	0	0
13 Bits	(T12)	(T11)	(T10)	(T9)	(T8)	(T7)	(T6)	(T5)	(T4)	(T3)	(T2)	(T1)	(T0)	(0)	(0)	(0)
14 Bits	(T13)	(T12)	(T11)	(T10)	(T9)	(T8)	(T7)	(T6)	(T5)	(T4)	(T3)	(T2)	(T1)	(T0)	(0)	(0)
15 Bits	(T14)	(T13)	(T12)	(T11)	(T10)	(T9)	(T8)	(T7)	(T6)	(T5)	(T4)	(T3)	(T2)	(T1)	(T0)	(0)
Reset	0	0	0	0	0	0	0	0	0	0	0	0	0	0	0	0
	R	R	R	R	R	R	R	R	R	R	R	R	R	R	R	R

5.4.3. Configuration Register

The configuration register of the NST112 is a 16-bit read/write register used to store the control bits that control the NST112 into different operation modes, and the read/write operation is executed with MSB priority. [Table 5.9](#) lists the configuration register format, power-up and reset values. All registers are updated byte by byte. [Table 5.10](#) lists the configuration register Descriptions.

Table 5.10. Configuration and Power-Up/Reset Formats

D15	D14	D13	D12	D11	D10	D9	D8	D7	D6	D5	D4	D3	D2	D1	D0
OS	R1	R0	F1	F0	POL	NA	SD	CR1	CR0	AL	EM	NA	NA	HRES	NA
0	1	1	0	0	0	0	0	1	0	1	0	0	0	0	0
R/W	R/W	R/W	R/W	R/W	R/W	R/W	R/W	R/W	R/W	R	R/W	R/W	R/W	R/W	R/W

Table 5.11. Configuration register Description

BIT No.	Name	Description
Bit 15	OS	0: Continuous-Conversion Mode (default) 1: One-shot Mode
Bits 14:13	Converter Resolution [1:0]	When HRES Bit set 0, Converter Resolution Bits is active 00: 9bit (0.5 °C) 01: 10bit (0.25 °C) 10: 11bit (0.125 °C) 11: 12bit (0.0625 °C, default)
Bits 12:11	Fault Queue [1:0]	00: Consecutive faults are 1 (default) 01: Consecutive faults are 2 10: Consecutive faults are 4 11: Consecutive faults are 6
Bit 10	Polarity	0: AL bit is active low 1: AL bit is active High

BIT No.	Name	Description
Bit 9	NA	NA
Bit 8	Shutdown	0: Continuous-Conversion Mode (default) 1: Shutdown Mode
Bits 7:6	Conversion Rate	00: 0.25 Hz 01: 1 Hz 10: 4 Hz (default) 11: 8 Hz
Bit 5	Alert	Effective polarity depends on Bit10 0: ALERT 1: NO ALERT (default)
Bit 4	Extended Mode	0: Normal mode(default) 1: Extended Mode
Bit 3:2	NA	NA
Bit 1	High-Resolution	0: Resolution set by Bits 14:13 (default) 1: 14bit (0.015625 °C)
Bit 0	NA	NA

5.4.4. High and Low Limit Registers

The temperature limit values in the T_{HIGH} and T_{LOW} registers have the same format as the temperature values in the temperature registers, and the result is used to compare with the limit to determine the status of the AL bit at the completion of each temperature conversion. The MSB is sent first, followed by the LSB.

Power-up reset values for T_{HIGH} and T_{LOW} are:

T_{HIGH} = 80 °C and T_{LOW} = 75 °C

Table 5.12. T_{HIGH} Register

Mode	D15	D14	D13	D12	D11	D10	D9	D8	D7	D6	D5	D4	D3	D2	D1	D0
12 Bits	H11	H10	H9	H8	H7	H6	H5	H4	H3	H2	H1	H0	0	0	0	0
13 Bits	(H12)	(H11)	(H10)	(H9)	(H8)	(H7)	(H6)	(H5)	(H4)	(H3)	(H2)	(H1)	(H0)	(0)	(0)	(0)
14 Bits	(H13)	(H12)	(H11)	(H10)	(H9)	(H8)	(H7)	(H6)	(H5)	(H4)	(H3)	(H2)	(H1)	(H0)	(0)	(0)
15 Bits	(H14)	(H13)	(H12)	(H11)	(H10)	(H9)	(H8)	(H7)	(H6)	(H5)	(H4)	(H3)	(H2)	(H1)	(H0)	(0)
Reset	0	1	0	1	0	0	0	0	0	0	0	0	0	0	0	0
	R/W	R/W	R/W	R/W	R/W	R/W	R/W	R/W	R/W	R/W	R/W	R/W	R/W	R/W	R/W	R/W

Table 5.13. T_{LOW} Register

Mode	D15	D14	D13	D12	D11	D10	D9	D8	D7	D6	D5	D4	D3	D2	D1	D0
12 Bits	L11	L10	L9	L8	L7	L6	L5	L4	L3	L2	L1	L0	0	0	0	0
13 Bits	(L12)	(L11)	(L10)	(L9)	(L8)	(L7)	(L6)	(L5)	(L4)	(L3)	(L2)	(L1)	(L0)	(0)	(0)	(0)
14 Bits	(L13)	(L12)	(L11)	(L10)	(L9)	(L8)	(L7)	(L6)	(L5)	(L4)	(L3)	(L2)	(L1)	(L0)	(0)	(0)
15 Bits	(L14)	(L13)	(L12)	(L11)	(L10)	(L9)	(L8)	(L7)	(L6)	(L5)	(L4)	(L3)	(L2)	(L1)	(L0)	(0)
Reset	0	1	0	0	1	0	1	1	0	0	0	0	0	0	0	0

	R/W	R/W	R/W	R/W	R/W	R/W	R/W	R/W	R/W	R/W	R/W	R/W	R/W	R/W	R/W	R/W
--	-----	-----	-----	-----	-----	-----	-----	-----	-----	-----	-----	-----	-----	-----	-----	-----

5.4.5. Part ID Register

NST112 contains a read-only register of part ID. This register is a fixed value 0xA3A3. [Table 5.13](#) lists the part ID register format, power-up and reset values.

Table 5.14. Part ID Register

D15	D14	D13	D12	D11	D10	D9	D8	D7	D6	D5	D4	D3	D2	D1	D0
1	0	1	0	0	0	1	1	1	0	1	0	0	0	1	1
R	R	R	R	R	R	R	R	R	R	R	R	R	R	R	R

6. Typical Application

6.1. Noise Reduction

The NST112 is a micropower digital temperature sensor which lead to very low noise on the supply bus. Applying an RC filter to the VDD pin of the NST112 can further reduce any noise which can influence the performance of NST112. R_F in [Figure 6.1](#) should be less than $5k\Omega$ and C_F should be greater than $10nF$.

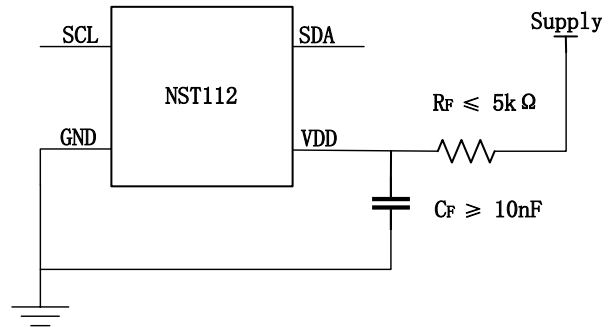

Figure 6.1 Noise Reduction

6.2. Typical Application Circuit

The NST112 is compatible with both SMBus and I²C interfaces. The NST112 has four slave addresses, allowing up to four NST112 devices on one bus. Although a bypass capacitor of $0.01\mu F$ is recommended. The sensing device for the NST112 device is the device itself. The thermal path is through the solder pads as well as the package. The low thermal resistance of the metal results in the pads providing the primary thermal path.

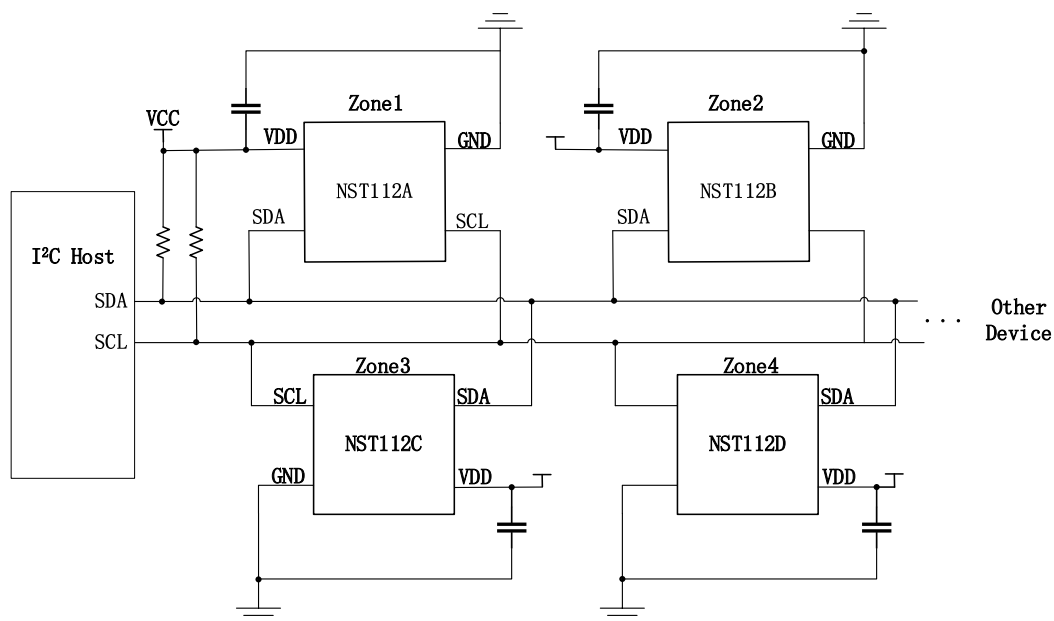

Figure 6. 2 Application Diagram

7. Package Information

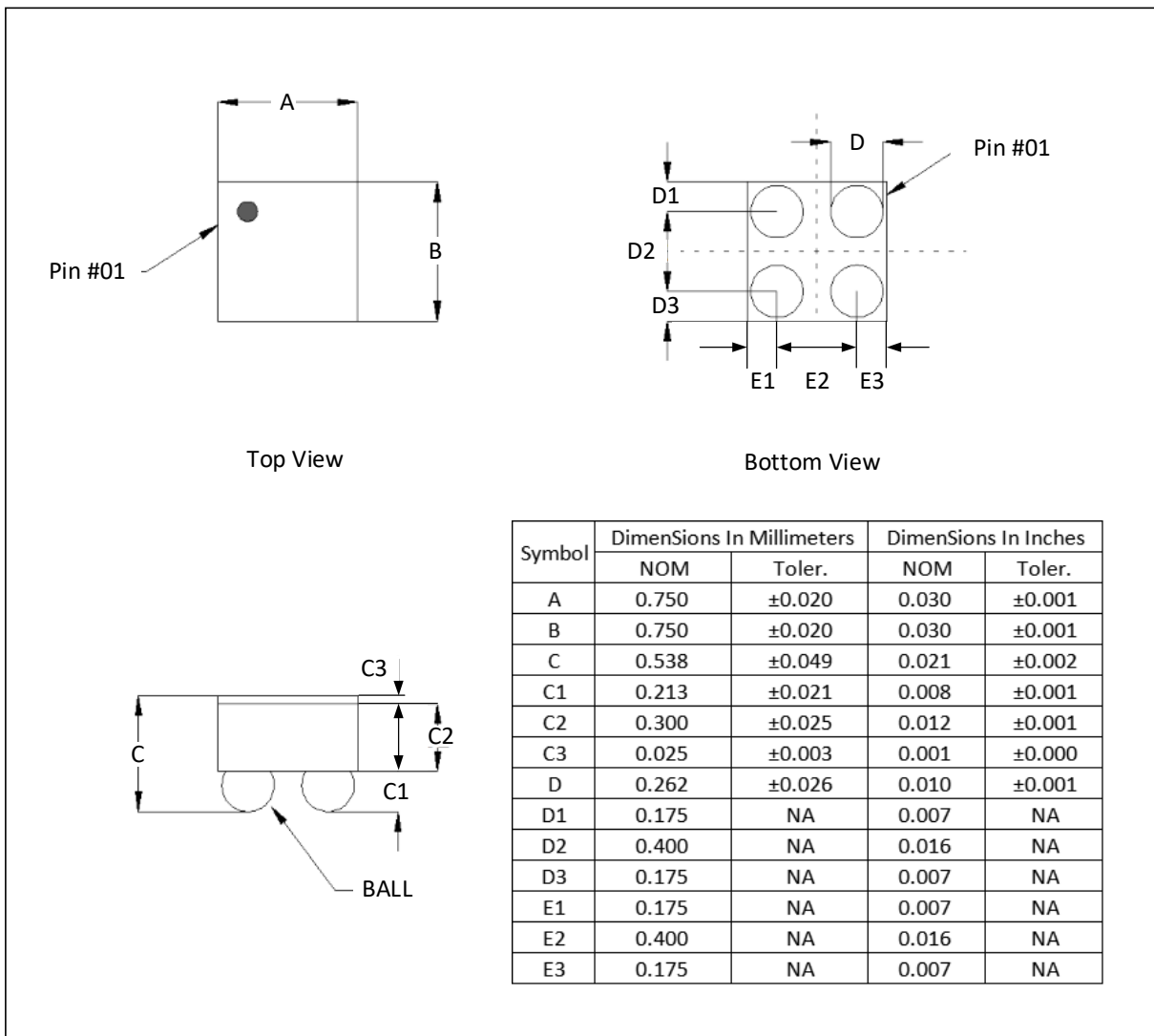
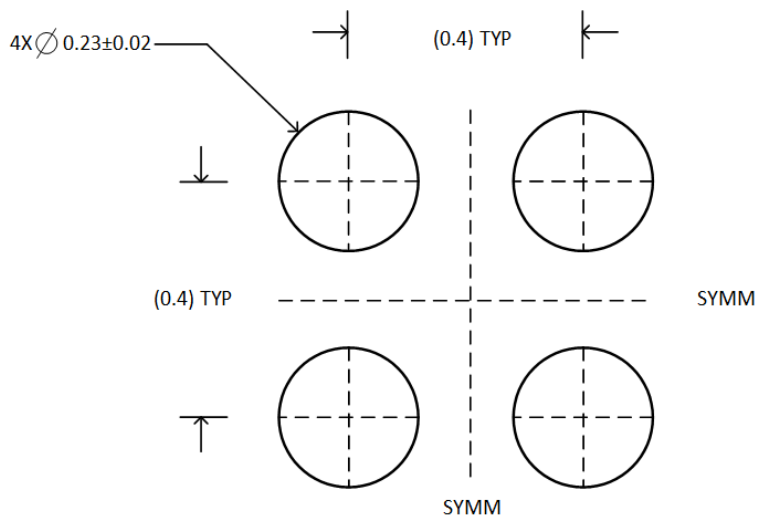
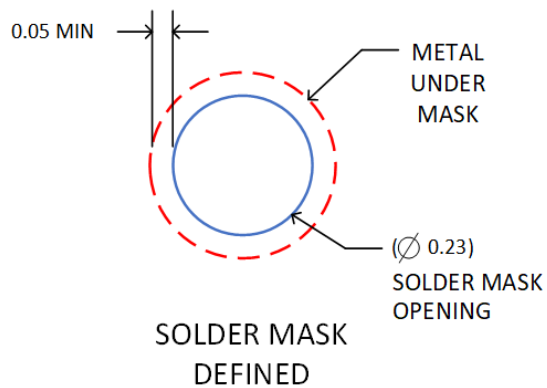
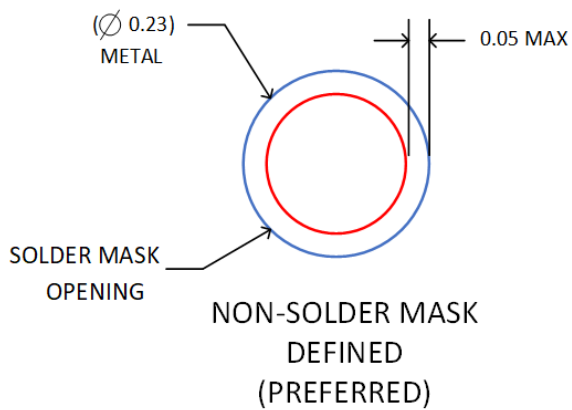

Figure 7.1. DSGBA-4 Package Shape and Dimension in millimeters and inches

8. Example Board Layout



LAND PATTERN EXAMPLE
SCALE:50X



SOLDER MASK DETAILS
NOT TO SCALE

9. Order Information

<i>Type</i>	<i>MSL</i>	<i>Unit</i>	<i>Marking^(1, 2)</i>	<i>Description</i>
NST112A-CWLR	1	3000ea/Reel	12A YWW	DSBGA-4 package, Reel
NST112B-CWLR	1	3000ea/Reel	12B YWW	DSBGA-4 package, Reel
NST112C-CWLR	1	3000ea/Reel	12C YWW	DSBGA-4 package, Reel
NST112D-CWLR	1	3000ea/Reel	12D YWW	DSBGA-4 package, Reel

(1) The marking relates to the logo, the lot trace code information.

(2) If a line is indented then it is a continuation of the previous line and the two combined represent the entire Device Marking for that device.

10. Marking

Type	Line	Name	Remark
	Line1	12A/12B/12C/12D	Product model
	Line2	YWW	Y:Year WW:week

11. Tape and Reel Information

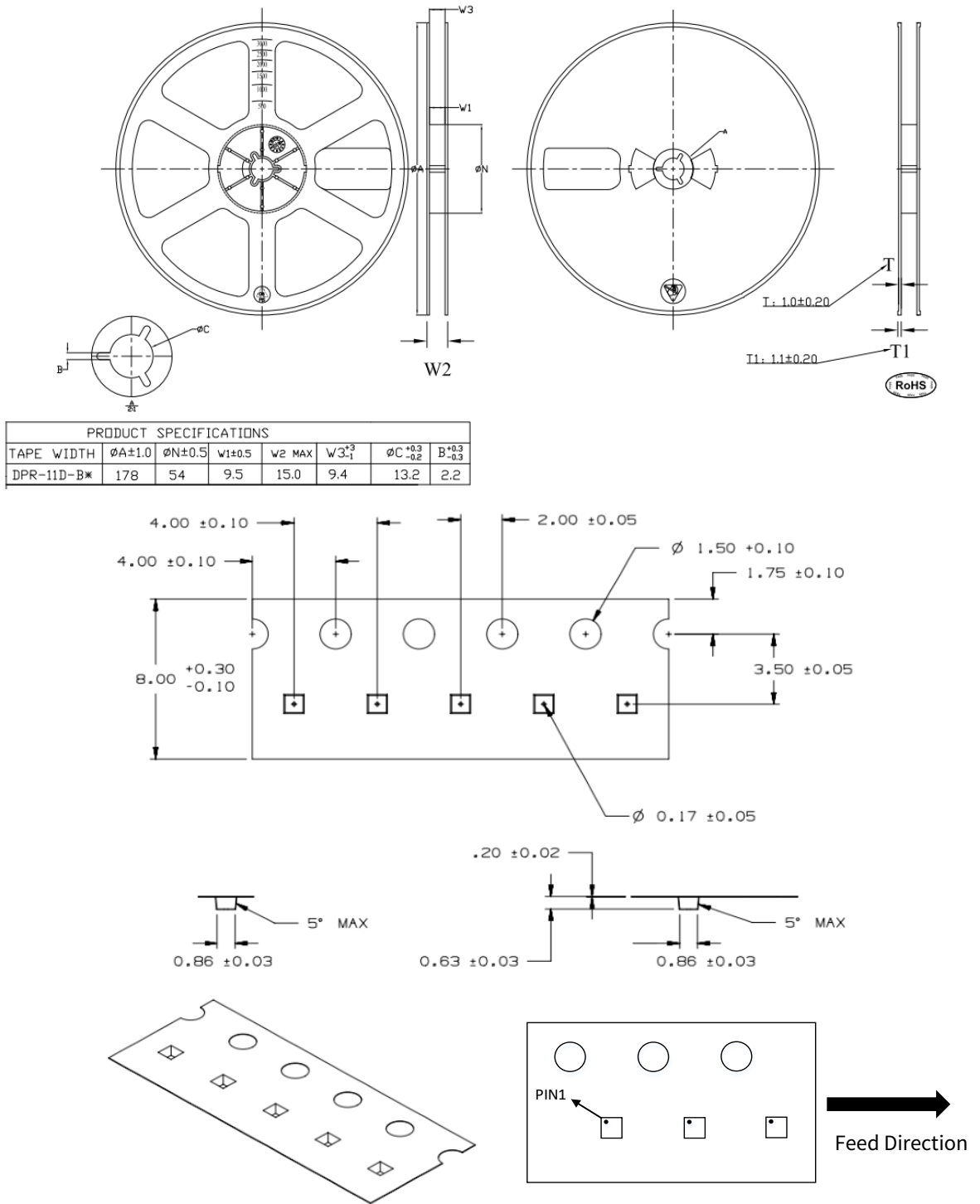

Figure 11.1. Tape and Reel Information of DSBGA (4)

12. Revision History

Revision	Description	Date
0.1	Initial Version	2020/04/16
0.9	Add DSBGA Package Information	2022/05/10
2.0	Modify Description Modify Electrical Characteristics Parameters Add Typical Characteristics Figs	2022/07/28
2.1	Modify Description Add Marking information	2023/02/13
2.2	Revise the Configuration Register Description Add Feed Direction and Example Board Layout	2024/04/24

IMPORTANT NOTICE

The information given in this document (the “Document”) shall in no event be regarded as any warranty or authorization of, express or implied, including but not limited to accuracy, completeness, merchantability, fitness for a particular purpose or infringement of any third party’s intellectual property rights.

Users of this Document shall be solely responsible for the use of NOVOSENSE’s products and applications, and for the safety thereof. Users shall comply with all laws, regulations and requirements related to NOVOSENSE’s products and applications, although information or support related to any application may still be provided by NOVOSENSE.

This Document is provided on an “AS IS” basis, and is intended only for skilled developers designing with NOVOSENSE’s products. NOVOSENSE reserves the rights to make corrections, modifications, enhancements, improvements or other changes to the products and services provided without notice. NOVOSENSE authorizes users to use this Document exclusively for the development of relevant applications or systems designed to integrate NOVOSENSE’s products. No license to any intellectual property rights of NOVOSENSE is granted by implication or otherwise. Using this Document for any other purpose, or any unauthorized reproduction or display of this Document is strictly prohibited. In no event shall NOVOSENSE be liable for any claims, damages, costs, losses or liabilities arising out of or in connection with this Document or the use of this Document.

For further information on applications, products and technologies, please contact NOVOSENSE (www.novosns.com).

Suzhou NOVOSENSE Microelectronics Co., Ltd