

Product Overview

NSPGS2E series are calibrated gauge pressure sensor which combines state-of-art MEMS sensor technology and CMOS mix-signal processing technology to produce an amplified, fully conditioned, multi-order pressure and temperature compensated sensor in a Small Outline Package (SOP) with tube port. NSPGS2E series pressure sensor is target for Auto and industrial application. Combining the pressure sensor with a signal conditioning ASIC in a single package simplifies the use of advanced silicon micromachined pressure sensors. The pressure sensor can be mounted directly to a standard printed circuit board and an amplified, high-level, calibrated pressure signal can be acquired from the digital interface or analog output. This eliminates the need for additional circuitry, such as a compensation network or micro-controller containing a custom correction algorithm. NSPGS2E series are designed for operating pressure ranges of -100kPa Gauge to 250kPa Gauge, very suitable for automotive applications such as seat pressure measurement and industrial pressure applications.

Key Features

- High accuracy
 - Total error band initially better than $\pm 1.5\%$ ($-40^{\circ}\text{C}\sim 115^{\circ}\text{C}$)
 - Full life accuracy better than $\pm 2.5\%$ ($-40^{\circ}\text{C}\sim 115^{\circ}\text{C}$)
- Large temperature range $-40^{\circ}\text{C}\sim 115^{\circ}\text{C}$
- 24bit I²C/SPI
- SOP package with air nozzle, easy to assembly
- RoHS & REACH Compliance
- AEC-Q100 qualified

Applications

- Automotive applications(seat pressure measurement)
- Industrial pressure sensor
- IoT pressure sensor

Device Information

Part Number	Package	Body Size
NSPGS2E	SOP6	7mm*7mm

Outline

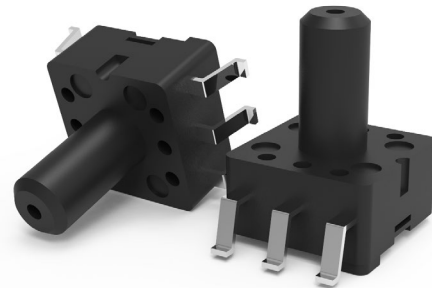

INDEX

1. PIN CONFIGURATION AND FUNCTIONS	3
2. ABSOLUTE MAXIMUM RATINGS	4
3. ESD RATINGS.....	4
4. RECOMMENDED OPERATING CONDITIONS	4
5. SPECIFICATIONS	5
5.1. ELECTRICAL CHARACTERISTIC	5
5.2. I ² C TIMING DIAGRAM.....	6
5.3. I ² C ELECTRICAL CHARACTERISTICS.....	6
5.4. SPI TIMING DIAGRAM.....	7
5.5. SPI ELECTRICAL CHARACTERISTICS	7
6. FUNCTION DESCRIPTION	8
6.1. OVERVIEW	8
6.2. DIGITAL OUTPUT TRANSFER FUNCTION.....	8
6.3. I ² C INTERFACE	9
6.4. SPI INTERFACE	12
7. TYPICAL APPLICATION.....	14
7.1. APPLICATION CIRCUIT	14
8. PACKAGE INFORMATION.....	15
8.1. PACKAGE SIZE	15
8.2. RECOMMENDED FOOTPRINT	15
9. ORDER INFORMATION.....	16
10. SOLDERING PARAMETERS	17
10.1. REFLOW SOLDERING (SMD TERMINAL)	17
10.2. MANUAL SOLDERING	17
11. PACKING INFORMATION	18
12. IDENTIFICATION CODE	18
13. REVISION HISTORY	20
NOTES:	21

1. Pin Configuration and Functions

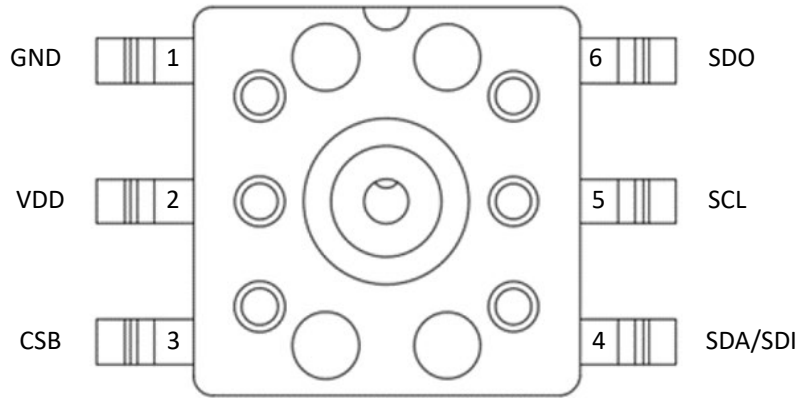

Figure 1.1 NSPGS2E Series Digital Output Pin Definition (Top view)

Table 1.1 Digital Output Pin Description

Pin NO.	Pin Name	Description
1	GND	Ground
2	VDD	Power supply
3	CSB	Chip select
4	SDA/SDI	Serial data input/output in I ² C mode (SDA)
		Serial data input in SPI mode (SDI)
5	SCL	Serial clock
6	SDO	Serial data output in SPI mode (SDO)

2. Absolute Maximum Ratings

Parameters	Symbol	Min	Typ	Max	Unit	Comments
Supply voltage	VDD	-0.3		6.5	V	
Digital pin voltage		-0.3		VDD+0.3	V	@25°C
Proof pressure	P _{proof}	300			kPa	
Burst pressure	P _{burst}	500		1000	kPa	
Storage temperature	T _{stg}	-40		125	°C	

3. ESD Ratings

Ratings		Value	Unit
Electrostatic discharge	Human body model (HBM), per AEC-Q100-002-RevE	±2	kV
	Charged device model (CDM), per AEC-Q100-011-RevD	±500	V

4. Recommended Operating Conditions

Parameters	Symbol	Min	Typ	Max	Unit	Comments
Supply voltage	VDD	3	3.3	3.6	V	
		4.5	5	5.5	V	
Operating pressure	P _{amb}	-100		250	kPa	
Operating pressure range	P _{range}	20		350	kPa	P _{max} - P _{min}
Operating temperature	T _{opr}	-40		115	°C	

5. Specifications

5.1. Electrical Characteristic

Parameters	Symbol	Min	Typ	Max	Unit	Comments
Operating Current	I_{avdd}		0.3	30	uA	Standby mode
ADC Resolution	RES_{RAW}		24		Bits	
PSRR	PSRR	90	120		dB	
Accuracy ^{1,2,3}	ACC	-1.5%		1.5%	%FS	Initially accuracy @-40°C~115°C
		-2.5%		2.5%	%FS	Full life accuracy @-40°C~115°C
Power up Time	T_{UP}		100		ms	
EEPROM Data Retention	T_{live}	10			years	@125°C

- Accuracy includes non-linearity, temperature, pressure hysteresis, temperature hysteresis.
- Full life accuracy based on the part number NSPGS2E170DT42 1000 hour HTOL, LTOL, THB and PCT testing.
- For pressure accuracy of different part number, please refer to complete part number list at chapter 9.

5.2. I²C Timing Diagram

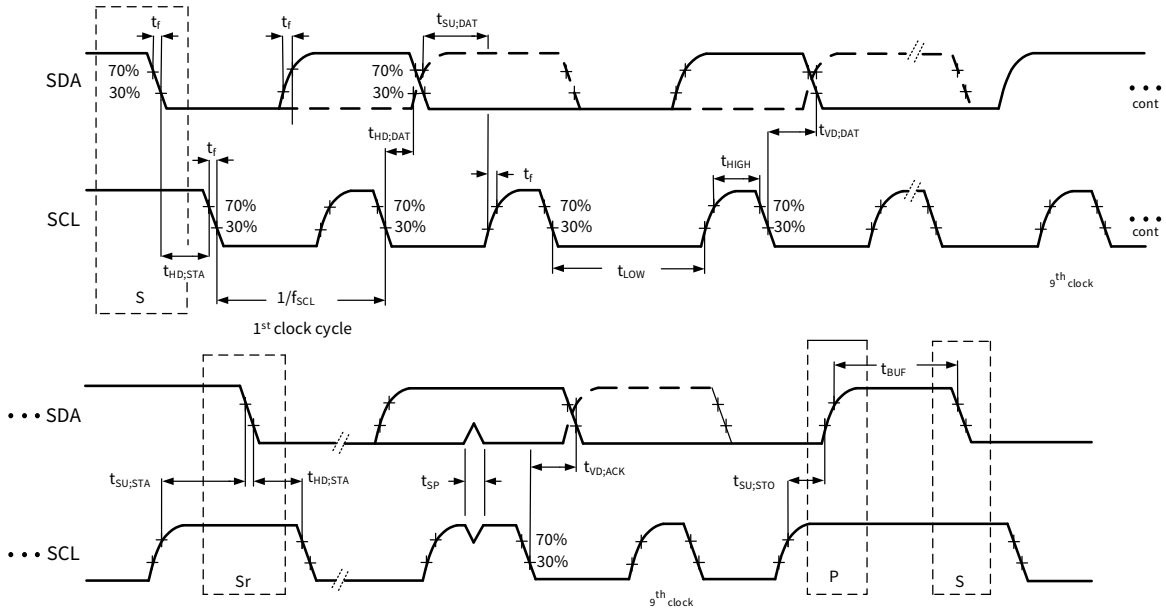

Figure 5.1 I²C Timing Diagram

5.3. I²C Electrical Characteristics

Parameters	Symbol	Min	Typ	Max	Unit	Comments
Clock frequency	f_{SCL}			400	kHz	
SCL low pulse	t_{LOW}	1.3			us	
SCL high pulse	t_{HIGH}	0.6			us	
SDA setup time	$t_{SU,DAT}$	0.1			us	
SDA hold time	$t_{HD,DAT}$	0.0			us	
Setup time for a repeated start condition	$t_{SU,STA}$	0.6			us	
Hold time for a start condition	$t_{HD,STA}$	0.6			us	
Setup time for a stop condition	$t_{SU,STO}$	0.6			us	
Time before a new transmission can start	t_{BUF}	1.3			us	

5.4. SPI Timing Diagram

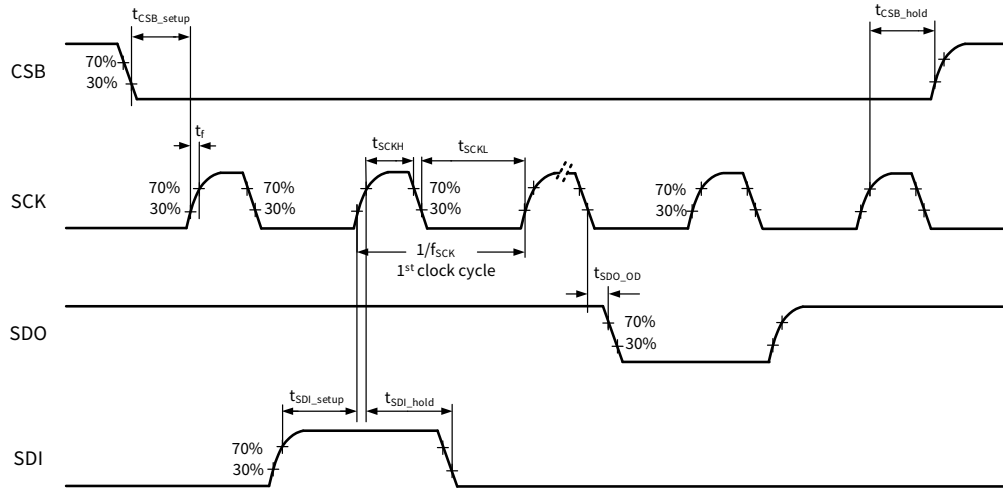

Figure 5.2 SPI Timing Diagram

5.5. SPI Electrical Characteristics

Parameters	Symbol	Min	Typ	Max	Unit	Comments
Clock frequency	f_{SCK}			10	MHz	Max load on SDI or SDO = 25pF
SLCK low pulse	t_{SCKL}	20			ns	
SLCK high pulse	t_{SCKH}	20			ns	
SDI setup time	t_{SDI_setup}	20			ns	
SDI hold time	t_{SDI_hold}	20			ns	
SDO/SDI output delay	t_{SDO_OD}			30	ns	Load = 25pF
				40	ns	Load = 250pF
CSB setup time	t_{CSB_setup}	20			ns	
CSB hold time	t_{CSB_hold}	40			ns	

6. Function Description

6.1. Overview

NSPGS2E uses a MEMS piezoresistive differential pressure sensor element as a pressure sensitive component that provide an original signal output that is proportional to ambient pressure. The built-in conditioning IC drives the sensitive component and amplifies, temperature compensates, and linearizes the original signal to output a voltage signal that is linear with the applied pressure.

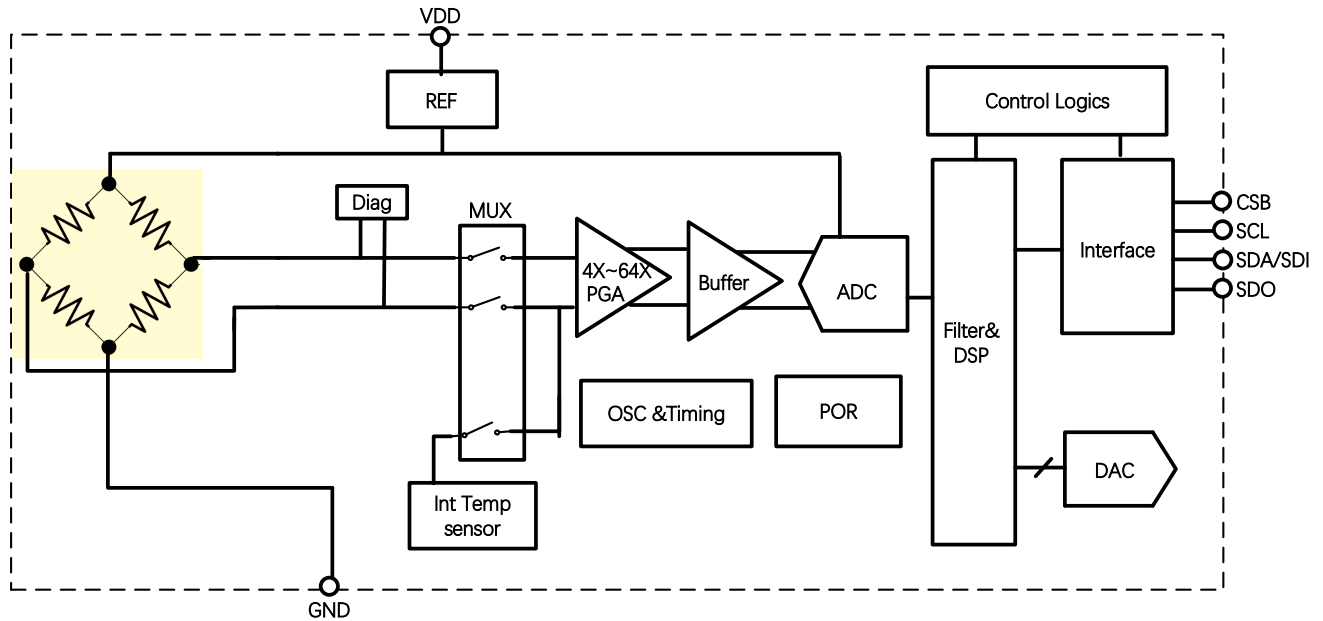

Figure 6.1 Product Function Block Diagram

6.2. Digital Output Transfer Function

$$Code = (A \times P + B) \times 8388607$$

Code is the register 0x06~0x08 value.

P is the pressure value, gauge pressure, unit is kPa.

Table 6.1 Digital Output Transfer Function Coefficient

Product Type	Pressure Range		Output Range		Gain and Offset	
	P _L	P _H	O _L	O _H	A	B
NSPGS2E170DT41	-50kPa	120kPa	838861	7549746	0.00471	0.33529

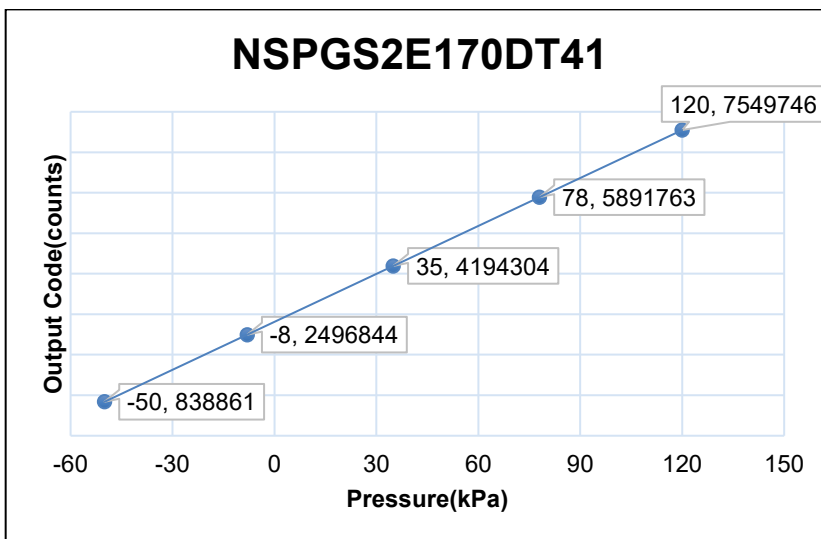

Figure 6.2 Digital Output Transfer Function

Register Map:

Addr	Bit Addr	Description	Default	Description
0x00	7,0	SDO_ACTIVE	1'b0 1'b0	Set either of these two bits to 1 for SPI-wire: 0: SPI 3-wire 1: SPI 4-wire (SDO as serial output)
	6 – 1	Reserve	6'b000000	
0x30	7 – 4	Reserve	4'b0000	Write with 0x0A to start a conversion, automatically come back to 0x02 after conversion ends.
	3	Sco	1'b0	
	2 – 0	Measurement_ctrl<2:0>	3'b000	
0x06	7 – 0	PDATA<23:16>	0x00	Output Pressure Data. Code = Data0x06*2 ¹⁶ + Data0x07*2 ⁸ + Data0x08;
0x07	7 – 0	PDATA<15:8>	0x00	
0x08	7 – 0	PDATA<7:0>	0x00	
0x6C	7 – 0	Reserve	0x02	Default value: 0x02.

For example:

If the value of the registers 0x06、0x07、0x08 are 0x2A、0xEA、0xEA, according to NSPGS2E170DT41 transfer function, Code = 2812651, P(kPa) = (2812650/8388607-B)/A, and finally get the value of pressure about 0kPa.

6.3. I²C Interface

I²C bus uses SCL and SDA as signal lines. Both lines are connected to VDD externally via pull-up resistors so that they are pulled high when the bus is free. The I²C device address of NSPGS2E is shown below.

Table 6.2 I²C Address

A7	A6	A5	A4	A3	A2	A1	W/R
1	1	1	1	1	1	1	0/1

The I²C interface protocol has special bus signal conditions. Start (S), stop (P) and binary data conditions are shown below. At start condition, SCL is high and SDA has a falling edge. Then the slave address is sent. After the 7 address bits,

the direction control bit R/W selects the read or write operation. When a slave device recognizes that it is being addressed, it should acknowledge by pulling SDA low in the ninth SCL (ACK) cycle.

At stop condition, SCL is also high, but SDA has a rising edge. Data must be held stable at SDA when SCL is high. Data can change value at SDA only when SCL is low.

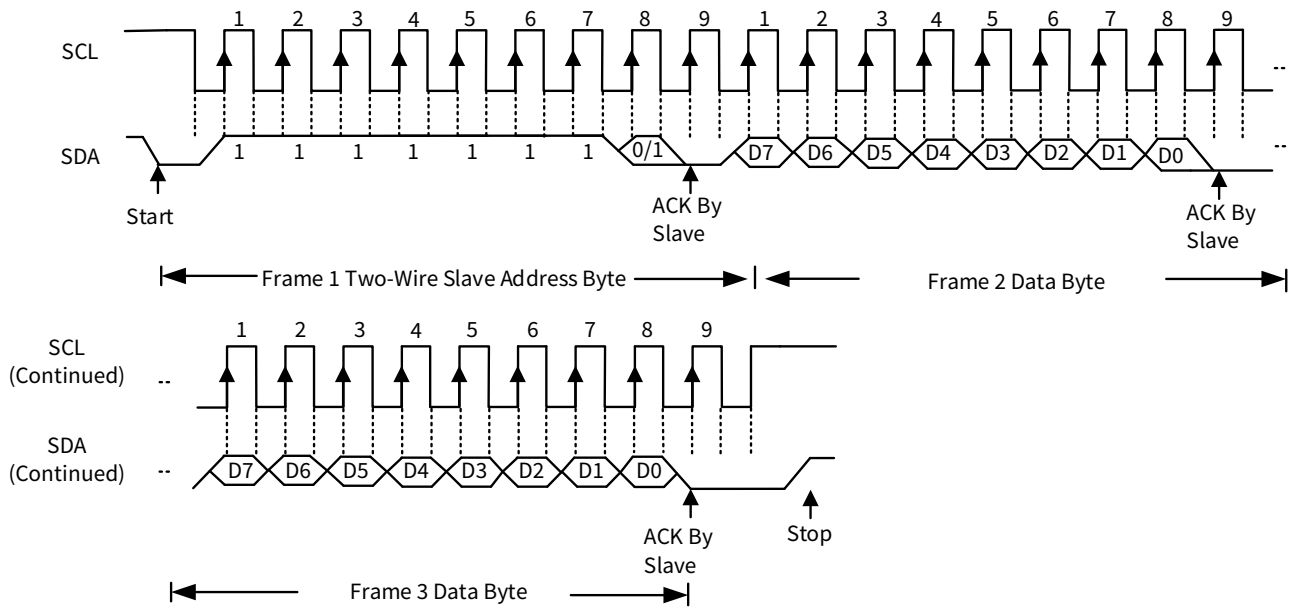

Figure 6.3 I²C Protocol

Byte Write

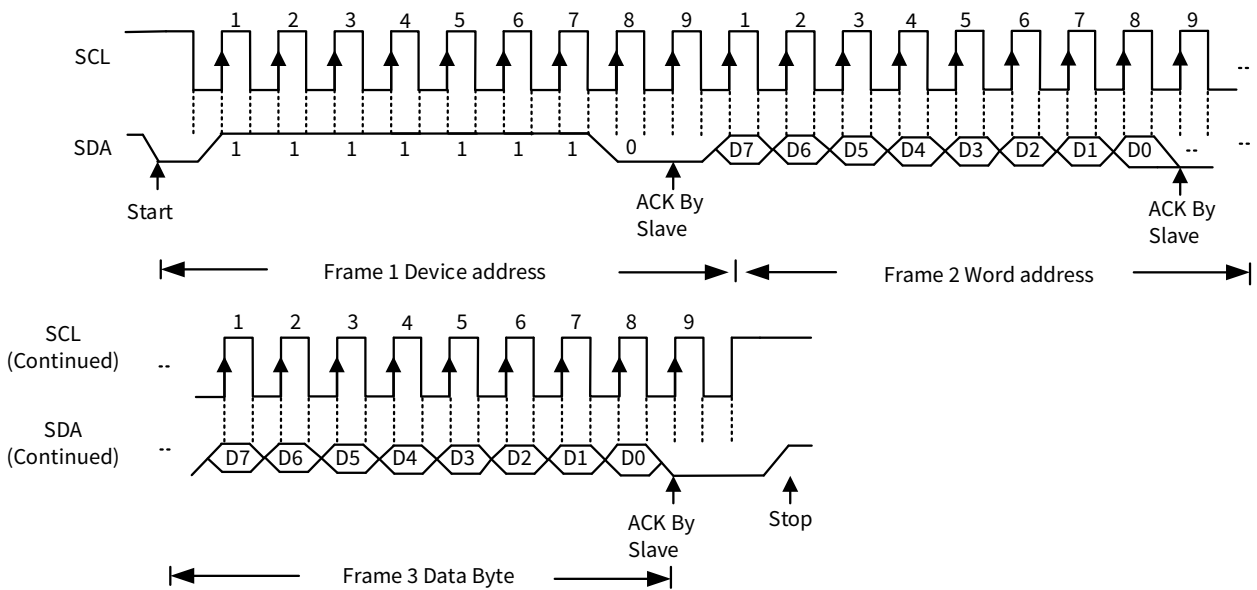

Figure 6.4 I²C Write Byte

Random Read

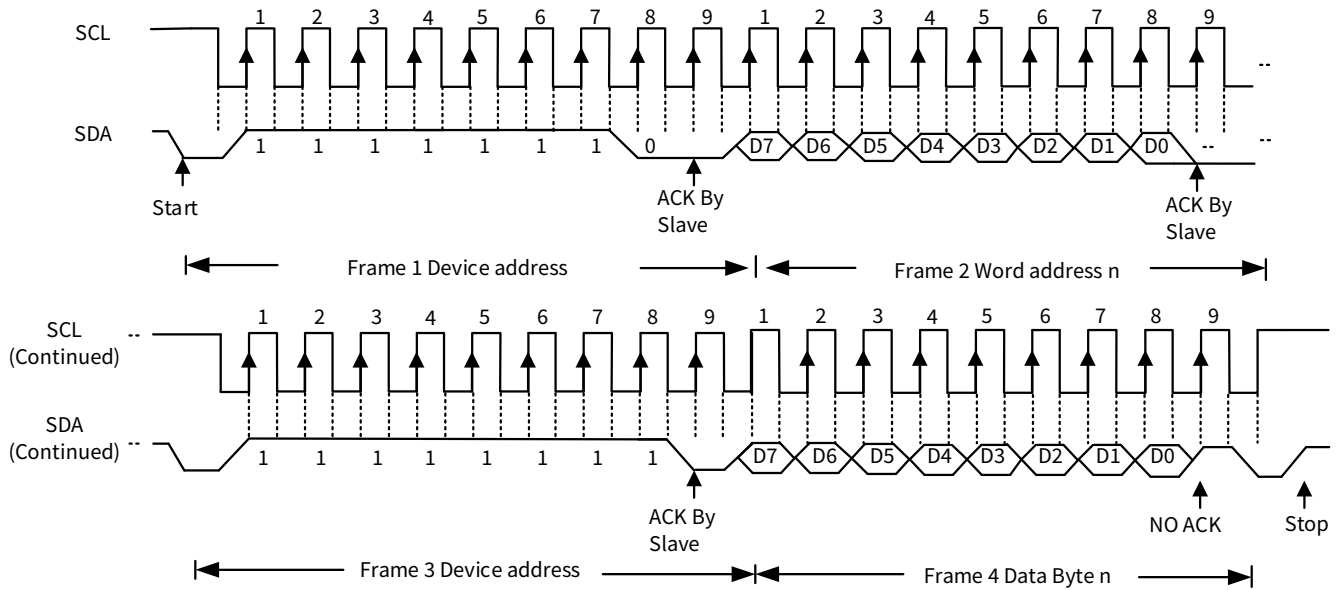

Figure 6.5 I²C Read Byte

6.4. SPI Interface

The falling edge of CSB, in conjunction with the rising edge of SCK, determines the start of framing. Once the beginning of the frame has been determined, timing is straightforward. The first phase of the transfer is the instruction phase, which consists of 16 bits followed by data that can be of variable lengths in multiples of 8 bits. If the device is configured with CSB tied low, framing begins with the first rising edge of SCK.

The instruction phase is the first 16 bits transmitted. As shown in Figure 6.6, the instruction phase is divided into a number of bit fields.

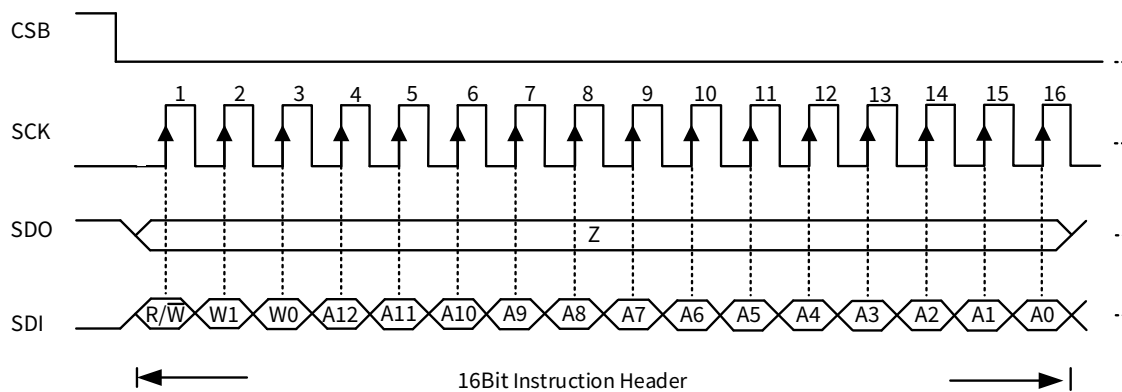

Figure 6.6 Instruction Phase Bit Field

The first bit in the stream is the read/write indicator bit (R/W). When this bit is high, a read is being requested, otherwise indicates it is a write operation.

W1 and W0 represent the number of data bytes to transfer for either read or write (Table 6.3). If the number of bytes to transfer is three or less (00, 01, or 10), CSB can stall high on byte boundaries. Stalling on a nonbyte boundary terminates the communications cycle. If these bits are 11, data can be transferred until CSB transitions high. CSB is not allowed to stall during the streaming process.

The remaining 13 bits represent the starting address of the data sent. If more than one word is being sent, sequential addressing is used, starting with the one specified, and it either increments (LSB first) or decrements (MSB first) based on the mode setting.

Table 6.3 W1 and W0 settings

W1:W0	Action	CSB Stalling
00	1 byte of data can be transferred.	Optional
01	2 bytes of data can be transferred.	Optional
10	3 bytes of data can be transferred.	Optional
11	4 or more bytes of data can be transferred. CSB must be held low for entire sequence; otherwise, the cycle is terminated.	No

Data follows the instruction phase. The amount of data sent is determined by the word length (Bit W0 and Bit W1). This can be one or more bytes of data. All data is composed of 8-bit words.

Data can be sent in either MSB-first mode or LSB-first mode (by setting 'LSB_first' bit). On power up, MSB-first mode is the default. This can be changed by programming the configuration register. In MSB-first mode, the serial exchange starts with the highest-order bit and ends with the LSB. In LSB-first mode, the order is reversed. (Figure 6.7)

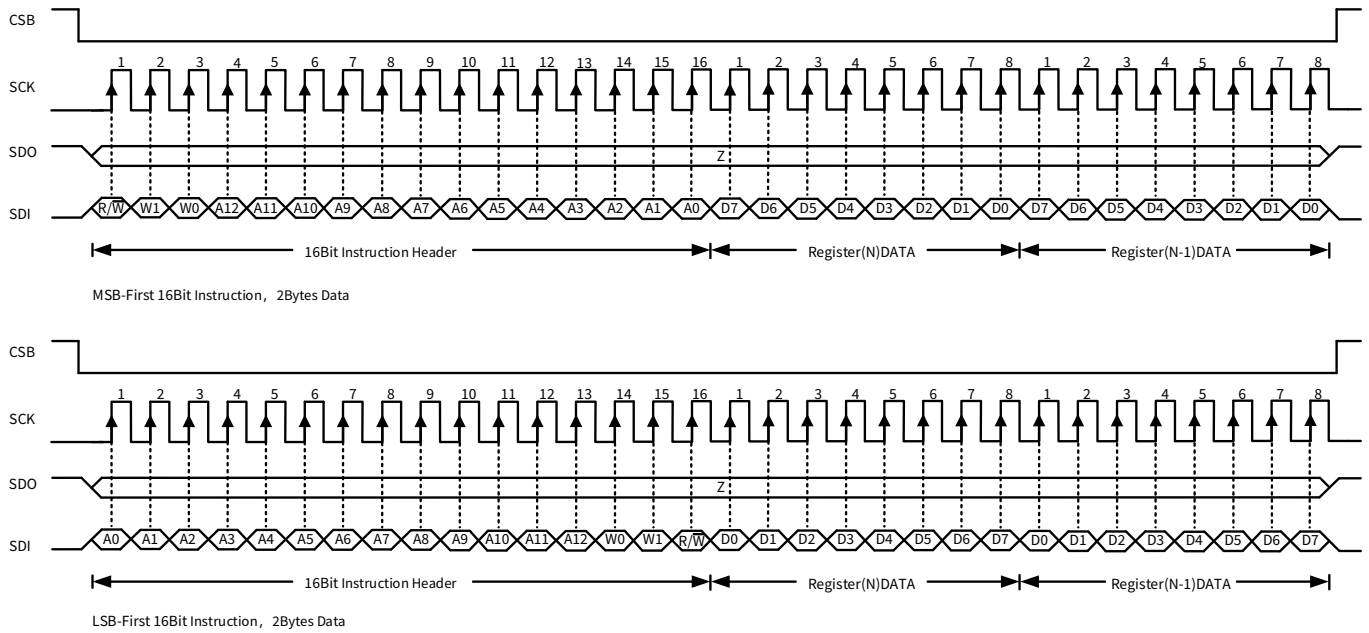

Figure 6.7 MSB First and LSB First Instruction and Data Phases

Byte Write

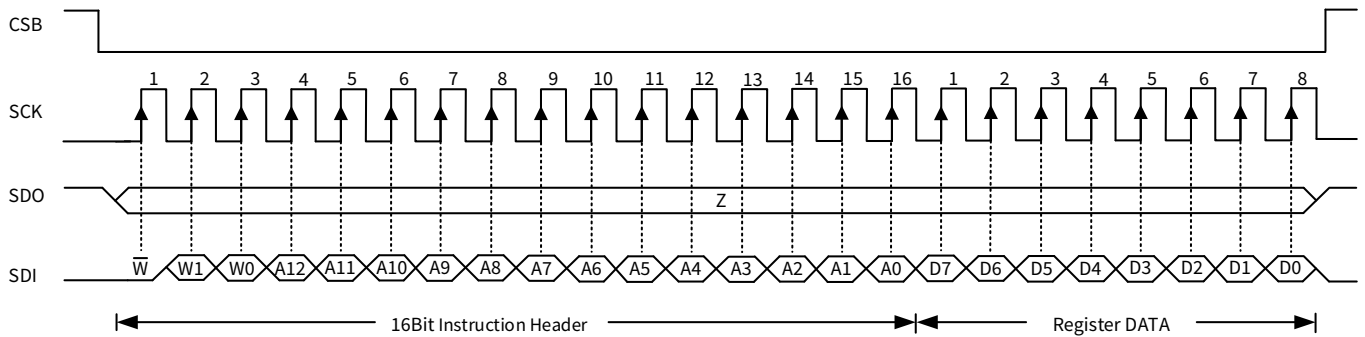

Figure 6.8 SPI Write Byte

Byte Read

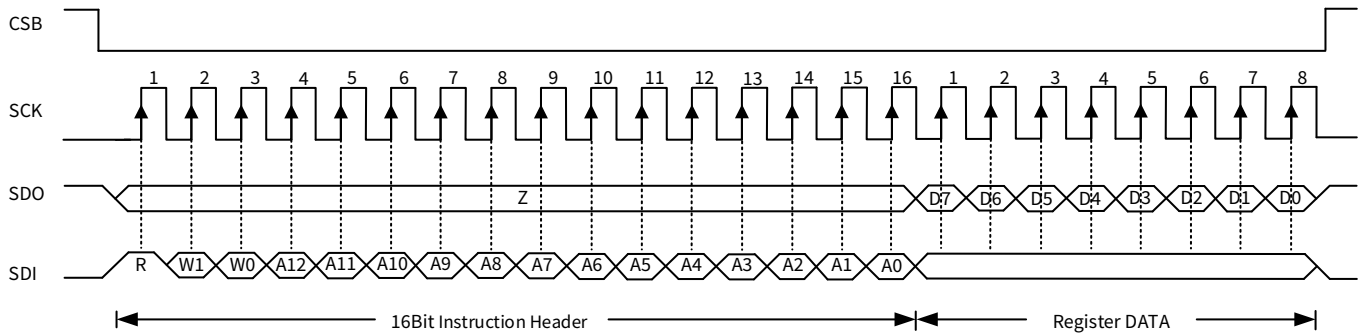

Figure 6.9 SPI Read Byte

7. Typical Application

7.1. Application Circuit

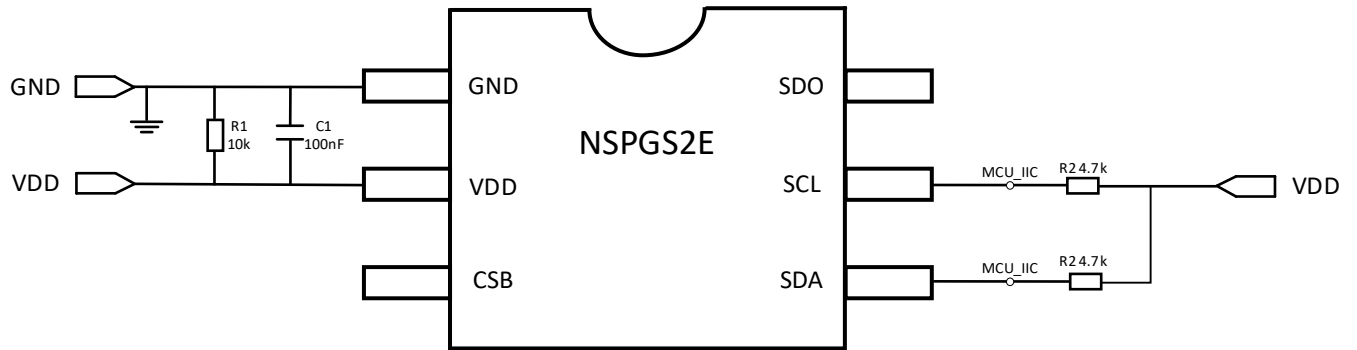

Figure 7.1 I²C Output Application Circuit

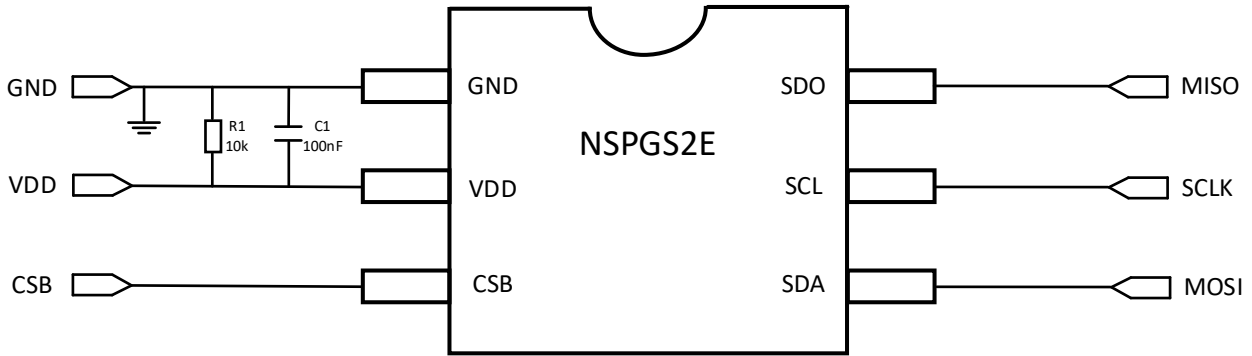

Figure 7.2 SPI Output Application Circuit

9. Order Information

Product Type	Output Type	Pressure Range		Output Range		Gain and Offset		Supply Voltage	Accuracy@-40~115°C	
		P_L	P_H	O_L	O_H	A	B		Initially	Full Life
NSPGS2E170DT41	I ² C/SPI	-50.00kPa	120.00kPa	838861	7549746	0.00471	0.33529	5.0V	±1.5%	±2.5%

Please scan the following QR code or visit the download link for complete part number list.

<https://www.novosns.com/Public/Uploads/uploadfile4/NSPGS2E.pdf>



Naming Convention:

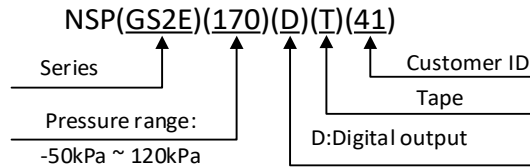

10. Soldering Parameters

10.1. Reflow Soldering (SMD Terminal)

Table 10.1 Soldering Parameters

<i>Reflow Condition</i>		<i>Lead-free Assembly</i>
Pre Heat	Temperature Min ($T_s(\min)$)	150°C
	Temperature Max ($T_s(\max)$)	200°C
	Time (min to max) (t_s)	60 – 180 secs
Average ramp up rate (Liquidus Temp (T_L) to peak)		3°C/second max
TS (max)to TL – Ramp-up Rate		3°C/second max
Reflow	Temperature (T_L) (Liquidus)	217°C
	Time (min to max) (t_L)	60 – 150 seconds
Peak Temperature (T_P)		260°C
Time within 5°C of actual peak Temperature (t_p)		20 – 40 seconds
Ramp-down Rate		6°C/second max
Time 25°C to peak Temperature (T_P)		8 minutes max
Do not exceed		260°C

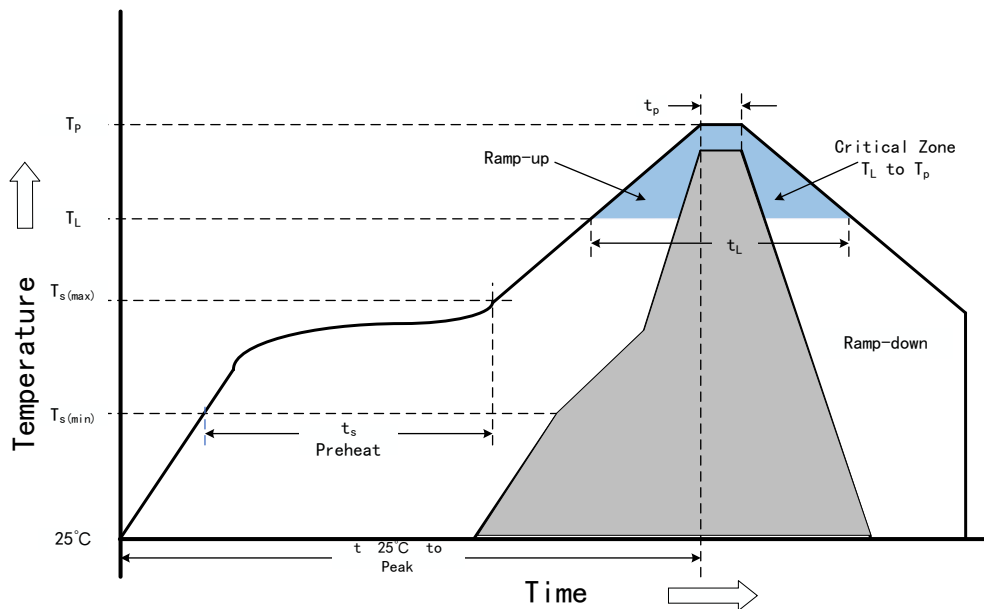
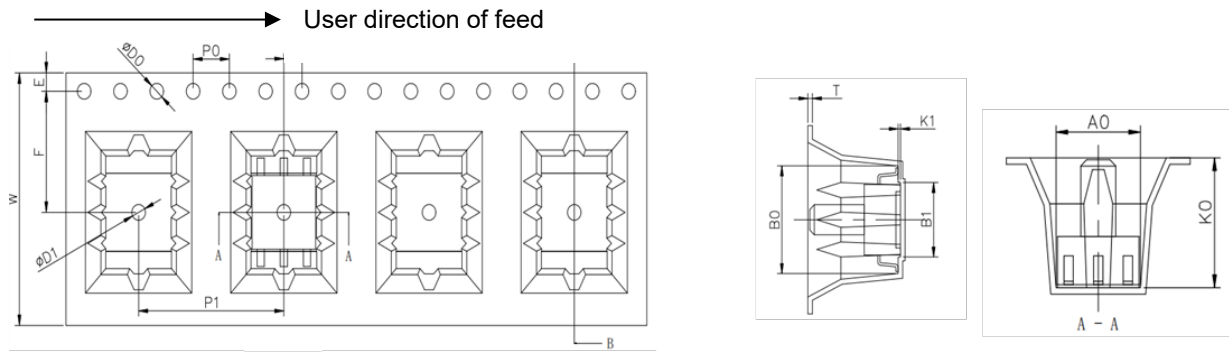

Figure 10.1 Reflow Soldering Curve

10.2. Manual Soldering

- Raise the temperature of the soldering tip between 260 °C and 300 °C and solder within 5 seconds.
- Use a flattened soldering tip when performing rework on the solder bridge.
- Complete rework in one time.

11. Packing Information



Part NO.	Package type	E(mm)	F(mm)	P2(mm)	D0(mm)	D1(mm)	P0(mm)	10P0(mm)	W(mm)	P1(mm)	A0(mm)	B0(mm)	B1(mm)	K0(mm)	K1(mm)	T(mm)
NSPGS2E	SOP6	1.75±0.10	11.50±0.10	2.00±0.10	1.50±0.1	1.50±0.1	4.00±0.1	40.00±0.20	24.00±0.3	16.00±0.1	7.20±0.1	10.70±0.10	7.40±0.10	10.15±0.10	0.25±0.10	0.50±0.05

There is no component at the head and tail of each tape, with a spacing of 10 spaces, as shown in the following figure.

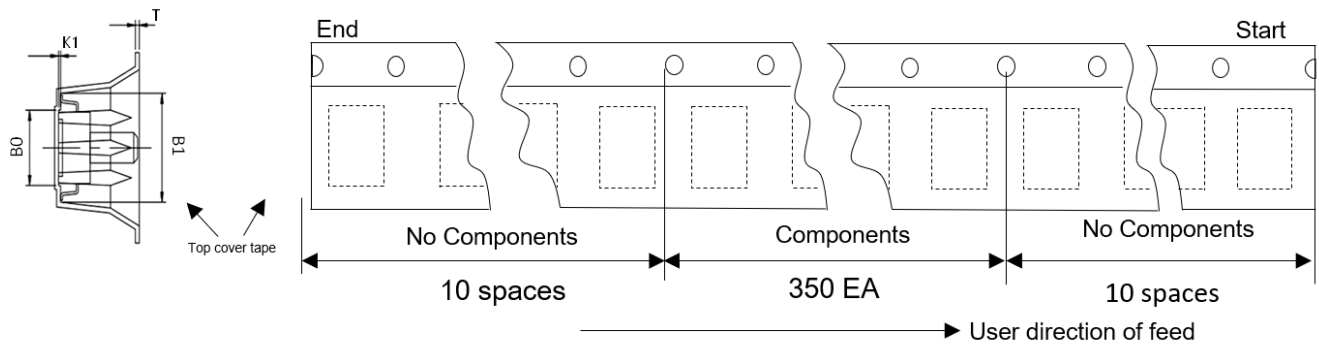

Pin1 is located at the third quadrant, as shown in the following figure.

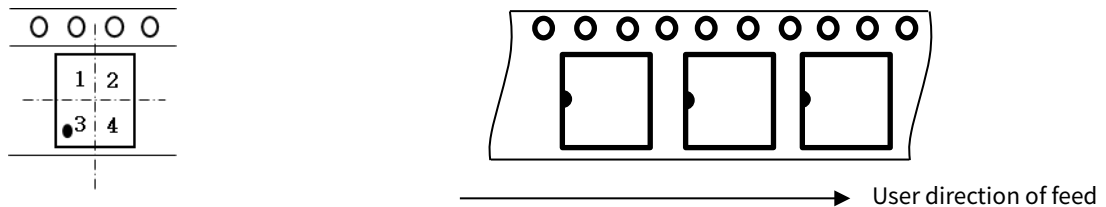

Standard pack quantity (SPQ): 350EA.

12. Identification Code

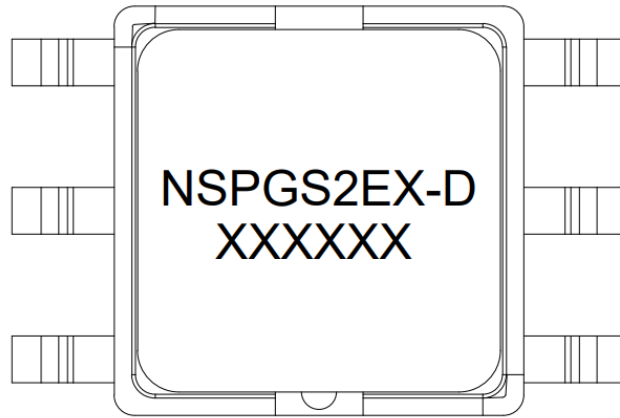

NSPGS2EX: Product series.

D: I²C/SPI

XXXXXX: Product serial number.

13. Revision History

Revision	Description	Date
1.0	Release Version.	2025/3/28
1.1	Update packing information.	2026/2/5

Notes:**1. I²C code**

```

#define ACK    1
#define NACK   0
uchar REG06=0,REG07=0,REG08=0;
uchar number=1;
uchar Reg30[1];
int PCode=0, Pdata=0;
float Pressure=0.0;
void IIC_Start(void)           //Start the IIC, SDA High-to-low when SCL is high
{
    IIC_SCL(1);                //SCL output high level
    SDA_OUT(1);                //SDA output high level
    Delay_us(2);               //Delay 2us
    SDA_OUT(0);                //SDA output low level
    Delay_us(2);
}

void IIC_Stop(void)           //Stop the IIC, SDA Low-to-high when SCL is high
{
    IIC_SCL(0);
    Delay_us(2);
    IIC_SCL(1);
    SDA_OUT(0);
    Delay_us(2);
    SDA_OUT(1);
    Delay_us(2);
}

void IIC_ACK(void)           //Send ACK (LOW)
{
    SDA_OUT(0);
    IIC_SCL(1);
    Delay_us(2);
    IIC_SCL(0);
}

void IIC_NACK(void)         //Send No ACK (High)
{
    SDA_OUT(1);
    IIC_SCL(1);
    Delay_us(2);
    IIC_SCL(0);
}

uchar IIC_Wait_ACK(void)     //Check ACK, if return 0, then right, if return 1, then error
{
    int ErrTime=0;
    SDA_IN();                  //SDA set as input
    IIC_SCL(1);
    Delay_us(2);
    while(Read_SDA)

```

```
{
    ErrTime++;
    if(ErrTime>200)
    {
        IIC_Stop();
        return 1;
    }
}
IIC_SCL(0);
SDA_OUT(0);
Delay_us(2);
return 0;
}

void IIC_Send(uchar IIC_Data)           //Send a byte to IIC
{
    uchar i;
    IIC_SCL(0);
    Delay_us(2);
    for(i=0;i<8;i++)
    {
        if((IIC_Data&0x80)>>7)
            SDA_OUT(1);
        else
            SDA_OUT(0);
        IIC_Data<<=1;
        IIC_SCL(1);
        Delay_us(2);
        IIC_SCL(0);
        Delay_us(2);
    }
}

uchar IIC_Receive(uchar ACK)           //Receive a byte from I2C
{
    uchar i,Receive_Data=0;
    SDA_IN();
    for(i=0;i<8;i++)
    {
        IIC_SCL(0);
        Delay_us(2);
        IIC_SCL(1);
        Receive_Data<<=1;
        if(Read_SDA==1)
            Receive_Data++;
        Delay_us(2);
    }
    IIC_SCL(0);
    Delay_us(2);
    if(ACK==0x01)
        IIC_ACK();
    else
        IIC_NACK();
    return Receive_Data;
}
```

```
}

void NSPGS2E170DT41_Write_Byte(uchar WriteAddr,uchar WriteData)
{
    IIC_Start();
    IIC_Send(0xFE|0x00);
    IIC_Wait_ACK();
    IIC_Send(WriteAddr);
    IIC_Wait_ACK();
    IIC_Send(WriteData);
    IIC_Wait_ACK();
    IIC_Stop();
}

void NSPGS2E170DT41_Read_Byte(uchar ReadAddr, uchar *pBuffer)
{
    IIC_Start();
    IIC_Send(0xFE|0x00);
    IIC_Wait_ACK();
    IIC_Send(ReadAddr);
    IIC_Wait_ACK();
    IIC_Start();
    IIC_Send(0xFE|0x01);
    IIC_Wait_ACK();
    pBuffer[0]=IIC_Receive(0);
    IIC_Stop();
}

void NSPGS2E170DT41_Read_3Byte(uchar ReadAddr,uchar *pBuffer)
{
    IIC_Start();
    IIC_Send(0xFE|0x00);
    IIC_Wait_ACK();
    IIC_Send(ReadAddr);
    IIC_Wait_ACK();
    IIC_Start();
    IIC_Send(0xFE|0x01);
    IIC_Wait_ACK();
    pBuffer[0]=IIC_Receive(ACK);
    pBuffer[1]=IIC_Receive(ACK);
    pBuffer[2]=IIC_Receive(NACK);
    IIC_Stop();
}

void main()
{
    uchar PData[3]={0,0,0};
    while(1)
    {
        NSPGS2E170DT41_Write_Byte(0x30,0x0A);
        while(1) //Check whether the conversion ends
        {
            if(number<=50)
            {
```

```

        number++;
        delay_ms(1);
        NSPGS2E170DT41_Read_Byte(0x30,Reg30);
        if(0x02==Reg30[0])
        {
            number=1;
            break;
        }
    }
    if(number>50)
    {
        number=1;
        //User can add his own error handler function
        break;
    }
}
NSPGS2E170DT41_Read_3Byte(0x06,PData);
REG06 = PData [0];           //Register 0x06
REG07 = PData [1];           //Register 0x07
REG08 = PData [2];           //Register 0x08
PCode=(REG06*65536+REG07*256+REG08); //PCode = Data0x06*2^16+ Data0x07*2^8+
Data0x08
if (PCode >8388607)
    Pdata= PCode-16777216;           //Symbol processing
else
    Pdata= PCode;
Pressure =((float)Pdata/8388607-0.33529)/0.00471; //PCode=(AxP+B)*8388607
P=(PCode/8388607-B)/A
//A=0.00471, B=0.33529
//PNormalized=PCode/8388607
}
}

```

2. SPI code

```
u8 REG06=0,REG07=0,REG08=0;
u8 number=1;
u8 PData[3]={0};
u32 PCode=0,Pdata=0;
float Pressure=0.0;
void NSPGS2E170DT41_SPI_Init(void)
{
    SPI_PORT_GPIO_Config();
    CSB(1);
    SCLK(0);
    SDI(1);
}

void NSPGS2E170DT41_SPI_Write_OneByte(u8 addr,u8 val)
{
    u8 i=0; u16 dat;

    dat=0x0000+addr;
    CSB(0);
    delay_us(2);

    for(i=0;i<16;i++)
    {
        SCLK(0);
        if(dat&0x8000)
            SDI(1);
        else
            SDI(0);
        delay_us(2);
        dat<<=1;
        SCLK(1);
        delay_us(2);
    }

    for(i=0;i<8;i++)
    {
        SCLK(0);
        if(val&0x80)
            SDI(1);
        else
            SDI(0);
        delay_us(2);
        val<<=1;
        SCLK(1);
        delay_us(2);
    }

    SCLK(0);
    CSB(1);
    delay_us(2);
}

u8 NSPGS2E170DT41_SPI_Read_OneByte(u8 addr)
{
    u8 i=0; u16 dat; u8 val=0;

    dat=0x8000+addr;
    CSB(0);
    delay_us(2);
```

```
for(i=0;i<16;i++)
{
    SCLK(0);
    if(dat&0x8000)
    {
        SDI(1);
    }
    else
    {
        SDI(0);
    }
    delay_us(2);
    dat <<= 1;
    SCLK(1);
    delay_us(2);
}

for(i=0;i<8;i++)
{
    SCLK(0);
    val<<=1;
    if(SPI_MISO)
        val++;
    delay_us(2);
    SCLK(1);
    delay_us(2);
}

SCLK(0);
CSB(1);
delay_us(2);

return val;
}

void NSPGS2E170DT41_SPI_Read_3Byte(u8 addr,u8* pBuffer)
{
    u8 i=0; u16 dat; u8 val_1=0,val_2=0,val_3=0;

    dat=0xC000+addr;
    CSB(0);
    delay_us(2);

    for(i=0;i<16;i++)
    {
        SCLK(0);
        if(dat&0x8000)
        {
            SDI(1);
        }
        else
        {
            SDI(0);
        }
        delay_us(2);
        dat <<= 1;
        SCLK(1);
        delay_us(2);
    }

    for(i=0;i<8;i++)
```

```
{
    SCLK(0);
    val_1<<=1;
    if(SPI_MISO) val_1++;
    delay_us(2);
    SCLK(1);
    delay_us(2);
}

for(i=0;i<8;i++)
{
    SCLK(0);
    val_2<<=1;
    if(SPI_MISO) val_2++;
    delay_us(2);
    SCLK(1);
    delay_us(2);
}

for(i=0;i<8;i++)
{
    SCLK(0);
    val_3<<=1;
    if(SPI_MISO) val_3++;
    delay_us(2);
    SCLK(1);
    delay_us(2);
}
pBuffer[0]=val_1;
pBuffer[1]=val_2;
pBuffer[2]=val_3;

SCLK(0);
CSB(1);
delay_us(2);
}

void NSPGS2E170DT41_SPI_Read_MultiByte(u8 addr,u8 len,u8 *pBuffer)
{
    u8 i=0,k=0,val=0; u16 dat;

    dat=0xE000+addr;
    CSB(0);
    delay_us(2);

    for(i=0;i<16;i++)
    {
        SCLK(0);
        if(dat&0x8000)
        {
            SDI(1);
        }
        else
        {
            SDI(0);
        }
        delay_us(2);
        dat <<= 1;
        SCLK(1);
        delay_us(2);
    }
    for(k=0;k<len;k++)
```

```

    {
        for(i=0;i<8;i++)
        {
            SCLK(0);
            val<<=1;
            if(SPI_MISO)val++;
            delay_us(2);
            SCLK(1);
            delay_us(2);
        }
        pBuffer[k]=val;
    }

    SCLK(0);
    CSB(1);
    delay_us(2);
}

int main(void)
{
    NSPGS2E170DT41_SPI_Init();
    delay_ms(100);
    NSPGS2E170DT41_SPI_Write_OneByte(0x00,0x81);

    while(1)
    {
        NSPGS2E170DT41_SPI_Write_OneByte(0x30,0x0A);
        while(1) //Check whether the conversion ends
        {
            if(number<=50)
            {
                number++;
                delay_ms(1);
                if(0x02== NSPGS2E170DT41_SPI_Read_OneByte(0x30))
                {
                    number=1;
                    break;
                }
            }
            if(number>50)
            {
                number=1;
                break;
            }
        }
        NSPGS2E170DT41_SPI_Read_3Byte(0x08,PData);
        REG08=PData[0]; //Register 0x08
        REG07=PData[1]; //Register 0x07
        REG06=PData[2]; //Register 0x06
        PCode=(REG06*65536+REG07*256+REG08); //PCode = Data0x06*2^16+ Data0x07*2^8+ Data0x08

        if (PCode>8388607)
            Pdata=PCode-16777215; //Symbol processing
        else Pdata=PCode;
        Pressure=((float)Pdata/8388607-0.33529)/0.00471; //PCode=(AxP+B)*8388607 P=(PCode/8388607-B)/A
        //A=0.00471, B=0.33529
        //PNormalized=PCode/8388607
    }
}

```

IMPORTANT NOTICE

The information given in this document (the “Document”) shall in no event be regarded as any warranty or authorization of, express or implied, including but not limited to accuracy, completeness, merchantability, fitness for a particular purpose or infringement of any third party’s intellectual property rights.

Users of this Document shall be solely responsible for the use of NOVOSENSE’s products and applications, and for the safety thereof. Users shall comply with all laws, regulations and requirements related to NOVOSENSE’s products and applications, although information or support related to any application may still be provided by NOVOSENSE.

This Document is provided on an “AS IS” basis, and is intended only for skilled developers designing with NOVOSENSE’s products. NOVOSENSE reserves the rights to make corrections, modifications, enhancements, improvements or other changes to the products and services provided without notice. NOVOSENSE authorizes users to use this Document exclusively for the development of relevant applications or systems designed to integrate NOVOSENSE’s products. No license to any intellectual property rights of NOVOSENSE is granted by implication or otherwise. Using this Document for any other purpose, or any unauthorized reproduction or display of this Document is strictly prohibited. In no event shall NOVOSENSE be liable for any claims, damages, costs, losses or liabilities arising out of or in connection with this Document or the use of this Document.

For further information on applications, products and technologies, please contact NOVOSENSE (www.novosns.com).

Suzhou NOVOSENSE Microelectronics Co., Ltd