

### Product Overview

The NSOPA901x-Q1 family (NSOPA9011, NSOPA9012, and NSOPA9014) is a family of high voltage (40 V) general purpose operational amplifiers. These devices offer exceptional DC precision and AC performance, including rail-to-rail input/output, low offset ( $\pm 300 \mu\text{V}$ , typical), low offset drift ( $\pm 1.8 \mu\text{V}/^\circ\text{C}$ , typical), low noise (22 nV/ $\sqrt{\text{Hz}}$  and 14  $\mu\text{VPP}$ ), and 6MHz bandwidth. Unique features such as differential and common-mode input-voltage range to the supply rail, high output current (55mA), high slew rate (2V/ $\mu\text{s}$ ), high capacitive load drive (1nF), and shutdown functionality make the NSOPA901x-Q1 a robust, high performance operational amplifier for high-voltage industrial applications.

The NSOPA901x-Q1 family of op amps is available in standard packages (SOT-23, MSOP, SOP, and TSSOP), and is specified from  $-40^\circ\text{C}$  to  $125^\circ\text{C}$ .

### Key Features

- Optimized for AEC-Q100 grade1 application
- Wide supply:  $\pm 1.35 \text{ V}$  to  $\pm 20 \text{ V}$ , 2.7 V to 40 V
- Low offset voltage: 300 $\mu\text{V}$  typ
- 1 MHz GBP
- High slew rate: 2 V/ $\mu\text{s}$  typ
- Differential and common-mode input voltage range to supply rail Pulse friendly/comparator inputs
  1. Amplifier operates with differential inputs up to supply rail
  2. Amplifier can be used in open-loop or as comparator
- Low quiescent current: 145  $\mu\text{A}$  per amplifier
- Robust EMIRR performance: EMI/RFI filters on input and supply pins
- RoHS and REACH compliance

### Device Information

Part Number	Package	Body Size
NSOPA9011-Q1STAR	SOT23-5L	2.90 mm × 1.60 mm
NSOPA9011-Q1SPR	SOP8	4.90 mm × 3.90 mm
NSOPA9012-Q1SPR	SOP8	4.90 mm × 3.90 mm
NSOPA9012-Q1MSR	MSOP8	3.00 mm × 3.00 mm
NSOPA9014-Q1SPKR	SOP14	8.65 mm × 3.9 mm
NSOPA9014-Q1TSKR	TSSOP14	5.00 mm × 4.40 mm

### Typical Application

- Infotainment and cluster
- Advanced driver assistance systems (ADAS)
- Powertrain current sensor
- On-board (OBC) and wireless charge
- HEV/EV inverter and motor control
- High-side and low-side current sensing

## INDEX

1. PIN CONFIGURATION AND FUNCTIONS .....	3
2. ABSOLUTE MAXIMUM RATINGS .....	6
3. ESD RATINGS.....	6
4. RECOMMENDED OPERATING CONDITIONS .....	6
5. THERMAL INFORMATION.....	6
6. ELECTRICAL CHARACTERISTICS.....	7
7. TYPICAL PERFORMANCE CHARACTERISTICS.....	10
8. FUNCTION DESCRIPTION .....	17
8.1. OVERVIEW .....	17
8.2. FUNCTIONAL BLOCK DIAGRAM .....	17
8.3. FEATURE DESCRIPTION.....	17
8.3.1. PULSE FRIENDLY .....	17
8.3.2. SLEW RATE BOOST.....	18
8.3.3. COMMON-MODE INPUT STAGE .....	18
8.3.4. EMI REJECTION .....	19
8.3.5. DRIVE CAPACITIVE LOAD.....	19
8.3.6. THERMAL PROTECTION .....	20
8.3.7. ELECTRICAL OVERSTRESS .....	20
9. APPLICATION .....	22
9.1. ACTIVE FILTER.....	22
9.2. HIGH-SIDE CURRENT SENSING.....	23
10. LAYOUT GUIDANCE.....	24
10.1. GUIDELINES.....	24
10.2. EXAMPLE.....	24
11. PACKAGE INFORMATION.....	25
11.1. SOT23-5L .....	25
11.2. SOP8.....	26
11.3. MSOP8.....	27
11.4. SOP14.....	28
11.5. TSSOP14 .....	29
12. ORDERING INFORMATION .....	30
13. TAPE AND REEL INFORMATION.....	31
14. REVISION HISTORY.....	32

### 1. Pin Configuration and Functions

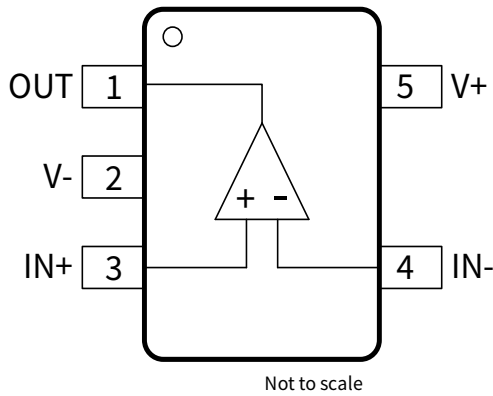

Figure 1-1 NSOPA9011-Q1 5-Pin SOT-23 Package Top View

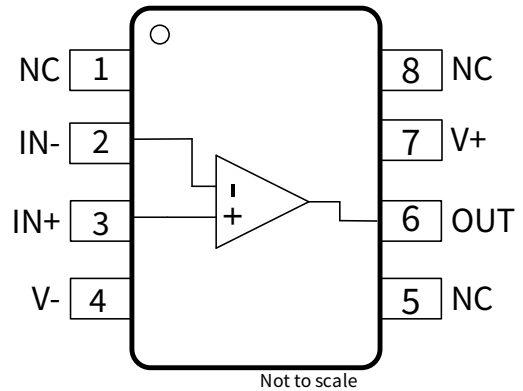

Figure 1-2 NSOPA9011-Q1 8-Pin SOP Package Top View

Table 1-1 NSOPA9011-Q1 Pin Configuration and Description

SYMBOL	5-Pin SOT-23	8-Pin SOP	FUNCTION
	NO.		
IN+	3	3	Noninverting Input
IN-	4	2	Inverting Input
OUT	1	6	Output
V+	5	7	Positive Power supply
V-	2	4	Negative Power supply
NC	-	1	Do not connect
NC	-	5	Do not connect
NC	-	8	Do not connect

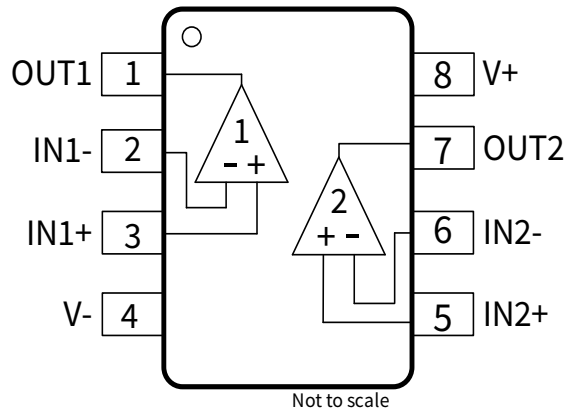

Figure 1-3 NSOPA9012-Q1 8-Pin SOP and MSOP Package Top View

Table 1-2 NSOPA9012-Q1 Pin Configuration and Description

<b>SYMBOL</b>	<b>NO.</b>	<b>FUNCTION</b>
IN1-	2	Channel 1 Inverting Input
IN1+	3	Channel 1 Noninverting Input
OUT1	1	Channel 1 Output
IN2-	6	Channel 2 Inverting Input
IN2+	5	Channel 2 Noninverting Input
OUT2	7	Channel 2 Output
V+	8	Positive Power Supply
V-	4	Negative Power Supply

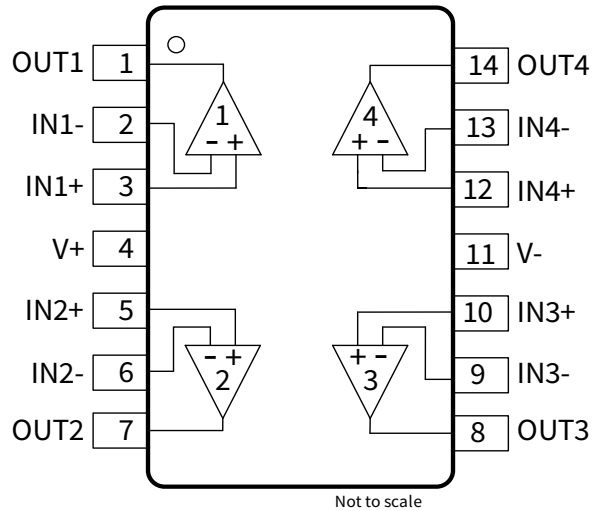

Figure 1-4 NSOPA9014-Q1 14-Pin SOP and TSSOP Package Top View

Table 1-3 NSOPA9014-Q1 Pin Configuration and Description

<b>SYMBOL</b>	<b>NO.</b>	<b>FUNCTION</b>
IN1-	2	Channel 1 Inverting Input
IN1+	3	Channel 1 Noninverting Input
OUT1	1	Channel 1 Output
IN2-	6	Channel 2 Inverting Input
IN2+	5	Channel 2 Noninverting Input
OUT2	7	Channel 2 Output
IN3-	9	Channel 3 Inverting Input
IN3+	10	Channel 3 Noninverting Input
OUT3	8	Channel 3 Output
IN4-	13	Channel 4 Inverting Input
IN4+	12	Channel 4 Noninverting Input
OUT4	14	Channel 4 Output
V+	4	Positive Power Supply
V-	11	Negative Power Supply

## 2. Absolute Maximum Ratings<sup>1</sup>

Parameters	Symbol	Min	Max	Unit
Supply voltage $V_S = (V_+) - (V_-)$	$V_S$	-0.3	42	V
Differential, IN+ to IN- inputs			$(V_S) + 0.2$	V
Common-Mode input voltage		$(V_-) - 0.5$	$(V_+) + 0.5$	V
Output		$(V_-) - 0.5$	$(V_+) + 0.5$	V
Junction temperature	$T_J$		150	°C
Storage temperature	$T_{stg}$	-55	150	°C

## 3. ESD Ratings

Parameters	Ratings	Value	Unit
Electrostatic discharge	Human body model (HBM), per AEC Q100-002	±2000	V
	Charged device model (CDM), per AEC Q100-011	±2000	V

## 4. Recommended Operating Conditions

Parameters	Symbol	Min	Max	Unit
Supply voltage	$V_S$	2.7	40	V
Operating free-air temperature	$T_A$	-40	125	°C

## 5. Thermal Information

Parameters	Symbol	SOT23-5L	SOP-8	MSOP-8	TSSOP-14	SOP-14	Unit
IC Junction-to-Air Thermal Resistance	$\theta_{JA}$	185.7	130.7	176.5	131.4	101.4	°C/W
Junction-to-case (top) thermal resistance	$\theta_{JC}$	108.2	72.8	68.1	51.8	57.6	°C/W
Junction-to-board thermal resistance	$\theta_{JB}$	54.5	74.0	98.2	75.8	57.3	°C/W
Junction-to-top characterization parameter	$\Psi_{JT}$	31.2	24.0	12.0	7.9	18.5	°C/W
Junction-to-board characterization parameter	$\Psi_{JB}$	54.2	73.3	96.7	74.8	56.9	°C/W

<sup>1</sup> Stresses at or above those listed under Absolute Maximum Ratings may cause permanent damage to the product. This is a stress rating only; functional operation of the product at these or any other conditions above those indicated in the operational section of this specification is not implied. Operation beyond the maximum operating conditions for extended periods may affect product reliability

## 6. Electrical Characteristics

$V_S = (V_+) - (V_-) = 40\text{ V}$  ( $\pm 20\text{ V}$ ) at  $T_A = 25^\circ\text{C}$ ,  $R_L = 10\text{ k}\Omega$  connected to  $V_S/2$ ,  $V_{CM} = V_S/2$ , and  $V_{OUT} = V_S/2$ , unless otherwise noted.

Parameters	Symbol	Condition	Min	Typ	Max	Unit
<b>INPUT</b>						
Offset voltage	$V_{OS}$	$V_{CM} = (V_-)$		$\pm 0.3$	$\pm 1.8$	mV
		$T_A = -40^\circ\text{C}$ to $125^\circ\text{C}$			$\pm 2.7$	
Offset voltage drift	$dV_{OS}/dT$	$T_A = -40^\circ\text{C}$ to $125^\circ\text{C}$		$\pm 1.8$		$\mu\text{V}/^\circ\text{C}$
Common-mode input range	$V_{CM}$		$(V_-) - 0.1$		$(V_+) + 0.1$	V
Common mode rejection ratio	CMRR	$V_S = 40\text{V}$ , $(V_-) - 0.1\text{V} < V_{CM} < (V_+) - 2.5\text{V}$ (PMOS pair)	$T_A = 25^\circ\text{C}$	97	118	dB
			$T_A = -40^\circ\text{C}$ to $125^\circ\text{C}$	89		
		$V_S = 4\text{V}$ , $(V_-) - 0.1\text{V} < V_{CM} < (V_+) - 2.5\text{V}$ (PMOS pair)	$T_A = 25^\circ\text{C}$	77	92	
			$T_A = -40^\circ\text{C}$ to $125^\circ\text{C}$	69		
Power supply rejection ratio	PSRR	$V_S = 4\text{V}$ to $40\text{V}$ , $V_{CM} = (V_-)$	$T_A = 25^\circ\text{C}$	123	138	dB
			$T_A = -40^\circ\text{C}$ to $125^\circ\text{C}$	111		
		$V_S = 2.7\text{V}$ to $40\text{V}$ , $V_{CM} = (V_-)$	$T_A = 25^\circ\text{C}$	109	124	
			$T_A = -40^\circ\text{C}$ to $125^\circ\text{C}$	99		
Channel Separation		$f = 0\text{Hz}$		120		dB
Input bias current	$I_B$	$V_S = 2.7\text{V}$ to $40\text{V}$ , $V_{CM} = V_S/2$		$\pm 10$		pA
		$T_A = -40^\circ\text{C}$ to $125^\circ\text{C}^1$		$\pm 10$		nA
Input offset current	$I_{OS}$	$V_S = 2.7\text{V}$ to $40\text{V}$ , $V_{CM} = V_S/2$		$\pm 10$		pA
		$T_A = -40^\circ\text{C}$ to $125^\circ\text{C}$		$\pm 10$		nA
Input Impedance	$Z_{ID}$	Differential		$1.9  5$		$\text{G}\Omega  \text{pF}$
	$Z_{ICM}$	Common-mode		$0.2  4$		$\text{T}\Omega  \text{pF}$
<b>OPEN-LOOP GAIN</b>						
Open-loop voltage gain	$A_{OL}$	$V_S = 40\text{V}$ , $(V_-) + 0.2\text{V} < V_O < (V_+) - 0.2\text{V}$	$T_A = 25^\circ\text{C}$	125	140	dB
			$T_A = -40^\circ\text{C}$ to $125^\circ\text{C}$		132	
		$T_A = 25^\circ\text{C}$	106	121		

		$V_S = 4V, (V_-)$ $+0.2V < V_O < (V_+) - 0.2V$	$T_A = -40^\circ\text{C}$ to $125^\circ\text{C}^1$	112	
		$V_S = 2.7V, (V_-)$ $+0.2V < V_O < (V_+) - 0.2V$	$T_A = 25^\circ\text{C}$	103	117
			$T_A = -40^\circ\text{C}$ to $125^\circ\text{C}$	109	

### Electrical Characteristics (continued)

$V_S = (V_+) - (V_-) = 40\text{ V}$  ( $\pm 20\text{ V}$ ) at  $T_A = 25^\circ\text{C}$ ,  $R_L = 10\text{ k}\Omega$  connected to  $V_S/2$ ,  $V_{CM} = V_S/2$ , and  $V_{OUT} = V_S/2$ , unless otherwise noted.

Parameters	Symbol	Condition	Min	Typ	Max	Unit
<b>OUTPUT</b>						
Output swing from rail headroom		$V_S=2.7\sim 40\text{V}$ , $R_L=\text{no load}$		1	5	mV
		$V_S=2.7\text{V}$ , $R_L=10\text{k}\Omega$		5	10	
		$V_S=40\text{V}$ , $R_L=10\text{k}\Omega$		50	60	
		$V_S=2.7\text{V}$ , $R_L=2\text{k}\Omega$		20	30	
		$V_S=40\text{V}$ , $R_L=2\text{k}\Omega$		250	300	
Short-circuit current	$I_{sc}$	Sinking		55		mA
		Sourcing		65		
Output impedance	$Z_o$	$f = 1\text{ MHz}$ , $I_o = 0\text{ A}$		120		$\Omega$
<b>FREQUENCY RESPONSE</b>						
Gain-bandwidth product	GBP	$V_S = 40\text{ V}$ , $C_L = 10\text{ pF}$		1		MHz
Phase margin	PM	$V_S = 40\text{ V}$ , $C_L = 10\text{ pF}$		73		Degree
Settling time	$T_s$	To 0.1%, 10 V Step, $C_L = 10\text{ pF}$		7.2		$\mu\text{s}$
		To 0.1%, 2 V Step, $C_L = 10\text{ pF}$		2.5		
		To 0.01%, 10 V Step, $C_L = 10\text{ pF}$		7.4		
		To 0.01%, 2 V Step, $C_L = 10\text{ pF}$		3.2		
Slew rate	SR	10-V step, $G = +1$		2		$\text{V}/\mu\text{s}$
Total harmonic distortion + noise	THD+N	$V_{rms} = 1\text{ V}$ , $G = 1$ , $f = 1\text{ kHz}$ , $R_L = 10\text{k}\Omega$		92		dB
Overload recovery time		$V_{IN} \times \text{Gain} > V_S$		1000		ns
EMI rejection ratio	EMIRR	$f = 1\text{ GHz}$		80		dB
<b>NOISE (INPUT REFERRED)</b>						
Input voltage noise density	$e_n$	$f = 1\text{ kHz}$		28		$\text{nV}/\sqrt{\text{Hz}}$
		$f = 10\text{ kHz}$		22		
Input voltage noise	$e_{n,p-p}$	$f = 0.1\text{ Hz to }10\text{ Hz}$		14		$\mu\text{Vpp}$
<b>POWER SUPPLY</b>						
Operating voltage range	$V_S$		2.7		40	V
Quiescent current per channel, $V_{CM}=V_-$	$I_Q$	$V_S=2.7\text{V}$ , $I_o = 0\text{A}$		120	180	$\mu\text{A}$
			$T_A = -40^\circ\text{C to }125^\circ\text{C}^1$		210	
		$V_S=2.7\text{V}$ , $I_o = 0\text{A}$ NSOPA9011		140	200	
			$T_A = -40^\circ\text{C to }125^\circ\text{C}^1$		235	
		$V_S=40\text{V}$ , $I_o = 0\text{A}$		145	200	
			$T_A = -40^\circ\text{C to }125^\circ\text{C}^1$		230	
		$V_S=40\text{V}$ , $I_o = 0\text{A}$ NSOPA9011		170	240	
			$T_A = -40^\circ\text{C to }125^\circ\text{C}^1$		260	

<sup>1</sup> Data under  $T_A = -40^\circ\text{C to }125^\circ\text{C}$  condition is guaranteed by Characterization only.

### 7. Typical Performance Characteristics

For  $V_S = (V_+) - (V_-) = 40\text{ V} (\pm 20\text{ V})$  at  $T_A = 25^\circ\text{C}$ ,  $R_L = 10\text{ k}\Omega$  connected to  $V_S/2$ ,  $V_{CM} = V_S/2$ , and  $V_{OUT} = V_S/2$ , unless otherwise noted.

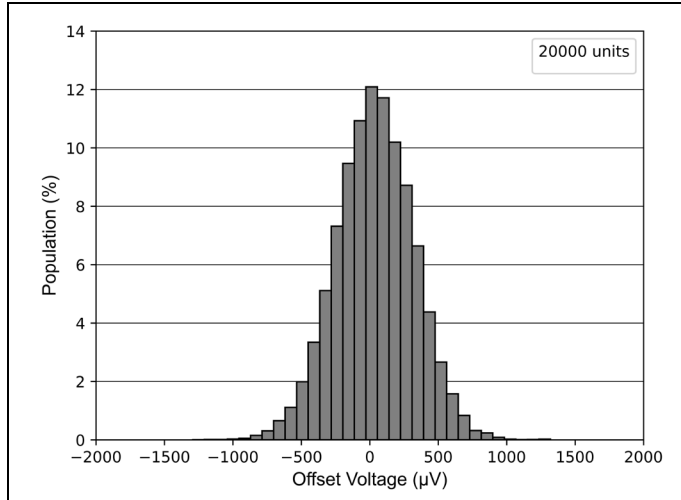

Figure 7-1 Offset Voltage Production Distribution ( $V_{CM} = V_-$ )

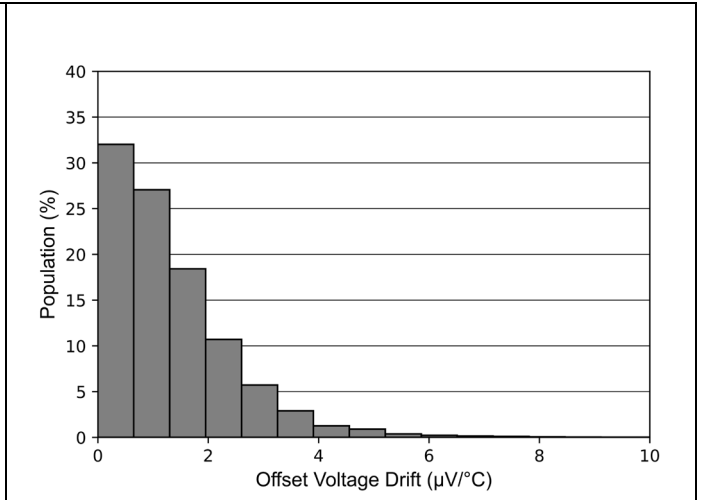

Figure 7-2 Offset Voltage Drift Distribution ( $V_{CM} = V_-$ )

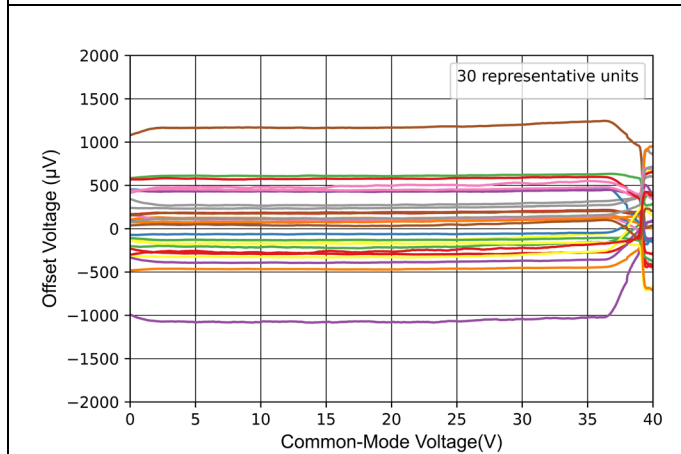

Figure 7-3 Offset Voltage vs Common-Mode Voltage

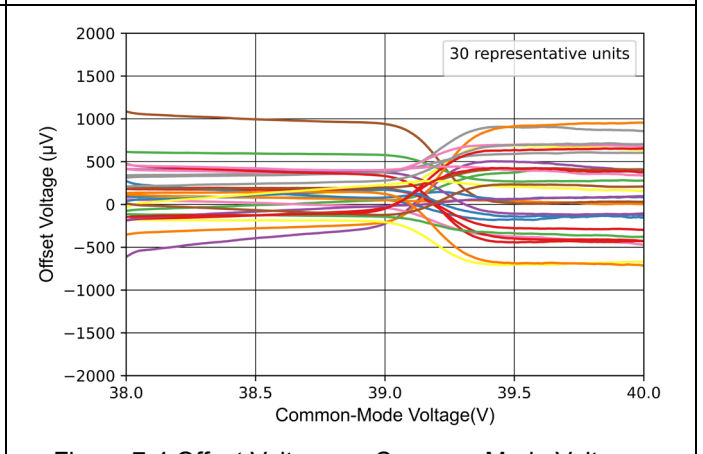

Figure 7-4 Offset Voltage vs Common-Mode Voltage, Transition

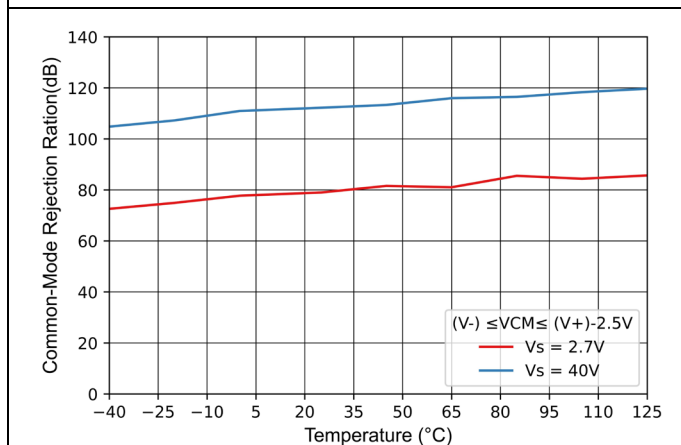

Figure 7-5 CMRR vs Temperature

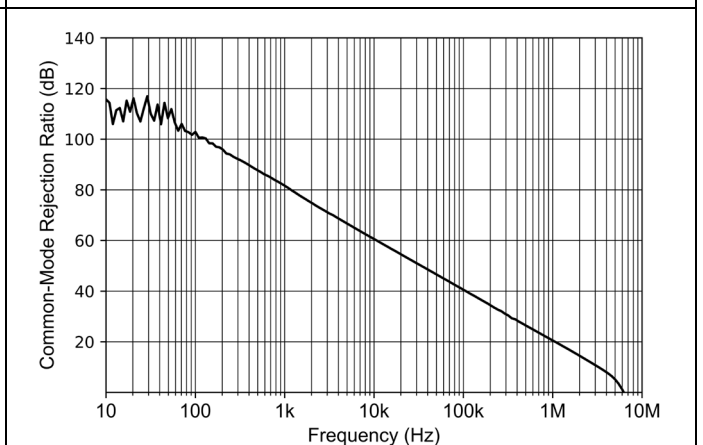

Figure 7-6 Common-Mode Rejection Ratio vs Frequency

Typical Performance Characteristics (continued)

For  $V_S = (V_+) - (V_-) = 40\text{ V} (\pm 20\text{ V})$  at  $T_A = 25^\circ\text{C}$ ,  $R_L = 10\text{ k}\Omega$  connected to  $V_S/2$ ,  $V_{CM} = V_S/2$ , and  $V_{OUT} = V_S/2$ , unless otherwise noted.

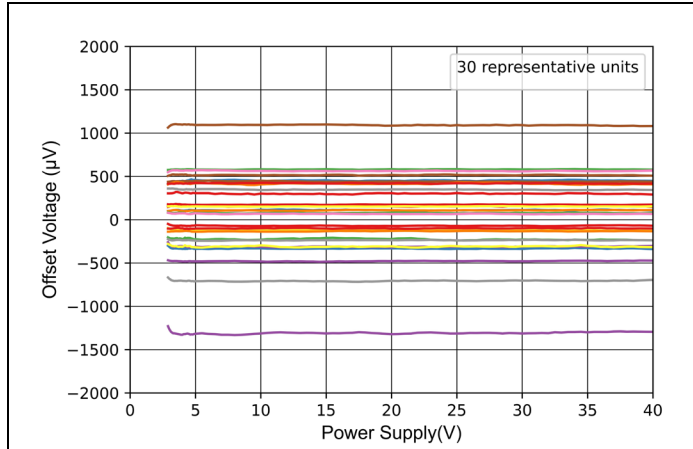

Figure 7-7 Offset Voltage vs Power Supply ( $V_{CM} = V_-$ )

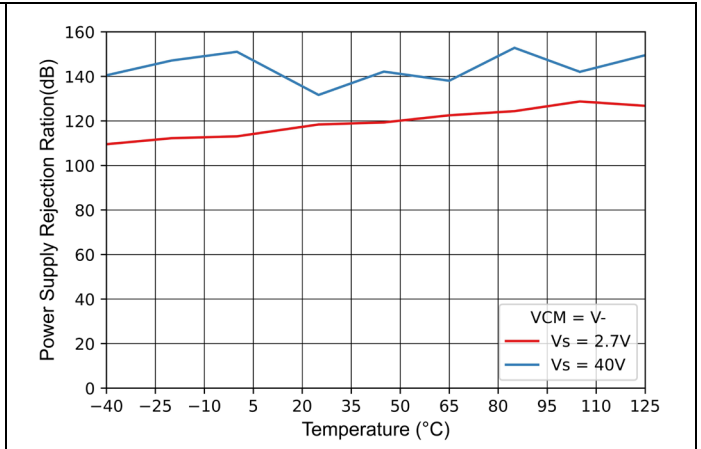

Figure 7-8 PSRR vs Temperature

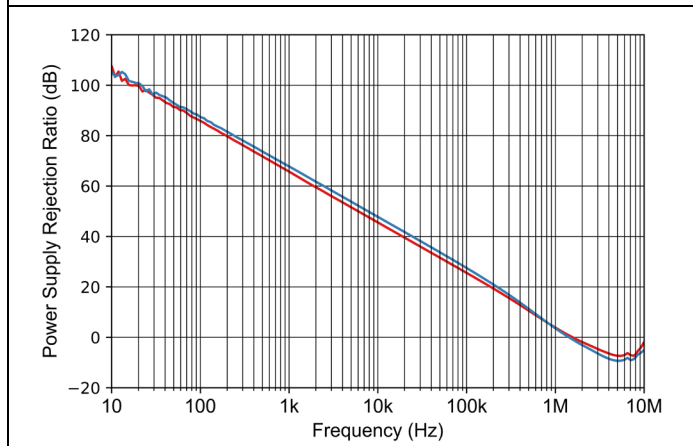

Figure 7-9 Power-Supply Rejection Ratio vs Frequency

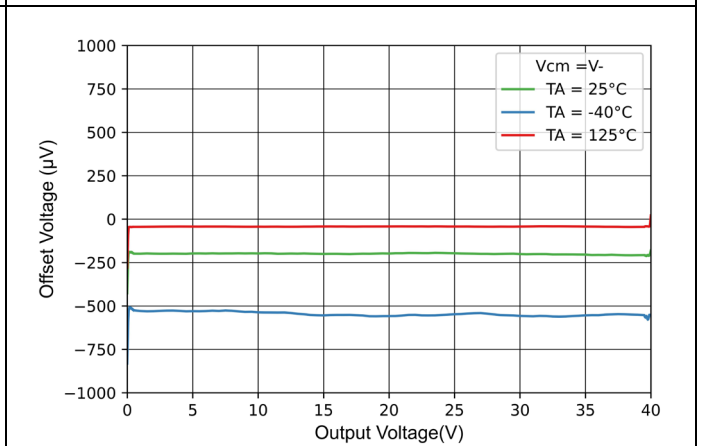

Figure 7-10 Offset Voltage vs Output Voltage

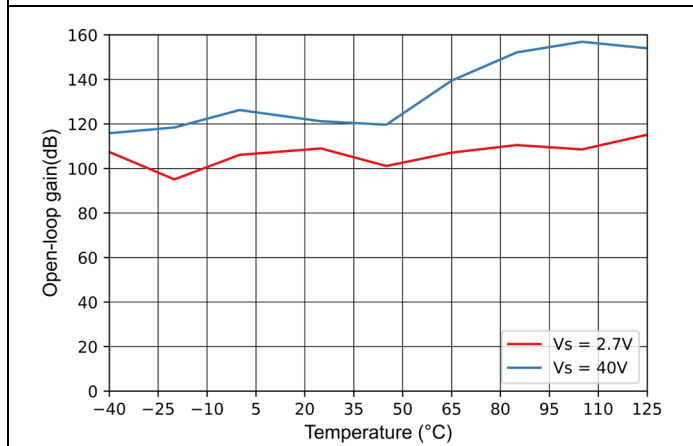

Figure 7-11 Open-Loop Voltage Gain vs Temperature

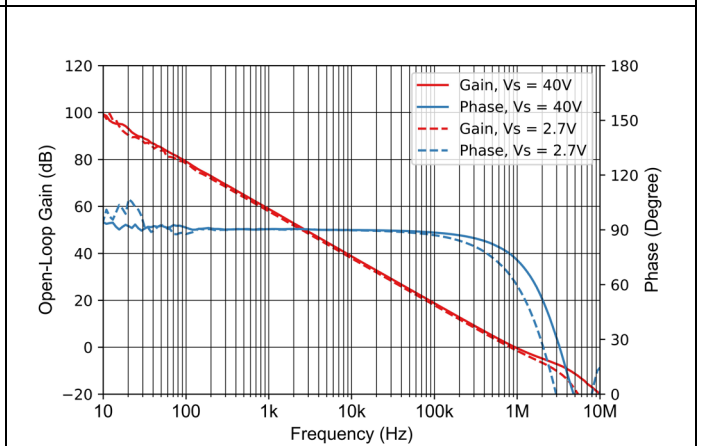

Figure 7-12 Open Loop Gain vs Frequency

Typical Performance Characteristics (continued)

For  $V_S = (V_+) - (V_-) = 40\text{ V}$  ( $\pm 20\text{ V}$ ) at  $T_A = 25^\circ\text{C}$ ,  $R_L = 10\text{ k}\Omega$  connected to  $V_S/2$ ,  $V_{CM} = V_S/2$ , and  $V_{OUT} = V_S/2$ , unless otherwise noted.

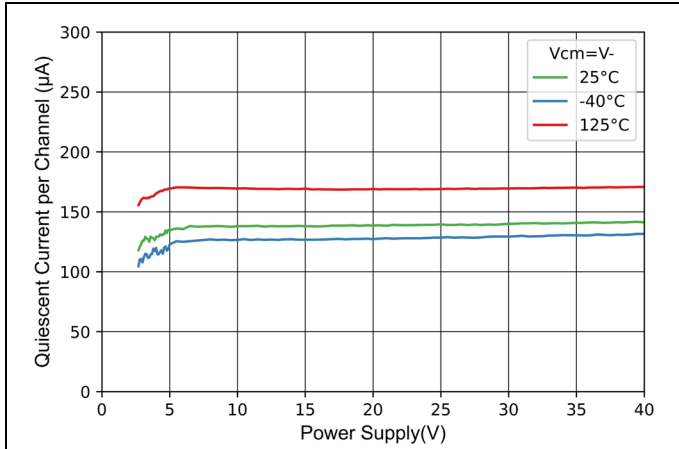

Figure 7-13 Quiescent Current vs Supply Voltage

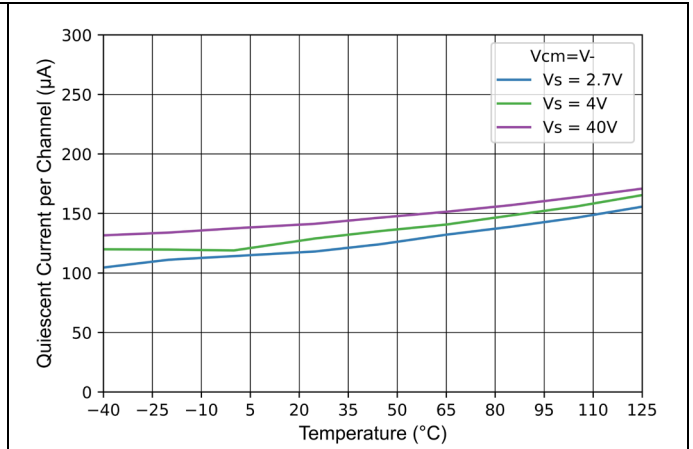

Figure 7-14 Quiescent Current vs Temperature

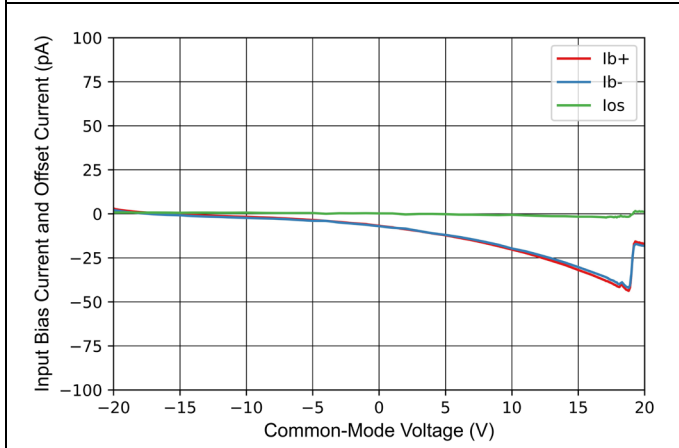

Figure 7-15 Input Bias Current vs Common-Mode Voltage

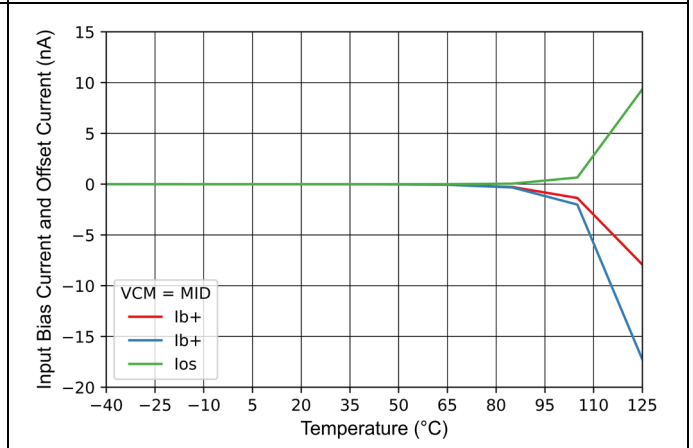

Figure 7-16 Input Bias Current vs Temperature

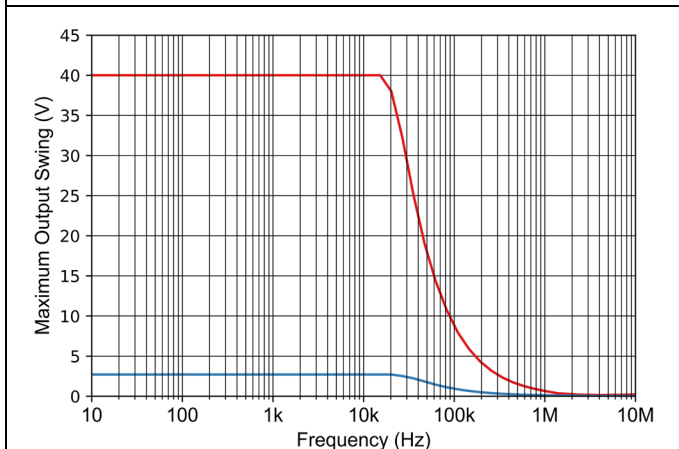

Figure 7-17 Maximum Peak Output Voltage vs. Frequency

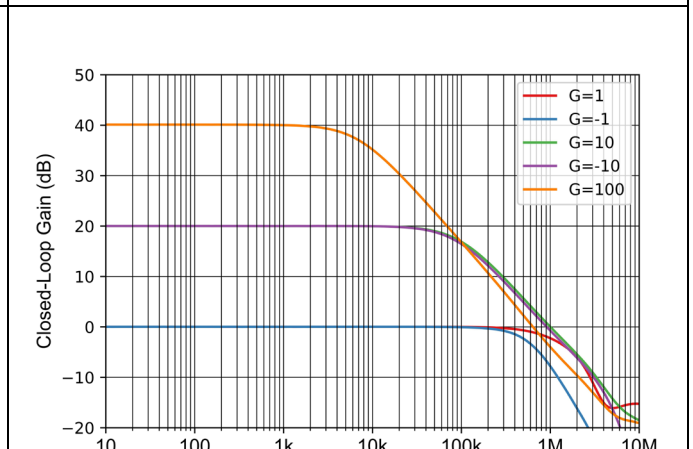

Figure 7-18 Closed Loop Gain and Phase vs Frequency

Typical Performance Characteristics (continued)

For  $V_s = (V_+) - (V_-) = 40\text{ V}$  ( $\pm 20\text{ V}$ ) at  $T_A = 25^\circ\text{C}$ ,  $R_L = 10\text{ k}\Omega$  connected to  $V_s/2$ ,  $V_{CM} = V_s/2$ , and  $V_{OUT} = V_s/2$ , unless otherwise noted.

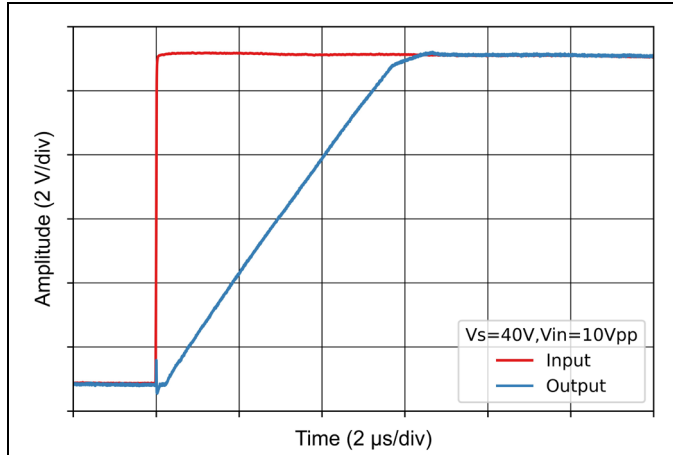

Figure 7-19 Large-Signal Step Response (Rising)

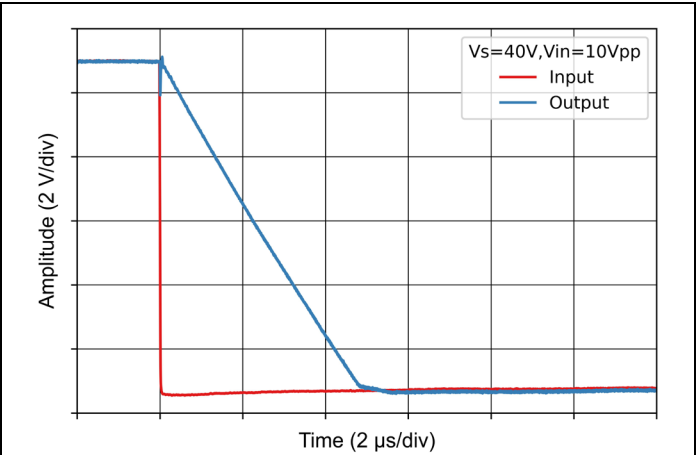

Figure 7-20 Large-Signal Step Response (Falling)

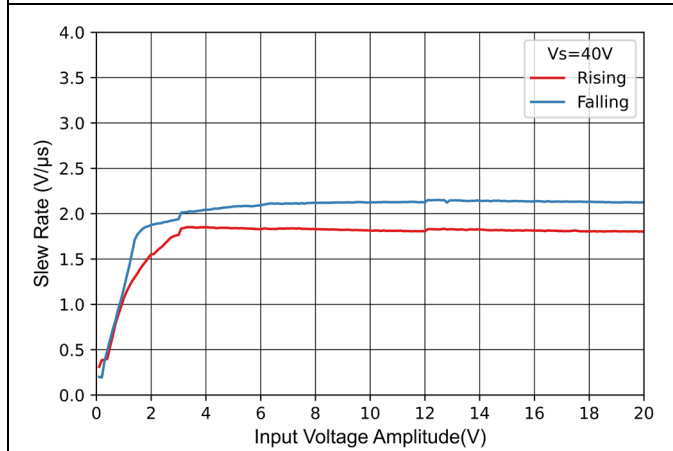

Figure 7-21 Slew Rate vs Input Voltage Amplitude

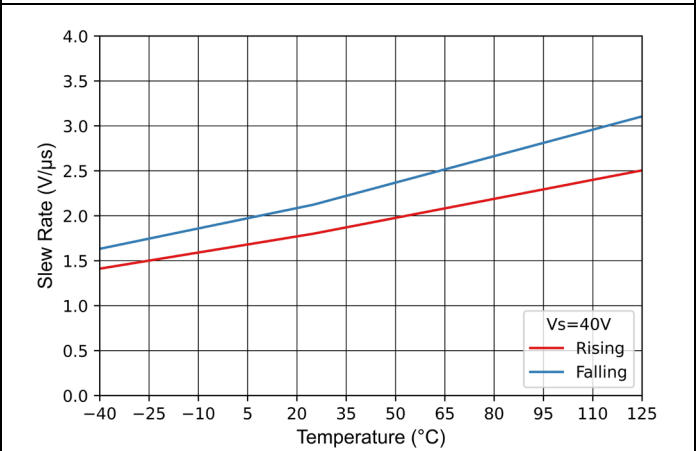

Figure 7-22 Slew Rate vs Temperature

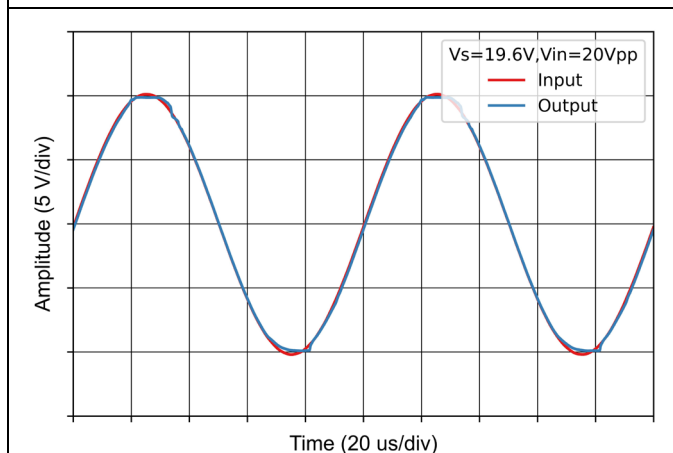

Figure 7-23 No Phase Reversal

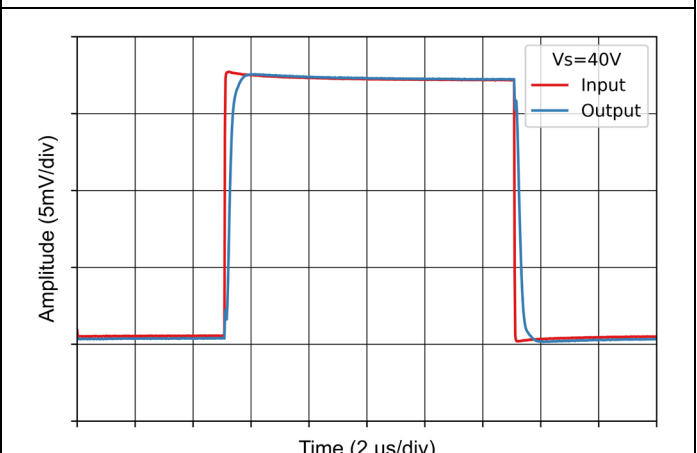

Figure 7-24 Small-Signal Step Response

Typical Performance Characteristics (continued)

For  $V_s = (V_+) - (V_-) = 40\text{ V}$  ( $\pm 20\text{ V}$ ) at  $T_A = 25^\circ\text{C}$ ,  $R_L = 10\text{ k}\Omega$  connected to  $V_s/2$ ,  $V_{CM} = V_s/2$ , and  $V_{OUT} = V_s/2$ , unless otherwise noted.

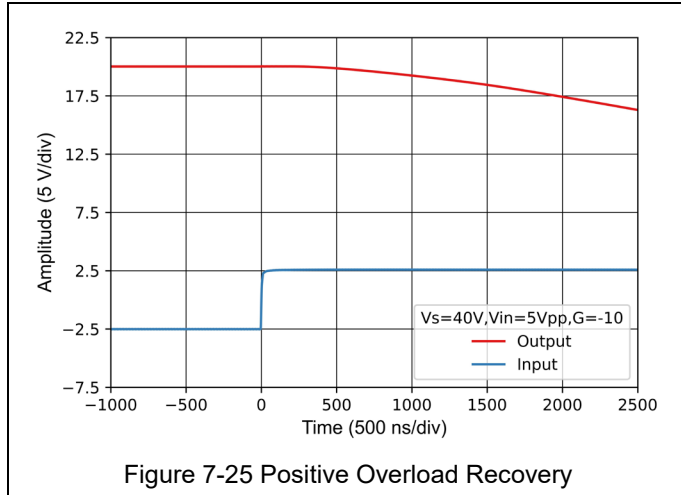

Figure 7-25 Positive Overload Recovery

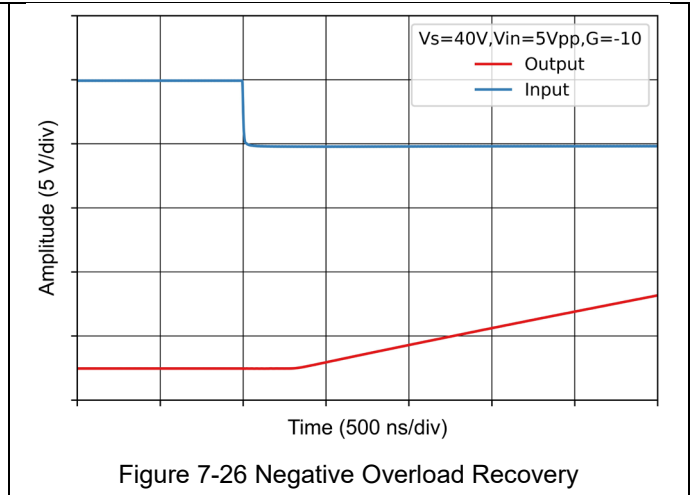

Figure 7-26 Negative Overload Recovery

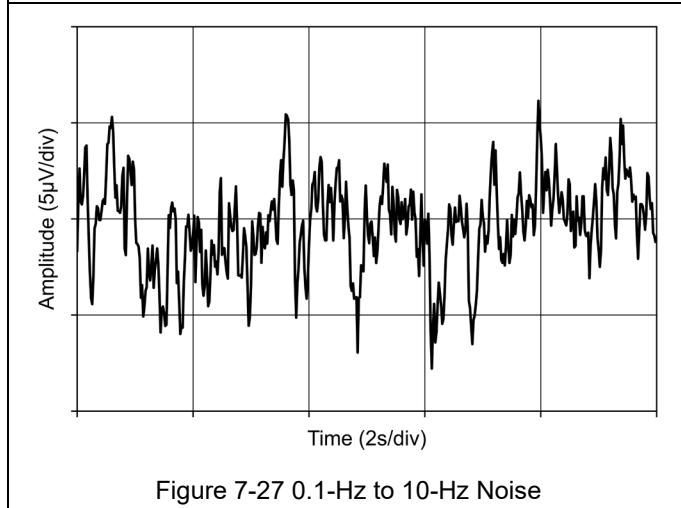

Figure 7-27 0.1-Hz to 10-Hz Noise

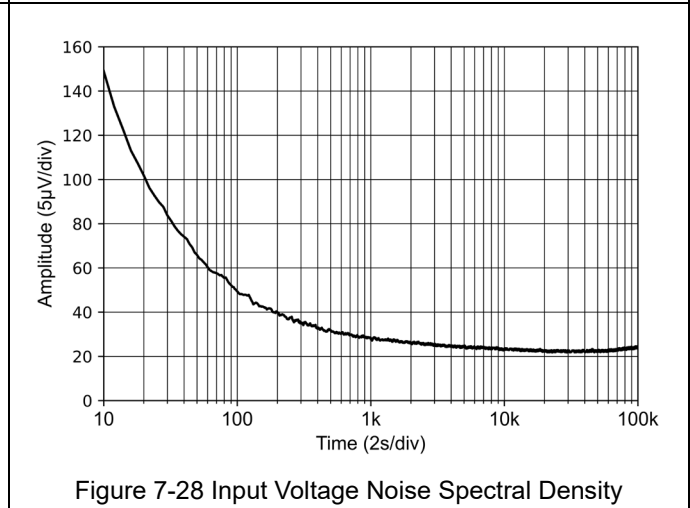

Figure 7-28 Input Voltage Noise Spectral Density

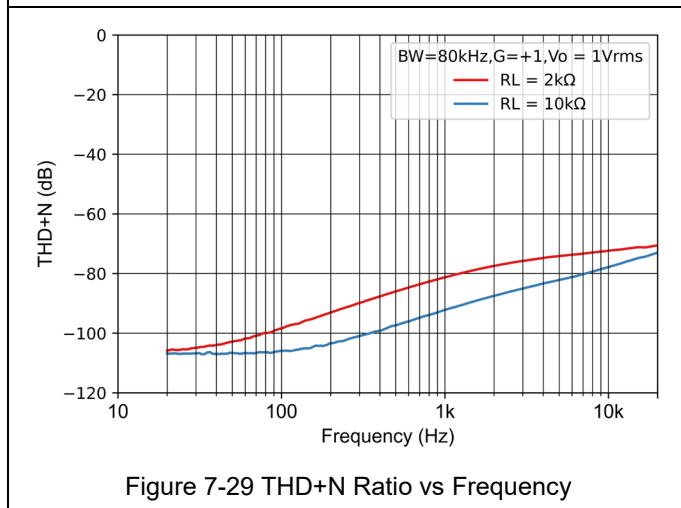

Figure 7-29 THD+N Ratio vs Frequency

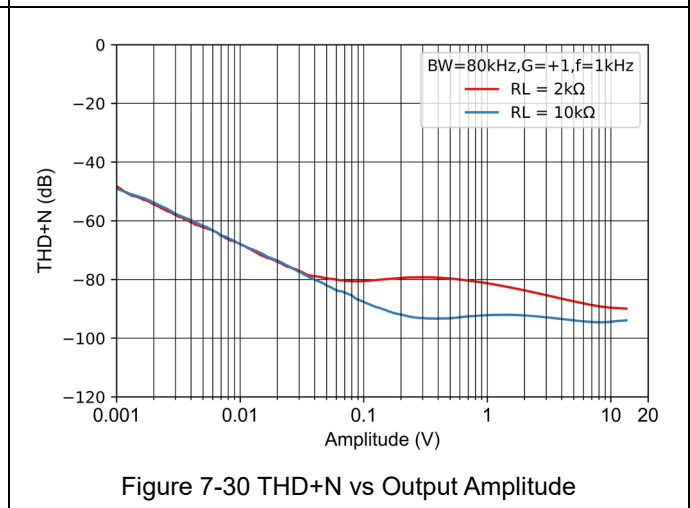

Figure 7-30 THD+N vs Output Amplitude

**Typical Performance Characteristics (continued)**

For  $V_S = (V_+) - (V_-) = 40\text{ V}$  ( $\pm 20\text{ V}$ ) at  $T_A = 25^\circ\text{C}$ ,  $R_L = 10\text{ k}\Omega$  connected to  $V_S/2$ ,  $V_{CM} = V_S/2$ , and  $V_{OUT} = V_S/2$ , unless otherwise noted.

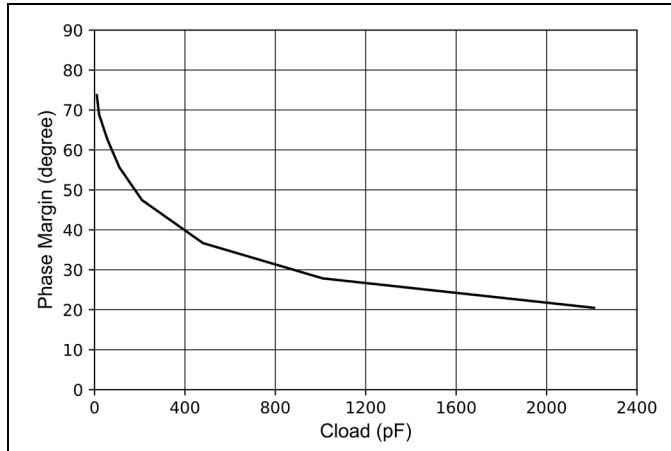

Figure 7-31 Phase Margin vs Capacitive Load

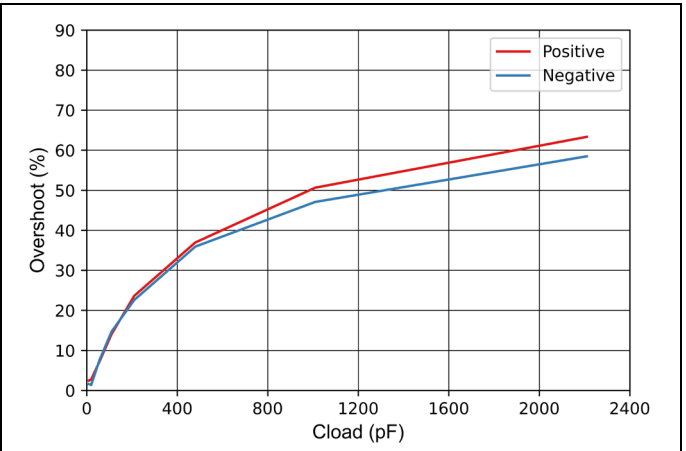

Figure 7-32 Small-Signal Overshoot vs Capacitive Load

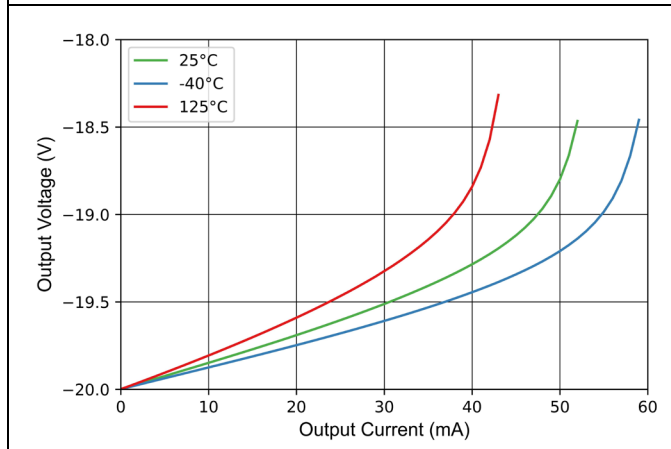

Figure 7-33 Output Voltage Swing vs Output Sinking Current

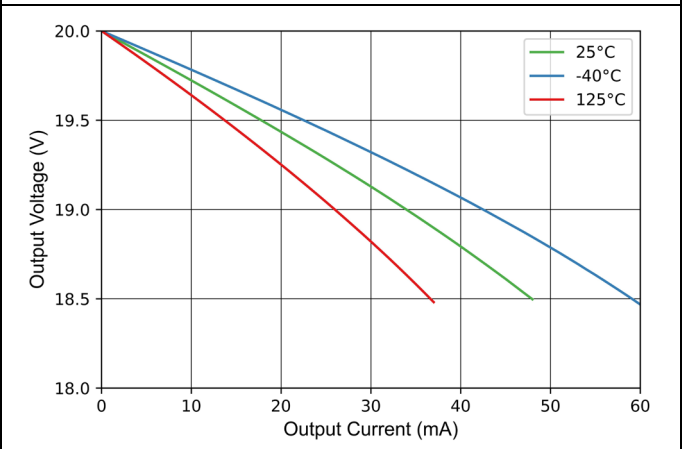

Figure 7-34 Output Voltage Swing vs Output Sourcing Current

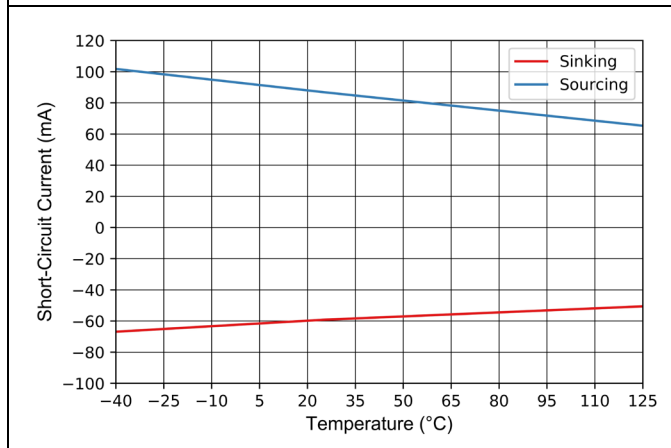

Figure 7-35 Short-Circuit vs Temperature

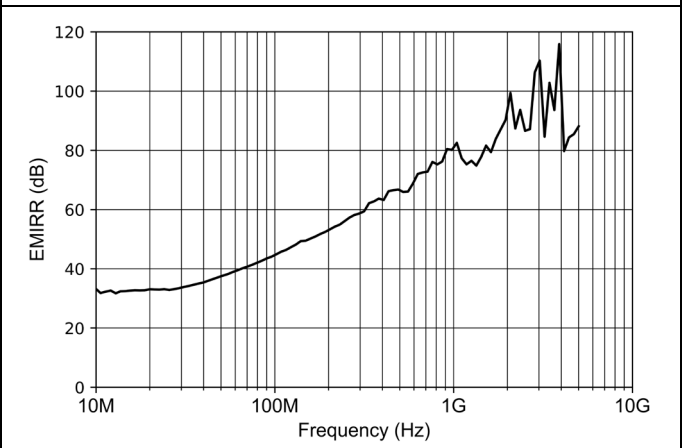

Figure 7-36 EMIRR vs Frequency

**Typical Performance Characteristics (continued)**

For  $V_S = (V_+) - (V_-) = 40\text{ V}$  ( $\pm 20\text{ V}$ ) at  $T_A = 25^\circ\text{C}$ ,  $R_L = 10\text{ k}\Omega$  connected to  $V_S/2$ ,  $V_{CM} = V_S/2$ , and  $V_{OUT} = V_S/2$ , unless otherwise noted.

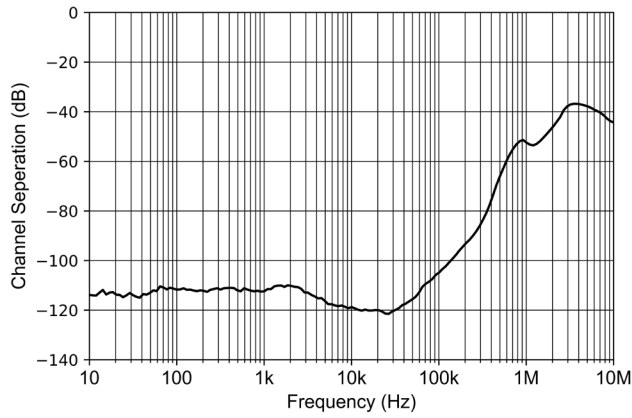

Figure 7-37 Channel Separation vs Frequency

## 8. Function Description

### 8.1. Overview

The NSOPA901x-Q1 series are high-voltage general-purpose amplifiers that can operate up to 40V. These devices offer excellent parameters and are particularly suitable for high slew rate and cost-sensitive applications that will require high voltage signals, such as motor drives and inverter systems.

### 8.2. Functional Block Diagram

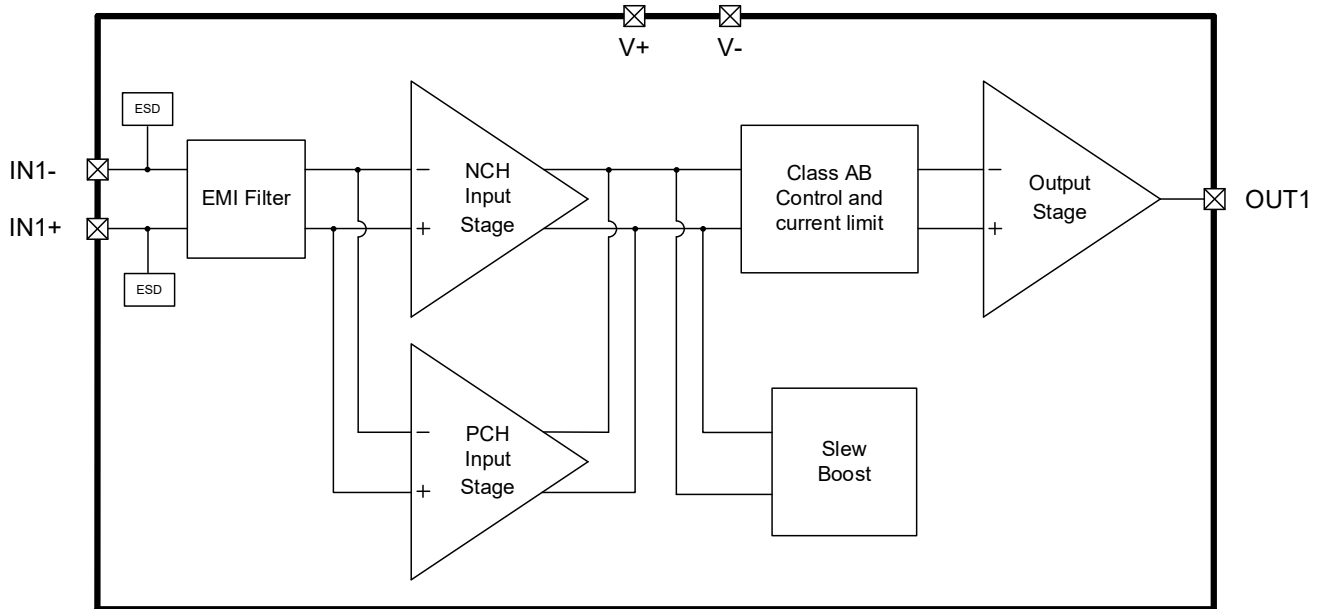

Figure 8-1 NSOPA901x-Q1 Functional block Diagram (One channel is shown)

### 8.3. Feature Description

#### 8.3.1. Pulse Friendly

Traditional op amps use back-to-back diode input stages to limit the differential input range. If the device operates in open-loop conditions, once the voltage between the two input pins exceeds the limit voltage, unexpected current will flow into the device and may cause device damage.

Using new input stage topology, NSOPA901x-Q1 provides full 40V differential input range. when it works in open-loop case, it will not sink any current from source and behave as the comparator.

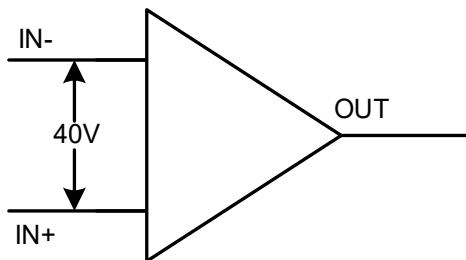

Figure 8-2 NSOPA901x-Q1 input stage

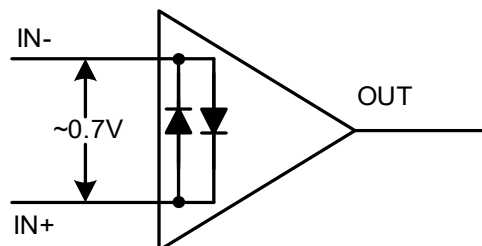

Figure 8-3 Traditional op-amp input stage

### 8.3.2.Slew Rate Boost

Because of slew rate boost feature, document state that NSOPA901x-Q1 has a about 12V/μs slew rate. Actually, the slew rate of device depends on the input amplitude voltage. The figure illustrates the behavior of this feature.

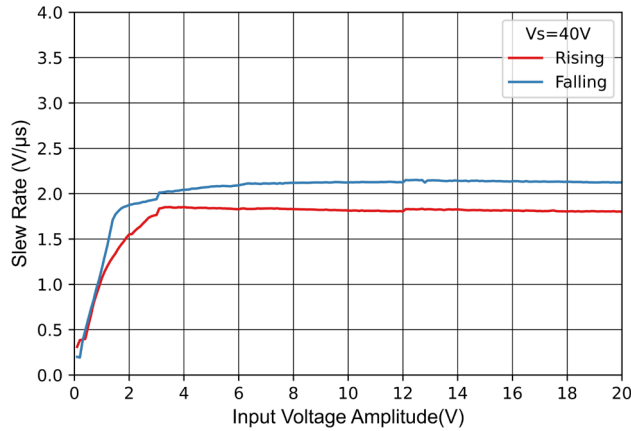

Figure 8-4 Slew-Rate vs Input Voltage Amplitude

### 8.3.3.Common-Mode Input Stage

The NSOPA901x-Q1 is a 40V true rail-to-rail input op amp with an input common-mode range of 100mV beyond either supply rail. This wide range is achieved by paralleling complementary N-channel and P-channel differential input pairs, as shown in Figure 8-5. N-channel pairs are active when the input voltage is close to the positive supply rail, typically – 1 V to 100 mV above the positive supply (V+). The P-channel pair is active over an input range from 100 mV below the negative supply to approximately (V+) – 2.5 V. There is a small transition region, typically (V+) – 2.5 V to (V+) – 1 V, where both input pairs are on. This transition region will vary slightly with process variations, and within this region, PSRR, CMRR, offset voltage, offset drift, noise, and THD performance may be degraded compared to operation outside this region.

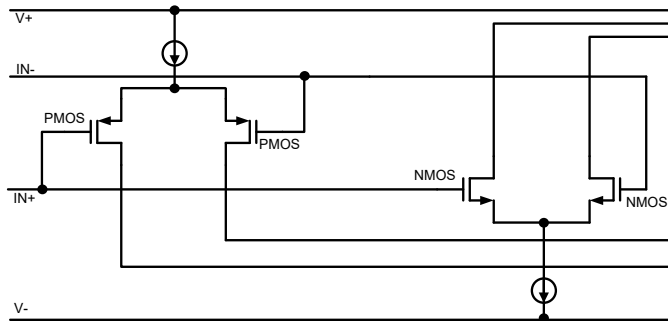

Figure 8-5 NSOPA901x-Q1 Rail-to-rail Input Stage

**8.3.4.EMI Rejection**

The NSOPA901x-Q1 uses integrated electromagnetic interference (EMI) filtering to reduce the impact of EMI from sources such as wireless communications and densely populated circuit boards that mix analog signal chains and digital components. The advantage of NSOPA901x-Q1 is that EMI immunity can be improved through circuit design technology. Figure 8-6 shows the test results on NSOPA901x-Q1.

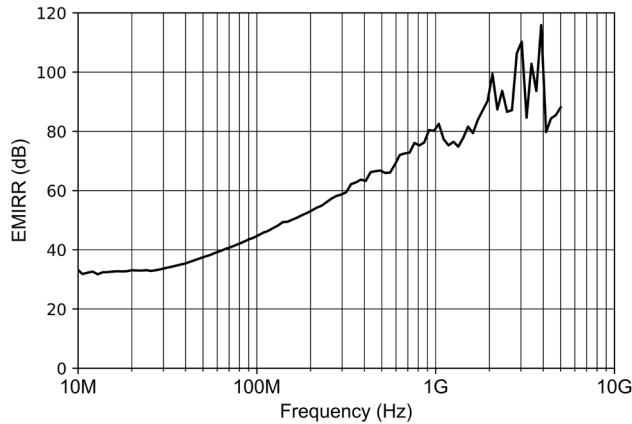

Figure 8-6 NSOPA901x-Q1 EMIRR vs Frequency

**8.3.5.Drive Capacitive Load**

The NSOPA901x-Q1 has a resistive output stage capable of driving moderate capacitive loads, and by utilizing isolation resistors, the device can be easily configured to drive large capacitive loads. The specific op amp circuit configuration, layout, gain, and output loading are important factors in determining whether the amplifier will operate stably. Some factors to consider.

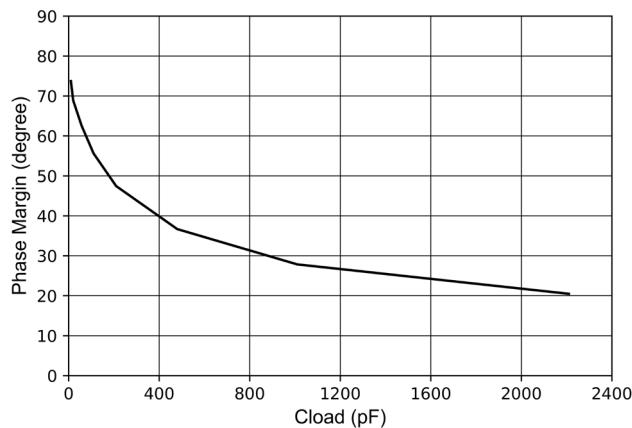

Figure 8-7 NSOPA901x-Q1 Phase Margin vs Capacitive Load

To obtain additional drive capability in a unity-gain configuration, capacitive load drive can be improved by inserting a small resistor,  $R_{iso}$ , in series with the output, as shown in Figure 8-8. This resistor significantly reduces ringing and maintains DC performance under purely capacitive loads. However, if a resistive load is placed in parallel with a capacitive load, a voltage divider is created, which introduces a gain error at the output and slightly reduces the output swing. The error introduced is proportional to the ratio  $R_{iso}/R_L$  and is usually negligible at low voltage output levels.

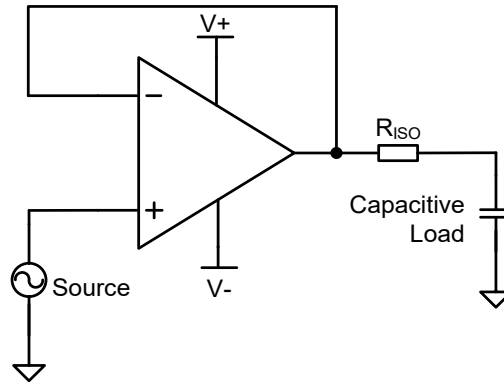

Figure 8-8 Insert isolation Resistor to drive large Capacitive Load

**8.3.6. Thermal Protection**

The internal power dissipation of any amplifier causes its internal (junction) temperature to rise. This phenomenon is called self-heating. The absolute maximum junction temperature of the NSOPA901x-Q1 is 150°C.

Exceeding this temperature may damage the device. The NSOPA901x-Q1 features thermal protection to reduce damage caused by self-heating. This protection is achieved by monitoring the device temperature and turning off the op amp output drive when the temperature is above 170°C. Figure 8-9 shows an application example of NSOPA901x-Q1 that has significant self-heating due to power dissipation (0.5 W). Thermal calculations show that for an ambient temperature of 105°C, the device junction temperature must reach 177°C. However, real devices shut down the output drive to return to a safe junction temperature. Figure 8-9 shows how the circuit behaves during thermal protection. During normal operation, the device acts as a buffer so the output is 10V. When self-heating causes the device junction temperature to rise above internal limits, thermal protection forces the output into a high-impedance state and pulls the output to ground through resistor RL.

If the condition causing excessive power dissipation is not removed, the amplifier will remain in an off and enabled state until the output fault is corrected.

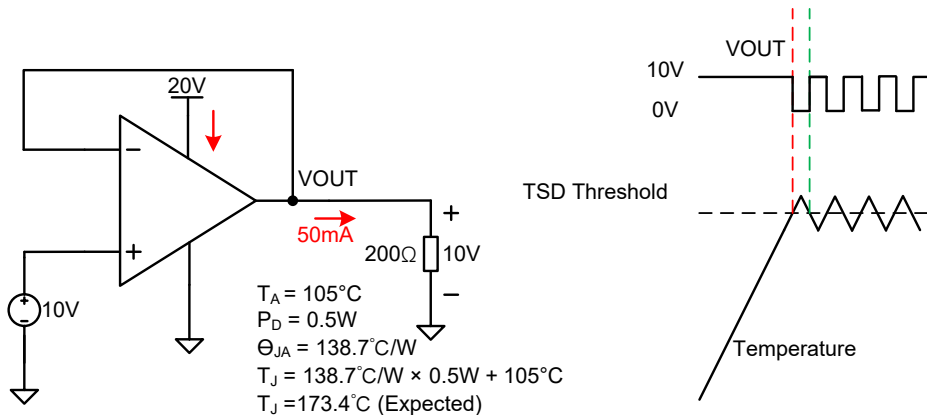

Figure 8-9 Thermal shut down and recovery

**8.3.7. Electrical Overstress**

Always, internal electrostatic discharge (ESD) protection is built into these circuits to protect them from accidental ESD events both before and during product assembly.

Having a good understanding of this basic ESD circuitry and its relevance to an electrical overstress event is helpful. Figure 8-10 shows an illustration of the ESD circuits contained in the NSOPA901x-Q1 (indicated by the dotted area area). The ESD protection circuitry involves several current-steering diodes connected from the input and output pins and routed back to the internal power-supply lines, where the diodes meet at an absorption device or the power-supply ESD cell, internal to the operational amplifier. This protection circuitry is intended to remain inactive during normal circuit operation.

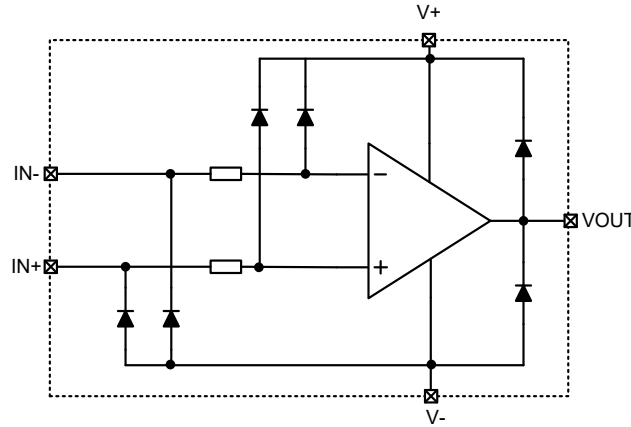

Figure 8-10 Internal ESD Equipment Model

Designers often ask questions about the capability of an operational amplifier to withstand electrical overstress (EOS). These questions tend to focus on the device inputs but may involve the supply voltage pins or even the output pin. Each of these different pin functions have electrical stress limits determined by the voltage breakdown characteristics of the particular semiconductor fabrication process and specific circuits connected to the pin.

Electrostatic Discharge (ESD) is defined the transfer of electrostatic charge between bodies or surfaces at different electrostatic potential. ESD is regarded as a high voltage(kV), short duration event(1-100ns). Besides, it is fast edges and lower power event.

But unlike ESD problems, EOS is another common device problem. Electrical Over Stress (EOS) is defined the exposure of an item to current or voltage beyond its maximum ratings.

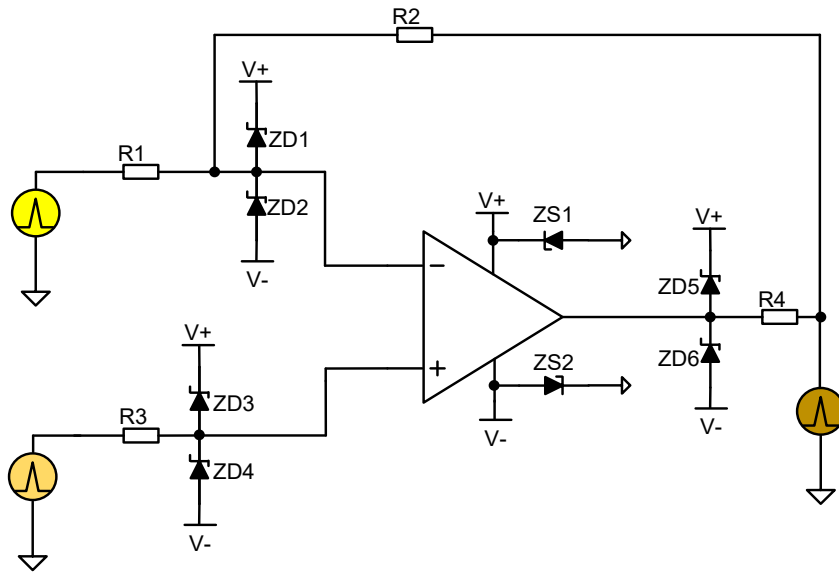

Figure 8-11 External component to enhance EOS performance

Figure 8-11 shows how to use external components to enhance the circuitry robustness.

1. SDx are small signal Schottky diodes. Using power Schottky for power operational amplifier. Diodes limits EOS Voltage to  $[(V+) + 0.3V]$  or  $[(V-) - 0.3V]$ .
2. ZS1 and ZS2 are Zener diodes or unipolar semiconductor Transient Voltage Suppressors (TVS). They prevent device supply over-voltage, provide reverse polarity protection, and provide a current path for  $I_q$  if one supply floats.
3. R1, R2 limit current through SD1, SD2.
4. R3 limits current through SD3, SD4.
5. R4 limits current through SD5, SD6. R4 is inside the feedback loop adding little error at output voltage.
6. **Check Absolute Maximum Ratings before using NSOPA901x-Q1 and never violate the Absolute Maximum Ratings.**

## 9. Application

### 9.1. Active Filter

NSOPA901x-Q1 can be configured into different types of filters for processing complex signals. Here is a brief explanation of Sallen-key filter type.

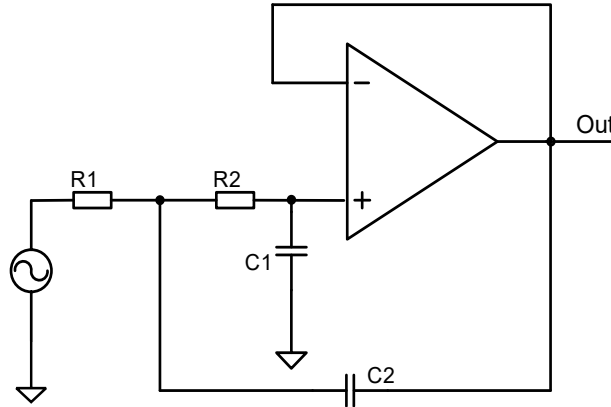

Figure 9-1 Second-Order Sallen-Key Filter

The transfer function of this circuit can be derived as:

$$f_c = \frac{1}{2\pi\sqrt{R_1 R_2 C_1 C_2}}$$

1

The 1kHz low pass filter is taken as a design example. By setting R1=9.1kΩ, R2=13 kΩ, C1=10nF and C2=20.5nF, we can get the amplitude-frequency and phase-frequency curves as follows.

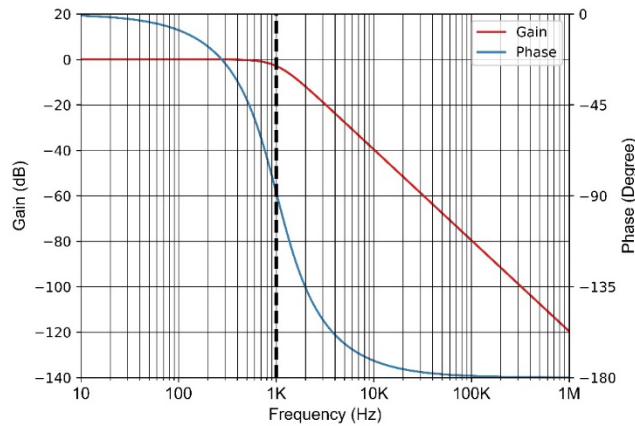

Figure 9-2 Amplitude-Frequency and Phase-Frequency Curves

## 9.2. High-Side Current Sensing

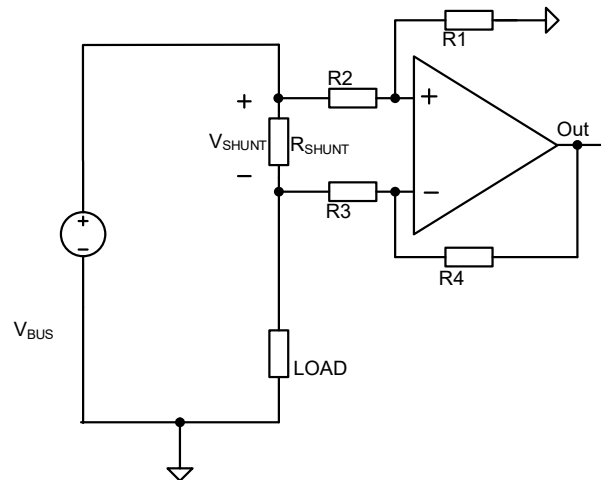

Figure 9-3 High-Side Current Sensing

NSOPA901x-Q1 can be used in the high-side current sensing application.

When designing high-side current sensing circuits, the common-mode voltage of the op amp must be considered. The common-mode voltage is set by the bus voltage and the resistor divider formed by resistors R1 and R2 (shown in Figure 1) and is calculated using Equation 1 below.

$$V_{cm} = \frac{R1}{R1 + R2} \times V_{BUS} \quad 1$$

Typically,  $R1=R4$ ,  $R2=R3$ . To ensure accuracy, it is important that R1 and R4 and R2 to R3 match closely. Any mismatch may result in gain and CMRR errors. It is recommended to minimize these errors by using matched resistors with an accuracy of 0.1% for external circuitry.

In low-power application, the consumption of resistor shall be taken into consideration.

$$GAIN = \frac{R4}{R3} \quad 2$$

The input offset voltage must also be considered when determining the accuracy of the solution. Input offset voltage is inherent to the op amp and changes the expected output voltage, as shown in Equation 3.

This error can be significant if the offset voltage is close to the same value as the voltage across the shunt resistor ( $V_{SHUNT}$ ). It is recommended to use op amps with lower inherent offset voltages to minimize system errors.

$$V_{OUT} = GAIN \times V_{SHUNT} + (GAIN + 1) \times V_{OS} \quad 3$$

## 10. Layout Guidance

### 10.1. Guidelines

Poor op amp PCB layout will deteriorate the chip parameters, or even worse, cause it to work abnormally. For better performance, some tips should be considered.

- Noise can propagate into the analog circuitry through the board's power connections and to the power pins of the op amp itself. Bypass capacitors are used to reduce coupled noise by providing a low impedance path to ground.
- Connect a low ESR 0.1 $\mu$ F ceramic bypass capacitor between each supply pin and ground as close to the device as possible. A single bypass capacitor from V+ to ground is sufficient for single-supply applications.
- To reduce parasitic coupling, keep input traces as far away from power supply or output traces as possible. If these traces cannot be kept separate, route them at a 90-degree angle

It's much better to run overly sensitive traces than to run traces parallel to noisy traces.

- External components should be located as close to the device as possible, as shown in following figure. Keeping RF and RG close to the inverting input minimizes parasitic capacitance.
- Keep input traces as short as possible. Remember, the input traces are the most sensitive parts of the circuit.
- For best performance, cleaning is recommended after PCB board assembly.

### 10.2. Example

A single channel is shown as follow. The rest channels should be handled with identical way but not shown in the figure.

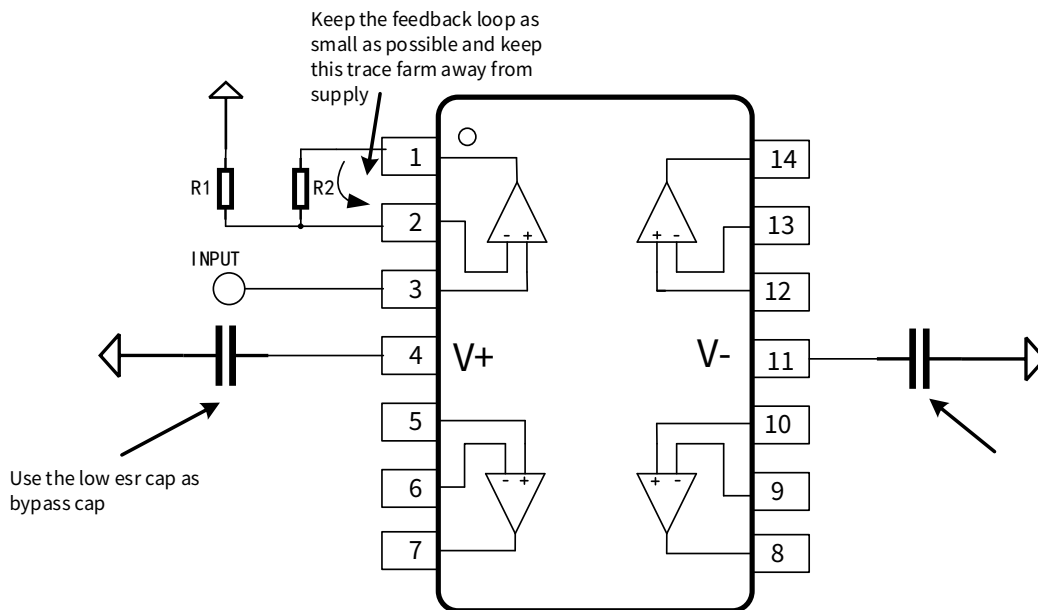
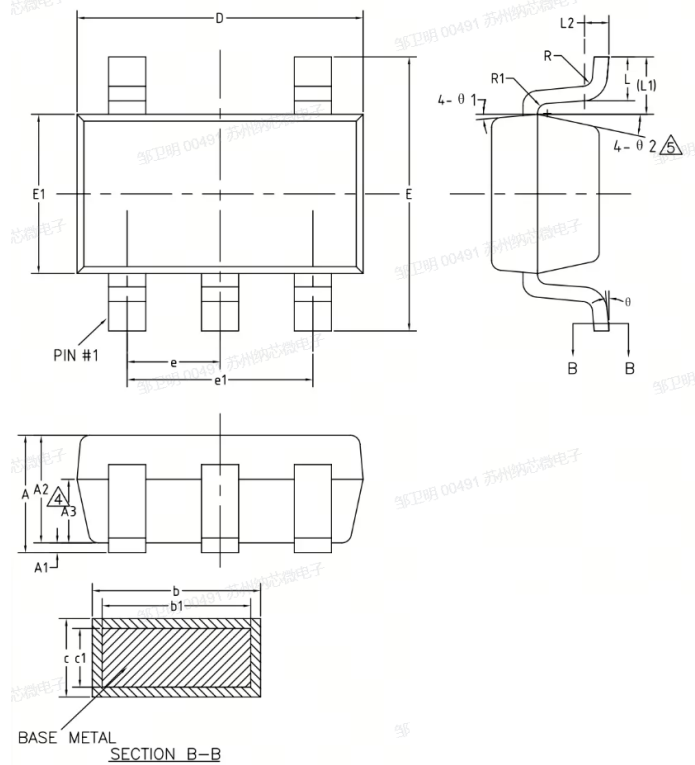

Figure 10-1 Layout example

### 11. Package Information

#### 11.1. SOT23-5L



Symbol	Dimensions In Millimeters		Dimensions In Inches	
	Min	Max	Min	Max
A	---	1.25	---	0.049
A1	---	0.15	---	0.006
A2	1.00	1.20	0.039	0.047
A3	0.60	0.70	0.024	0.028
b	0.36	0.50	0.014	0.020
b1	0.36	0.45	0.014	0.018
c	0.14	0.20	0.006	0.008
c1	0.14	0.16	0.006	0.006
D	2.826	3.026	0.111	0.119
E	2.60	3.00	0.102	0.118
E1	1.526	1.726	0.060	0.068
e	0.90	1.00	0.035	0.039
e1	1.80	2.00	0.071	0.079
L	0.35	0.60	0.014	0.024
L1	0.59REF		0.023REF	
L2	0.25BSC		0.010BSC	
R	0.10	---	0.004	---
R1	0.10	0.25	0.004	0.010
θ	0°	8°	0°	8°
θ1	3°	7°	3°	7°
θ2	6°	14°	6°	14°

11.2. SOP8

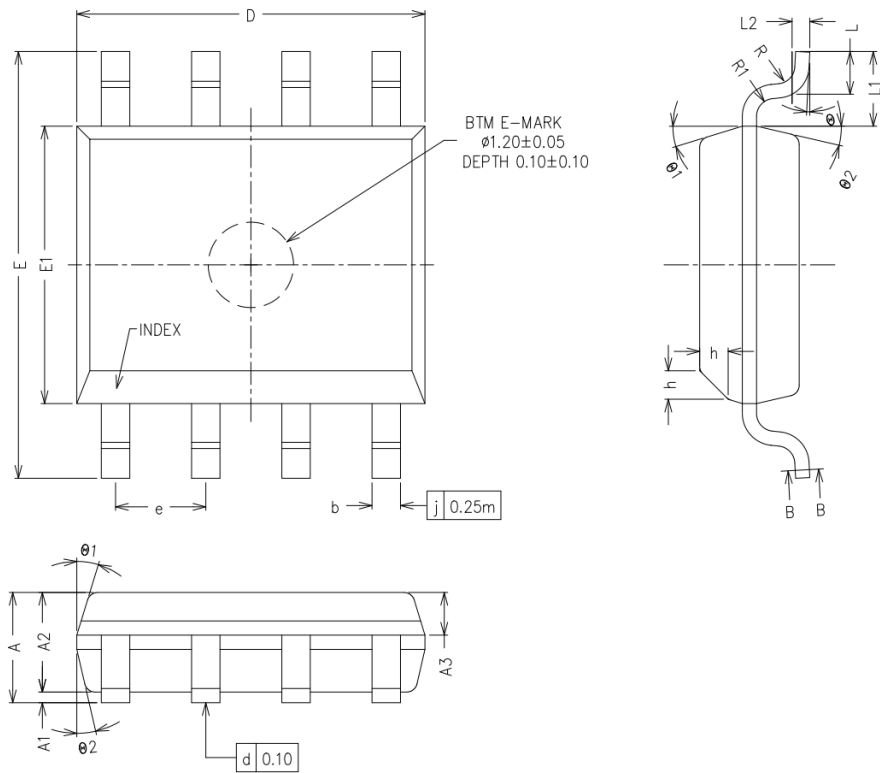

Symbol	Dimensions In Millimeters		Dimensions In Inches	
	Min	Max	Min	Max
A	---	1.75	---	0.069
A1	0.1	0.25	0.004	0.01
A2	1.30	1.50	0.051	0.059
A3	0.50	0.70	0.020	0.028
b	0.38	0.47	0.015	0.019
b1	0.37	0.40	0.015	0.016
D	4.80	5.00	0.189	0.197
E	5.80	6.20	0.228	0.244
E1	3.80	4.00	0.15	0.157
e	1.17	1.37	0.046	0.054
L	0.45	0.80	0.018	0.031
L1	1.04REF		0.041REF	
L2	0.25BSC		0.010BSC	
R	0.07	---	0.003	---
R1	0.07	---	0.003	---
h	0.30	0.50	0.012	0.020
θ	0°	8°	0°	8°
θ1	15°	19°	15°	19°
θ2	11°	15°	11°	15°

11.3. MSOP8

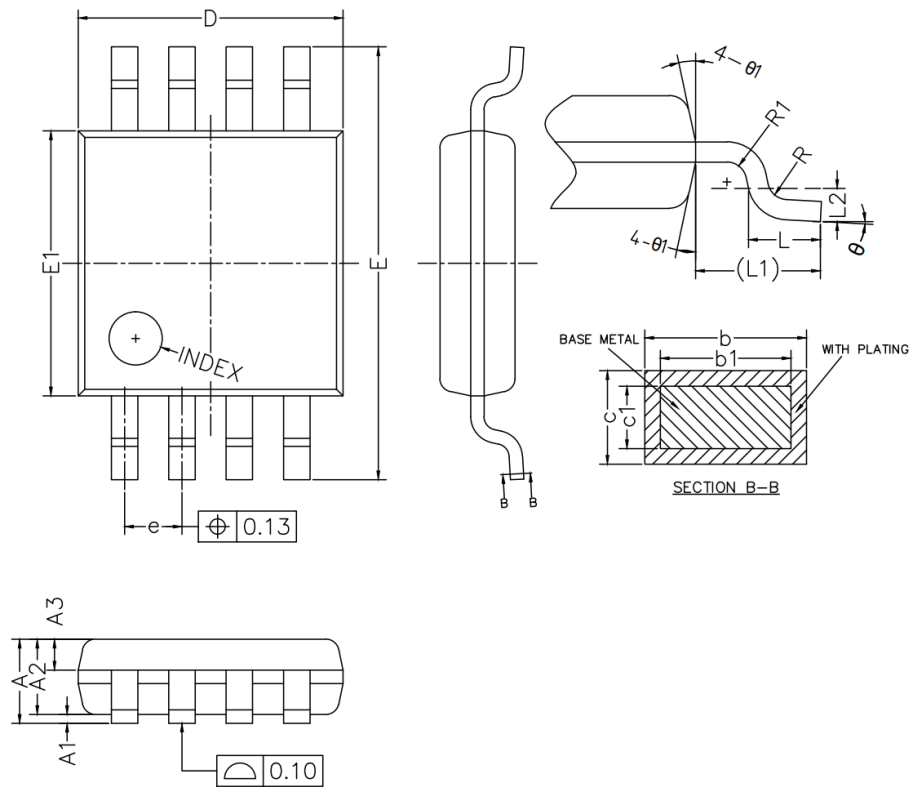

Symbol	Dimensions In Millimeters		Dimensions In Inches	
	Min	Max	Min	Max
A	—	1.10	—	0.043
A1	0.05	0.15	0.002	0.006
A2	0.75	0.95	0.030	0.037
A3	0.30	0.40	0.012	0.016
b	0.25	0.38	0.010	0.015
b1	0.24	0.33	0.009	0.013
c	0.15	0.20	0.006	0.008
c1	0.14	0.16	0.006	0.0062
D	2.90	3.10	0.114	0.122
E	4.75	5.05	0.187	0.199
E1	2.90	3.10	0.114	0.122
e	0.55	0.75	0.022	0.030
L	0.40	0.70	0.016	0.028
L1	0.95REF		0.037(BSC)	
L2	0.25BSC		0.010	
R	0.07	—	0°	8°
R1	0.07	—	0.003	—
θ	0°	8°	0°	8°
θ1	9°	15°	9°	15°

11.4. SOP14

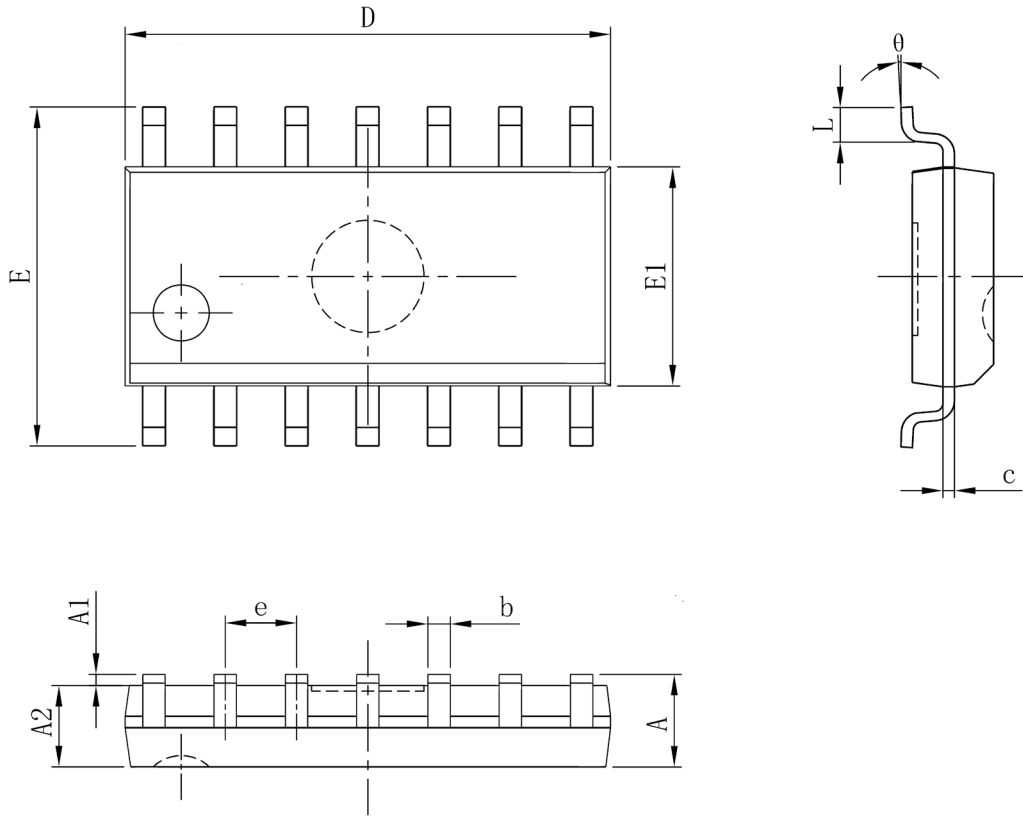

Symbol	Dimensions In Millimeters		Dimensions In Inches	
	Min	Max	Min	Max
A	—	1.75	—	0.069
A1	0.1	0.25	0.004	0.01
A2	1.25	—	0.049	—
b	0.31	0.51	0.012	0.02
c	0.1	0.25	0.004	0.01
D	8.45	8.85	0.333	0.348
E	5.8	6.2	0.228	0.244
E1	3.8	4	0.15	0.157
e	1.270(BSC)		0.050(BSC)	
L	0.4	0.016	0.016	0.05
θ	0°	0°	0°	8°

11.5. TSSOP14

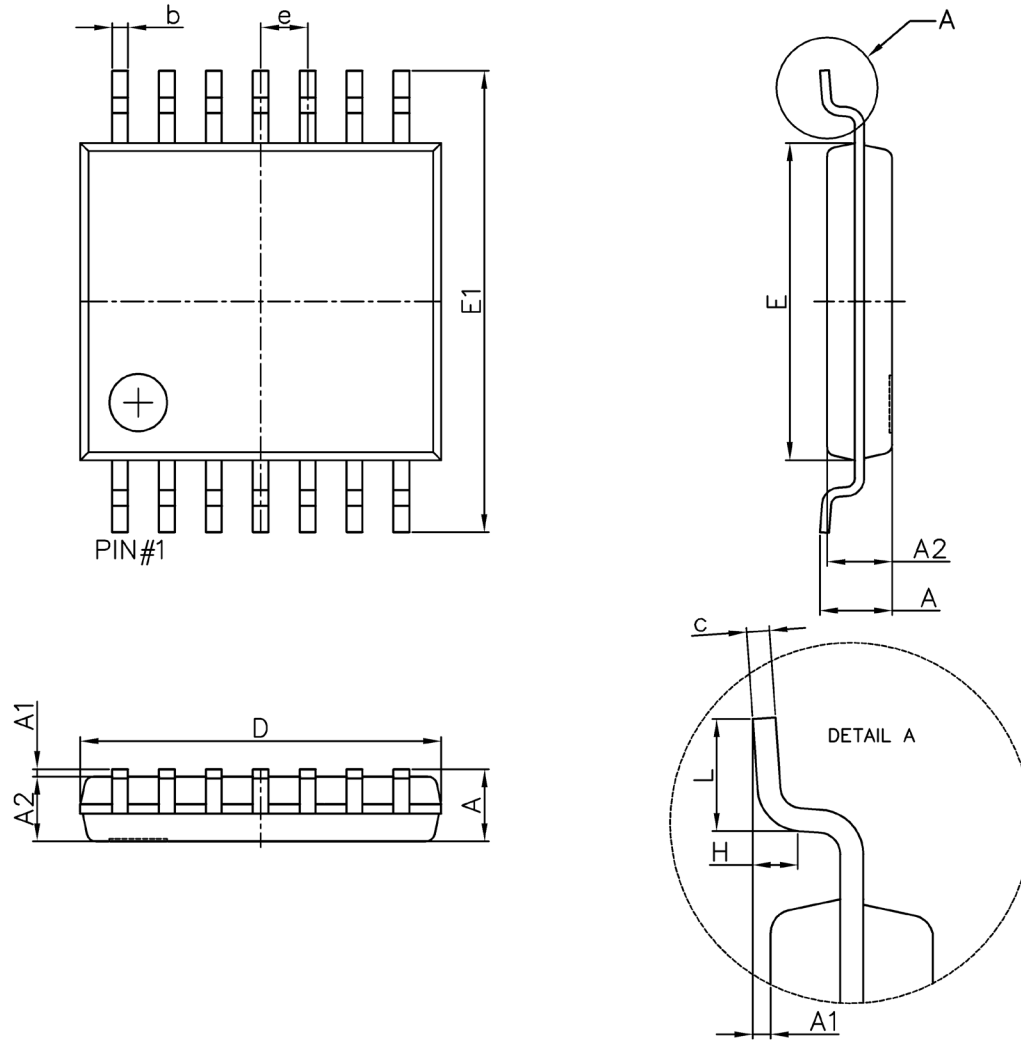

Symbol	Dimensions In Millimeters		Dimensions In Inches	
	Min.	Max.	Min.	Max.
D	4.9	5.1	0.193	0.201
E	4.3	4.5	0.169	0.177
b	0.19	0.3	0.007	0.012
c	0.09	0.2	0.004	0.008
E1	6.25	6.55	0.246	0.258
A	—	1.2	—	0.047
A2	0.8	1	0.031	0.039
A1	0.05	0.15	0.002	0.006
e	0.65 (BSC)		0.026 (BSC)	
L	0.5	0.7	0.02	0.028
H	0.25(TYP)		0.01(TYP)	
$\theta$	1°	7°	1°	7°

## 12. Ordering Information

<i>Part Number</i>	<i>Package</i>	<i>MSL Level</i>	<i>Op Temp (°C)</i>	<i>SPQ</i>
NSOPA9011-Q1STAR	SOT23-5L	1	-40~+125	3000
NSOPA9011-Q1SPR	SOP8	1	-40~+125	2500
NSOPA9012-Q1SPR	SOP8	1	-40~+125	2500
NSOPA9012-Q1MSR	MSOP8	1	-40~+125	2500
NSOPA9014-Q1SPKR	SOP14	1	-40~+125	2500
NSOPA9014-Q1TSKR	TSSOP14	1	-40~+125	4000

Note: All packages are ROHS compliant with peak reflow temperature of 260°C according to the JEDEC industry standard classifications and peak solder temperature.

### 13. Tape and Reel Information

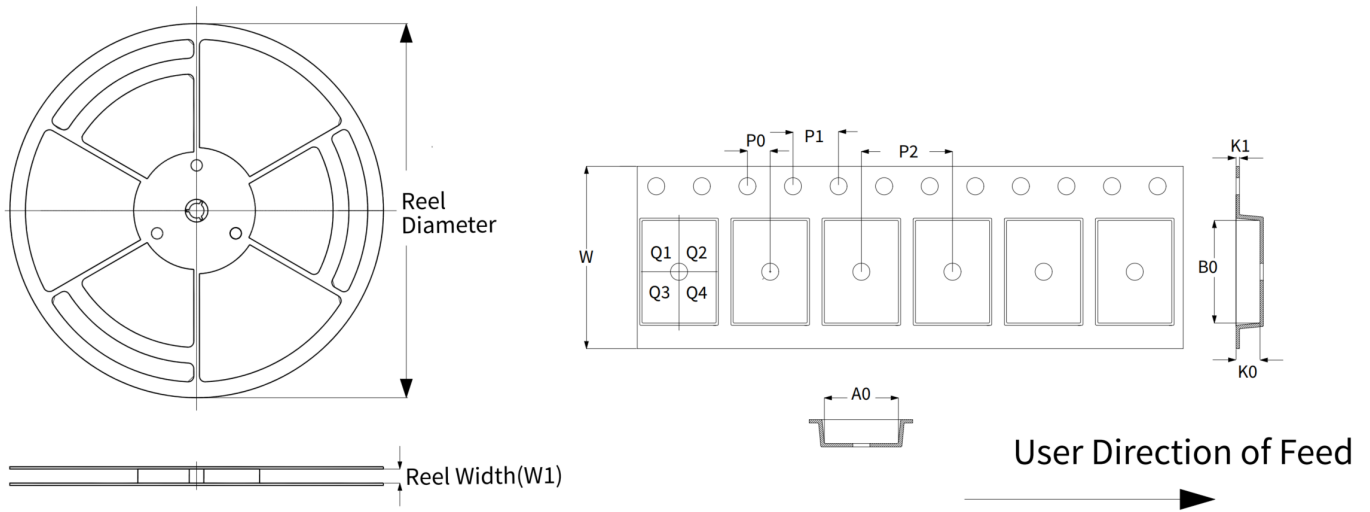

Device	Reel Diameter	Reel Width(W1)	W	A0	B0	P0	P1	P2	K0	K1	PIN1 Quadrant
NSOPA9011-Q1STAR	178	8.4	8.0	3.3	3.2	2.0	4.0	4.0	1.4	0.23	Q3
NSOPA9011-Q1SPR	330	12.4	12.0	6.6	5.5	2.0	4.0	8.0	2.1	0.3	Q1
NSOPA9012-Q1SPR	330	12.4	12.0	6.6	5.5	2.0	4.0	8.0	2.1	0.3	Q1
NSOPA9012-Q1MSR	330	12.4	12.0	5.25	3.35	2.0	4.0	8.0	1.25	0.3	Q1
NSOPA9014-Q1SPKR	330	16.4	16.0	6.60	9.3	2.0	4.0	8.0	2.1	0.3	Q1
NSOPA9014-Q1TSKR	330	16.4	12.0	6.85	5.4	2.0	4.0	8.0	1.6	0.3	Q1

Note:

1. All dimensions are nominal.
2. The picture is only for reference. Please make the object as the standard.
3. Unit: mm.

## 14. Revision History

Revision	Description	Date
1.0	Initial Version.	2024/12

### IMPORTANT NOTICE

The information given in this document (the "Document") shall in no event be regarded as any warranty or authorization of, express or implied, including but not limited to accuracy, completeness, merchantability, fitness for a particular purpose or infringement of any third party's intellectual property rights.

Users of this Document shall be solely responsible for the use of NOVOSENSE's products and applications, and for the safety thereof. Users shall comply with all laws, regulations and requirements related to NOVOSENSE's products and applications, although information or support related to any application may still be provided by NOVOSENSE.

This Document is provided on an "AS IS" basis, and is intended only for skilled developers designing with NOVOSENSE's products. NOVOSENSE reserves the rights to make corrections, modifications, enhancements, improvements or other changes to the products and services provided without notice. NOVOSENSE authorizes users to use this Document exclusively for the development of relevant applications or systems designed to integrate NOVOSENSE's products. No license to any intellectual property rights of NOVOSENSE is granted by implication or otherwise. Using this Document for any other purpose, or any unauthorized reproduction or display of this Document is strictly prohibited. In no event shall NOVOSENSE be liable for any claims, damages, costs, losses or liabilities arising out of or in connection with this Document or the use of this Document.

For further information on applications, products and technologies, please contact NOVOSENSE ([www.novosns.com](http://www.novosns.com)).

**Suzhou NOVOSENSE Microelectronics Co., Ltd**