

## Product Overview

The NSIP954x devices are quad-channel digital isolators with integrated isolated DC-DC converter. The isolated DC-DC converter provides up to 500mW output power using on-chip transformer. The feedback PWM signal is sent to primary side by a digital isolator based on Novosense capacity isolation technology. The high integrated solution can help to simplify system design and improve reliability. The NSIP954x devices are safety certified by UL1577, supporting 5.0kVrms withstand voltage, while providing high electromagnetic immunity and low emissions. The data rate of the NSIP954x is up to 150Mbps, and the common-mode transient immunity (CMTI) is up to 100kV/us. The NSIP954x devices provide 5V to 5V, 5V to 3.3V, 3.3V to 3.3V conversion mode, the output voltage can be set by SEL pin.

## Key Features

- AEC Q-100 Qualified for Grade 1: TA from -40 °C to 125 °C
- Up to 5000Vrms Insulation voltage
- Power supply voltage: 3V to 5.25V
- 5V to 5V, 5V to 3.3V, support 100mA load current
- 3.3V to 3.3V, support 60mA load current
- Over current and over temperature protection
- Data rate: DC to 150Mbps
- High CMTI: 100kV/us
- High system level EMC performance:  
Enhanced system level ESD, EFT, Surge immunity
- Operation temperature: -40°C~125°C
- RoHS-compliant packages: SOW16

## Safety Regulatory Approvals

- UL recognition: up to 5000V<sub>rms</sub> for 1 minute per UL1577
- CQC certification per GB4943.1
- CSA component notice 5A
- DIN VDE V 0884-17

## Applications

- Battery Management System
- Isolated SPI, RS232, RS485
- General-purpose multichannel isolation

## Device Information

Part Number	Package	Body Size
NSIP954x-Q1SWR	SOW16	10.30mm × 7.50mm

## Functional Block Diagrams

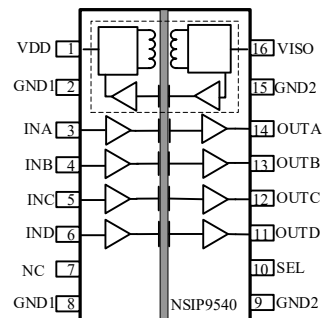

Figure 1. NSIP954x Block Diagram<sup>1</sup>

<sup>1</sup> The isolation channel direction can be either depend on different part number.

## INDEX

<b>1. PIN CONFIGURATION AND FUNCTIONS</b> .....	<b>3</b>
<b>2. ABSOLUTE MAXIMUM RATINGS<sup>1</sup></b> .....	<b>5</b>
<b>3. ESD RATINGS</b> .....	<b>5</b>
<b>4. RECOMMENDED OPERATING CONDITIONS</b> .....	<b>5</b>
<b>5. THERMAL CHARACTERISTICS</b> .....	<b>6</b>
<b>6. SPECIFICATIONS</b> .....	<b>6</b>
6.1. ISOLATED DC/DC CONVERTER STATIC SPECIFICATIONS .....	6
6.2. DIGITAL ISOLATOR ELECTRICAL CHARACTERISTICS .....	8
6.3. TYPICAL PERFORMANCE CHARACTERISTICS .....	15
6.4. PARAMETER MEASUREMENT INFORMATION .....	15
<b>7. HIGH VOLTAGE FEATURE DESCRIPTION</b> .....	<b>16</b>
7.1. INSULATION AND SAFETY RELATED SPECIFICATIONS .....	16
7.2. INSULATION CHARACTERISTICS .....	17
7.3. REGULATORY INFORMATION .....	18
<b>8. FUNCTION DESCRIPTION</b> .....	<b>19</b>
8.1. OVERVIEW .....	19
8.2. DEVICE FUNCTIONAL MODES .....	19
8.3. OUTPUT SHORT AND OVER TEMPERATURE PROTECTION .....	19
<b>9. APPLICATION NOTE</b> .....	<b>20</b>
9.1. TYPICAL APPLICATION .....	20
9.2. PCB LAYOUT .....	21
<b>10. PACKAGE INFORMATION</b> .....	<b>21</b>
<b>11. ORDER INFORMATION</b> .....	<b>22</b>
<b>12. DOCUMENTATION SUPPORT</b> .....	<b>23</b>
<b>13. TAPE AND REEL INFORMATION</b> .....	<b>24</b>
<b>14. REVISION HISTORY</b> .....	<b>25</b>

# 1. Pin Configuration And Functions

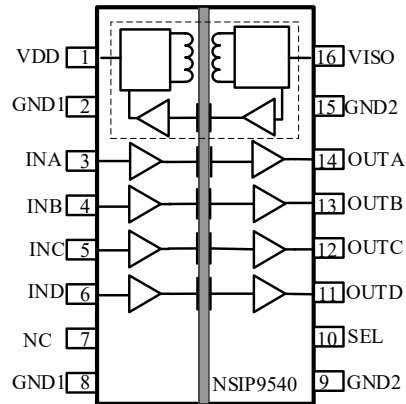

Figure 1.1 NSIP9540 Package

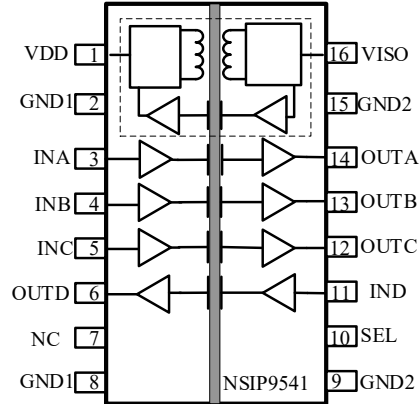

Figure 1.2 NSIP9541 Package

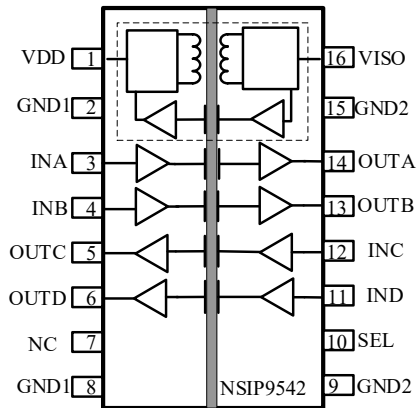

Figure 1.3 NSIP9542 Package

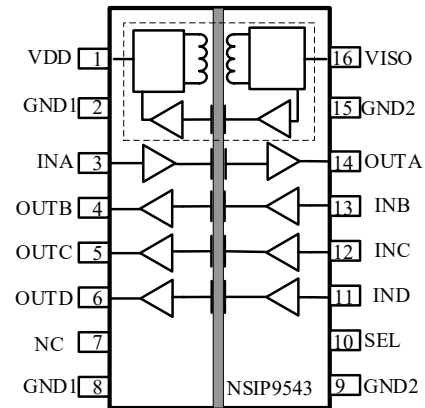

Figure 1.4 NSIP9543 Package

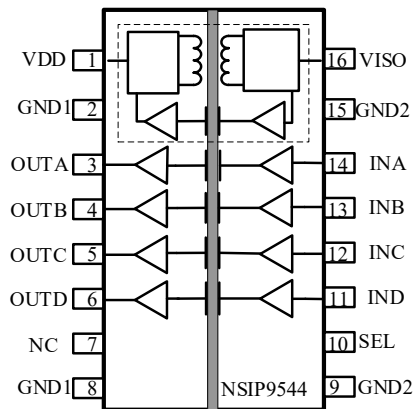

Figure 1.5 NSIP9544 Package

Table1.1 NSIP9540/ NSIP9541/ NSIP9542/ NSIP9543/NSIP9544 Pin Configuration and Description

NSIP9540 PIN NO.	NSIP9541 PIN NO.	NSIP9542 PIN NO.	NSIP9543 PIN NO.	NSIP9544 PIN NO.	SYMBOL	FUNCTION
1	1	1	1	1	VDD	Primary Supply Voltage.
2	2	2	2	2	GND1	Ground 1. Ground reference for Isolator Side primary. Pin 2 and Pin 8 are not internally connected. It is required that pin2 and pin8 be connected to a common ground.
3	3	3	3	14	INA	Logic Input A.
4	4	4	13	13	INB	Logic Input B.
5	5	12	12	12	INC	Logic Input C.
6	11	11	11	11	IND	Logic Input D.
7	7	7	7	7	NC	Not connected.
8	8	8	8	8	GND1	Ground 1. Ground reference for Isolator Side primary. Pin 2 and Pin 8 are not internally connected. It is required that pin2 and pin8 be connected to a common ground.
9	9	9	9	9	GND2	Ground 2. Ground reference for Isolator Side 2. Pin 9 and Pin 15 are internally connected. It is recommended that pin9 and pin16 be connected to a common ground.
10	10	10	10	10	SEL	VISO output voltage selection. VISO=5V when SEL short to VISO, VISO=3.3V when SEL short to GND2 or floating.
11	6	6	6	6	OUTD	Logic Output D.
12	12	5	5	5	OUTC	Logic Output C.
13	13	13	4	4	OUTB	Logic Output B.
14	14	14	14	3	OUTA	Logic Output A.
15	15	15	15	15	GND2	Ground 2. Ground reference for Isolator Side 2. Pin 9 and Pin 15 are internally connected. It is recommended that pin9 and pin16 be connected to a common ground.
16	16	16	16	16	VISO	Secondary Supply Voltage Output for External Loads.

## 2. Absolute Maximum Ratings<sup>1</sup>

Parameter	Symbol	Min	Typ	Max	Unit	Comments
Power Supply Voltage <sup>2</sup>	V <sub>DD</sub> , V <sub>ISO</sub>	-0.5		6	V	
Voltage at IN <sub>x</sub> , OUT <sub>x</sub> , SEL pins <sup>2</sup>	V <sub>INA</sub> , V <sub>INB</sub> V <sub>INC</sub> , V <sub>IND</sub> , V <sub>OUTA</sub> , V <sub>OUTB</sub> V <sub>OUTC</sub> , V <sub>OUTD</sub> V <sub>SEL</sub>	-0.5		V <sub>DD</sub> +0.5 V <sub>ISO</sub> +0.5 <sup>3</sup>	V	
Logic output current	I <sub>o</sub>	-15		15	mA	
Junction Temperature	T <sub>J</sub>	-40		150	°C	
Storage Temperature	T <sub>stg</sub>	-40		150	°C	

<sup>1</sup>Stresses beyond those listed under Absolute Maximum Ratings may cause permanent damage to the device. These are stress ratings only, which do not imply functional operation of the device at these or any other conditions beyond those indicated under Recommended Operating Conditions. Exposure to absolute-maximum-rated conditions for extended periods may affect device reliability.

<sup>2</sup>All voltage values are with respect to the local ground pin (GND1 or GND2) and are peak voltage values.

<sup>3</sup>This value depends on whether the pin is located on the V<sub>DD</sub> or V<sub>ISO</sub> side. The maximum voltage at the I/O pins should not exceed 6 V.

## 3. ESD Ratings

	Ratings	Value	Unit
Electrostatic discharge	Human body model (HBM), per AEC-Q100-002-RevD	±8.0	kV
	Charged device model (CDM), per AEC-Q100-011-RevB	±2.0	kV

## 4. Recommended Operating Conditions

Parameters	Symbol	min	typ	max	unit
Power Supply Voltage	V <sub>DD</sub> @ V <sub>SEL</sub> = 0V/Floating	3		5.25	V
	V <sub>DD</sub> @ V <sub>SEL</sub> = V <sub>ISO</sub>	4.5		5.25	V
High level output current	I <sub>OH</sub> @ V <sub>DO</sub> <sup>1</sup> = 5V	-4			mA
	I <sub>OH</sub> @ V <sub>DO</sub> <sup>1</sup> = 3.3V	-2			mA
Low level output current	I <sub>OL</sub> @ V <sub>DO</sub> <sup>1</sup> = 5V			4	mA
	I <sub>OL</sub> @ V <sub>DO</sub> <sup>1</sup> = 3.3V			2	mA
High Level Input Voltage	V <sub>IH</sub>	0.7* V <sub>DI</sub> <sup>1</sup>		V <sub>DI</sub> <sup>1</sup>	V

Parameters	Symbol	min	typ	max	unit
Low Level Input Voltage	V <sub>IL</sub>	0		0.3*V <sub>DI</sub> <sup>1</sup>	V
Data rate	DR			150	Mbps
Ambient temperature	T <sub>a</sub>	-40		125	°C

<sup>1</sup>V<sub>DI</sub> is the input side supply, V<sub>DO</sub> is the output side supply. This value depends on whether the pin is located on the VDD or VISO side.

## 5. Thermal Characteristics

Parameters	Symbol	SOW16	Unit
IC Junction-to-Air Thermal Resistance	θ <sub>JA</sub>	59.2	°C/W
Junction-to-case (top) thermal resistance	ψ <sub>JT</sub>	8.7	°C/W
Junction-to-board thermal resistance	ψ <sub>JB</sub>	23	°C/W

## 6. Specifications

### 6.1. Isolated DC/DC Converter Static Specifications

(V<sub>DD</sub>=4.5V~5.25V, SEL=V<sub>ISO</sub>, T<sub>a</sub>=-40°C to 125°C. Unless otherwise noted, Typical values are at V<sub>DD</sub> = 5V, T<sub>a</sub> = 25°C)

Parameters	Symbol	Min	Typ	Max	Unit	Comments
Isolated Supply Voltage	V <sub>ISO</sub>	4.6	5	5.25	V	I <sub>ISO</sub> = 0 to 100mA
Positive-going UVLO threshold on V <sub>DD</sub>	V <sub>DD+(UVLO)</sub>		2.7	3	V	
Negative-going UVLO threshold on V <sub>DD</sub>	V <sub>DD-(UVLO)</sub>	2.1	2.5		V	
UVLO threshold hysteresis on V <sub>DD</sub>	V <sub>HYS(UVLO)</sub>		0.2		V	
Line Regulation	V <sub>ISO(LINE)</sub>		2		mV/V	I <sub>ISO</sub> = 50mA, VDD= 4.5V to 5.25V
Load Regulation	V <sub>ISO(LOAD)</sub>		0.5		%	I <sub>ISO</sub> = 10 to 90mA
Output Ripple	V <sub>ISO(RIP)</sub>		70		mVpp	20MHz bandwidth, C <sub>LOAD</sub> = 0.1 μF    10 μF, I <sub>ISO</sub> = 100 mA
Efficiency at maximum load current	EFF		49		%	I <sub>ISO</sub> = 100mA, C <sub>LOAD</sub> = 0.1 μF    10 μF
Current available to isolated supply	I <sub>ISO</sub>	100			mA	
VDD supply current without digital isolator	I <sub>VDD_POWER</sub>		36	60	mA	No VISO Load
			200	265	mA	I <sub>ISO</sub> =100mA

( $V_{DD}=4.5V\sim 5.25V$ ,  $SEL=0V$ ,  $T_a=-40^{\circ}C$  to  $125^{\circ}C$ . Unless otherwise noted, Typical values are at  $V_{DD} = 5V$ ,  $T_a = 25^{\circ}C$ )

Parameters	Symbol	Min	Typ	Max	Unit	Comments
Isolated Supply Voltage	$V_{ISO}$	3	3.3	3.5	V	$I_{ISO} = 0$ to 100mA
Positive-going UVLO threshold on $V_{DD}$	$V_{DD+(UVLO)}$		2.7	3	V	
Negative-going UVLO threshold on $V_{DD}$	$V_{DD-(UVLO)}$	2.1	2.5		V	
UVLO threshold hysteresis on $V_{DD}$	$V_{HYS(UVLO)}$		0.2		V	
Line Regulation	$V_{ISO(LINE)}$		2		mV/V	$I_{ISO} = 50mA$ , $V_{DD} = 4.5V$ to $5.25V$
Load Regulation	$V_{ISO(LOAD)}$		0.5		%	$I_{ISO} = 10$ to 90mA
Output Ripple	$V_{ISO(RIP)}$		70		mVpp	20MHz bandwidth, $C_{LOAD} = 0.1\mu F \parallel 10\mu F$ , $I_{ISO} = 100mA$
Efficiency at maximum load current	EFF		40		%	$I_{ISO} = 100mA$ , $C_{LOAD} = 0.1\mu F \parallel 10\mu F$
Current available to isolated supply	$I_{ISO}$	100			mA	
VDD supply current without digital isolator	$I_{VDD\_POWER}$		32	55	mA	No $V_{ISO}$ Load
			165	230	mA	$I_{ISO}=100mA$

( $V_{DD}=3V\sim 3.6V$ ,  $SEL=0V$ ,  $T_a=-40^{\circ}C$  to  $125^{\circ}C$ . Unless otherwise noted, Typical values are at  $V_{DD} = 3.3V$ ,  $T_a = 25^{\circ}C$ )

Parameters	Symbol	Min	Typ	Max	Unit	Comments
Isolated Supply Voltage	$V_{ISO}$	3	3.3	3.5	V	$I_{ISO} = 0$ to 60mA
Positive-going UVLO threshold on $V_{DD}$	$V_{DD+(UVLO)}$		2.7	3	V	
Negative-going UVLO threshold on $V_{DD}$	$V_{DD-(UVLO)}$	2.1	2.5		V	
UVLO threshold hysteresis on $V_{DD}$	$V_{HYS(UVLO)}$		0.2		V	
Line Regulation	$V_{ISO(LINE)}$		3		mV/V	$I_{ISO} = 30mA$ , $V_{DD} = 3V$ to $3.6V$
Load Regulation	$V_{ISO(LOAD)}$		1		%	$I_{ISO} = 6$ to 54mA
Output Ripple	$V_{ISO(RIP)}$		45		mVpp	20MHz bandwidth, $C_{LOAD} = 0.1\mu F \parallel 10\mu F$ , $I_{ISO} = 60mA$
Efficiency at maximum load current	EFF		48		%	$I_{ISO} = 60mA$ , $C_{LOAD} = 0.1\mu F \parallel 10\mu F$
Current available to isolated supply	$I_{ISO}$	60			mA	
VDD supply current without digital isolator	$I_{VDD\_POWER}$		35	60	mA	No $V_{ISO}$ Load
			131	170	mA	$I_{ISO}=60mA$

## 6.2. Digital Isolator Electrical Characteristics

Parameters	Symbol	Min	Typ	Max	Unit	Comments
Input pin rising threshold	$V_{ITH}$	$0.7 \cdot V_{DI}^1$			V	
Input pin falling threshold	$V_{ITL}$			$0.3 \cdot V_{DI}^1$	V	
Input pin threshold hysteresis	$V_{I(UVLO)}$	$0.1 \cdot V_{DI}^1$			V	
High level input current	$I_{IH}$		8	15	$\mu A$	$V_I = V_{DI}^1$ at INx or SEL
Low level input current	$I_{IL}$	-15	-8		$\mu A$	$V_I = 0$ at INx or SEL
High Level Output Voltage	$V_{OH}$	$V_{DO}^1 - 0.4$			V	$V_{DO}^1 = 5V$ , $I_{OH} \geq -4mA$
		$V_{DO}^1 - 0.3$			V	$V_{DO}^1 = 3.3V$ , $I_{OH} \geq -2mA$
Low Level Output Voltage	$V_{OL}$			0.4	V	$V_{DO}^1 = 5V$ , $I_{OL} \leq 4mA$
				0.3	V	$V_{DO}^1 = 3.3V$ , $I_{OL} \leq 2mA$
Output Impedance	$R_{out}$		50		ohm	
Common Mode Transient Immunity	CMTI	100	150		$kV/\mu s$	$V_I = V_{DI}^1$ or 0 V
Thermal Shutdown Temperature			165		$^{\circ}C$	

<sup>1</sup> $V_{DI}$  is the input side supply,  $V_{DO}$  is the output side supply. This value depends on whether the pin is located on the VDD or VISO side.

(V<sub>DD</sub>=4.5V~5.25V, SEL=V<sub>ISO</sub>, T<sub>a</sub>=-40°C to 125°C. Unless otherwise noted, Typical values are at V<sub>DD</sub> = 5V, T<sub>a</sub> = 25°C)

Parameters	Symbol	Min	Typ	Max	Unit	Comments
Supply Current	NSIP9540					
	I <sub>DD(Q0)</sub>		35		mA	All Input 0V for NSIP9540W0 or All Input at supply for NSIP9540W1
	I <sub>DD(Q1)</sub>		38		mA	All Input at supply for NSIP9540W0 or All Input 0V for NSIP9540W1
	I <sub>DD(1M)</sub>		35		mA	All Input with 1Mbps square wave, C <sub>L</sub> =15pF
	I <sub>DD(10M)</sub>		39		mA	All Input with 10Mbps square wave, C <sub>L</sub> =15pF
	I <sub>DD(100M)</sub>		70		mA	All Input with 100Mbps square wave, C <sub>L</sub> =15pF
	NSIP9541					
	I <sub>DD(Q0)</sub>		36		mA	All Input 0V for NSIP9541W0 or All Input at supply for NSIP9541W1
	I <sub>DD(Q1)</sub>		40		mA	All Input at supply for NSIP9541W0 or All Input 0V for NSIP9541W1
	I <sub>DD(1M)</sub>		38		mA	All Input with 1Mbps square wave, C <sub>L</sub> =15pF
	I <sub>DD(10M)</sub>		42		mA	All Input with 10Mbps square wave, C <sub>L</sub> =15pF
	I <sub>DD(100M)</sub>		74		mA	All Input with 100Mbps square wave, C <sub>L</sub> =15pF
	NSIP9542					
	I <sub>DD(Q0)</sub>		37		mA	All Input 0V for NSIP9542W0 or All Input at supply for NSIP9542W1
	I <sub>DD(Q1)</sub>		42		mA	All Input at supply for NSIP9542W0 or All Input 0V for NSIP9542W1
	I <sub>DD(1M)</sub>		41		mA	All Input with 1Mbps square wave, C <sub>L</sub> =15pF
	I <sub>DD(10M)</sub>		45		mA	All Input with 10Mbps square wave, C <sub>L</sub> =15pF
	I <sub>DD(100M)</sub>		78		mA	All Input with 100Mbps square wave, C <sub>L</sub> =15pF
Supply Current	NSIP9543					
	I <sub>DD(Q0)</sub>		38		mA	All Input 0V for NSIP9543W0 or All Input at supply for NSIP9543W1
	I <sub>DD(Q1)</sub>		44		mA	All Input at supply for NSIP9543W0 or All Input 0V for NSIP9543W1
	I <sub>DD(1M)</sub>		44		mA	All Input with 1Mbps square wave, C <sub>L</sub> =15pF

Parameters	Symbol	Min	Typ	Max	Unit	Comments
	I <sub>DD(10M)</sub>		48		mA	All Input with 10Mbps square wave, C <sub>L</sub> =15pF
	I <sub>DD(100M)</sub>		82		mA	All Input with 100Mbps square wave, C <sub>L</sub> =15pF
	NSIP9544					
	I <sub>DD(Q0)</sub>		39		mA	All Input 0V for NSIP9544W0 or All Input at supply for NSIP9544W1
	I <sub>DD(Q1)</sub>		46		mA	All Input at supply for NSIP9544W0 or All Input 0V for NSIP9544W1
	I <sub>DD(1M)</sub>		47		mA	All Input with 1Mbps square wave, C <sub>L</sub> =15pF
	I <sub>DD(10M)</sub>		51		mA	All Input with 10Mbps square wave, C <sub>L</sub> =15pF
	I <sub>DD(100M)</sub>		86		mA	All Input with 100Mbps square wave, C <sub>L</sub> =15pF
Data Rate	DR	0		150	Mbps	
Minimum Pulse Width	PW			5.0	ns	
Propagation Delay	t <sub>PLH</sub>		10	25	ns	
	t <sub>PHL</sub>		10	25	ns	
Pulse Width Distortion	PWD			10	ns	t <sub>PHL</sub> - t <sub>PLH</sub>
Rising Time	t <sub>r</sub>			5	ns	C <sub>L</sub> = 15pF
Falling Time	t <sub>f</sub>			5	ns	C <sub>L</sub> = 15pF
Channel-to-Channel Delay Skew	t <sub>SK(c2c)</sub>			2.5	ns	
Part-to-Part Delay Skew	t <sub>SK(p2p)</sub>			5	ns	

(V<sub>DD</sub>=4.5V~5.25V, SEL=0V, T<sub>a</sub>=-40°C to 125°C. Unless otherwise noted, Typical values are at V<sub>DD</sub> = 5V, T<sub>a</sub> = 25°C)

Parameters	Symbol	Min	Typ	Max	Unit	Comments
Supply Current	NSIP9540					
	I <sub>DD(Q0)</sub>		32		mA	All Input 0V for NSIP9540W0 or All Input at supply for NSIP9540W1
	I <sub>DD(Q1)</sub>		36		mA	All Input at supply for NSIP9540W0 or All Input 0V for NSIP9540W1
	I <sub>DD(1M)</sub>		35		mA	All Input with 1Mbps square wave, C <sub>L</sub> =15pF
	I <sub>DD(10M)</sub>		34		mA	All Input with 10Mbps square wave, C <sub>L</sub> =15pF
	I <sub>DD(100M)</sub>		50		mA	All Input with 100Mbps square wave, C <sub>L</sub> =15pF
	NSIP9541					
	I <sub>DD(Q0)</sub>		32		mA	All Input 0V for NSIP9541W0 or All Input at supply for NSIP9541W1
	I <sub>DD(Q1)</sub>		36		mA	All Input at supply for NSIP9541W0 or All Input 0V for NSIP9541W1
	I <sub>DD(1M)</sub>		35		mA	All Input with 1Mbps square wave, C <sub>L</sub> =15pF
	I <sub>DD(10M)</sub>		36		mA	All Input with 10Mbps square wave, C <sub>L</sub> =15pF
	I <sub>DD(100M)</sub>		53		mA	All Input with 100Mbps square wave, C <sub>L</sub> =15pF
	NSIP9542					
	I <sub>DD(Q0)</sub>		32		mA	All Input 0V for NSIP9542W0 or All Input at supply for NSIP9542W1
	I <sub>DD(Q1)</sub>		36		mA	All Input at supply for NSIP9542W0 or All Input 0V for NSIP9542W1
I <sub>DD(1M)</sub>		35		mA	All Input with 1Mbps square wave, C <sub>L</sub> =15pF	
I <sub>DD(10M)</sub>		38		mA	All Input with 10Mbps square wave, C <sub>L</sub> =15pF	
I <sub>DD(100M)</sub>		56		mA	All Input with 100Mbps square wave, C <sub>L</sub> =15pF	
Supply Current	NSIP9543					
	I <sub>DD(Q0)</sub>		32		mA	All Input 0V for NSIP9543W0 or All Input at supply for NSIP9543W1
	I <sub>DD(Q1)</sub>		36		mA	All Input at supply for NSIP9543W0 or All Input 0V for NSIP9543W1
	I <sub>DD(1M)</sub>		35		mA	All Input with 1Mbps square wave, C <sub>L</sub> =15pF

Parameters	Symbol	Min	Typ	Max	Unit	Comments
	I <sub>DD(10M)</sub>		40		mA	All Input with 10Mbps square wave, C <sub>L</sub> =15pF
	I <sub>DD(100M)</sub>		59		mA	All Input with 100Mbps square wave, C <sub>L</sub> =15pF
NSIP9544						
	I <sub>DD(Q0)</sub>		32		mA	All Input 0V for NSIP9544W0 or All Input at supply for NSIP9544W1
	I <sub>DD(Q1)</sub>		36		mA	All Input at supply for NSIP9544W0 or All Input 0V for NSIP9544W1
	I <sub>DD(1M)</sub>		35		mA	All Input with 1Mbps square wave, C <sub>L</sub> =15pF
	I <sub>DD(10M)</sub>		42		mA	All Input with 10Mbps square wave, C <sub>L</sub> =15pF
	I <sub>DD(100M)</sub>		62		mA	All Input with 100Mbps square wave, C <sub>L</sub> =15pF
Data Rate	DR	0		150	Mbps	
Minimum Pulse Width	PW			5.0	ns	
Propagation Delay	t <sub>PLH</sub>		10	25	ns	
	t <sub>PHL</sub>		10	25	ns	
Pulse Width Distortion	PWD			5	ns	t <sub>PHL</sub> - t <sub>PLH</sub>
Rising Time	t <sub>r</sub>			5	ns	C <sub>L</sub> = 15pF
Falling Time	t <sub>f</sub>			5	ns	C <sub>L</sub> = 15pF
Channel-to-Channel Delay Skew	t <sub>SK(c2c)</sub>			2.5	ns	
Part-to-Part Delay Skew	t <sub>SK(p2p)</sub>			5	ns	

( $V_{DD}=3V\sim 3.6V$ ,  $SEL=0V$ ,  $T_a=-40^{\circ}C$  to  $125^{\circ}C$ . Unless otherwise noted, Typical values are at  $V_{DD} = 3.3V$ ,  $T_a = 25^{\circ}C$ )

Parameters	Symbol	Min	Typ	Max	Unit	Comments
Supply Current	NSIP9540					
	$I_{DD(Q0)}$		35		mA	All Input 0V for NSIP9540W0 or All Input at supply for NSIP9540W1
	$I_{DD(Q1)}$		40		mA	All Input at supply for NSIP9540W0 or All Input 0V for NSIP9540W1
	$I_{DD(1M)}$		38		mA	All Input with 1Mbps square wave, $C_L=15pF$
	$I_{DD(10M)}$		40		mA	All Input with 10Mbps square wave, $C_L=15pF$
	$I_{DD(100M)}$		55		mA	All Input with 100Mbps square wave, $C_L=15pF$
	NSIP9541					
	$I_{DD(Q0)}$		36		mA	All Input 0V for NSIP9541W0 or All Input at supply for NSIP9541W1
	$I_{DD(Q1)}$		41		mA	All Input at supply for NSIP9541W0 or All Input 0V for NSIP9541W1
	$I_{DD(1M)}$		39		mA	All Input with 1Mbps square wave, $C_L=15pF$
	$I_{DD(10M)}$		41		mA	All Input with 10Mbps square wave, $C_L=15pF$
	$I_{DD(100M)}$		59		mA	All Input with 100Mbps square wave, $C_L=15pF$
	NSIP9542					
	$I_{DD(Q0)}$		37		mA	All Input 0V for NSIP9542W0 or All Input at supply for NSIP9542W1
	$I_{DD(Q1)}$		42		mA	All Input at supply for NSIP9542W0 or All Input 0V for NSIP9542W1
	$I_{DD(1M)}$		40		mA	All Input with 1Mbps square wave, $C_L=15pF$
	$I_{DD(10M)}$		42		mA	All Input with 10Mbps square wave, $C_L=15pF$
	$I_{DD(100M)}$		63		mA	All Input with 100Mbps square wave, $C_L=15pF$
Supply Current	NSIP9543					
	$I_{DD(Q0)}$		38		mA	All Input 0V for NSIP9543W0 or All Input at supply for NSIP9543W1
	$I_{DD(Q1)}$		43		mA	All Input at supply for NSIP9543W0 or All Input 0V for NSIP9543W1
	$I_{DD(1M)}$		41		mA	All Input with 1Mbps square wave, $C_L=15pF$

Parameters	Symbol	Min	Typ	Max	Unit	Comments
	I <sub>DD(10M)</sub>		43		mA	All Input with 10Mbps square wave, C <sub>L</sub> =15pF
	I <sub>DD(100M)</sub>		67		mA	All Input with 100Mbps square wave, C <sub>L</sub> =15pF
	NSIP9544					
	I <sub>DD(Q0)</sub>		39		mA	All Input 0V for NSIP9544W0 or All Input at supply for NSIP9544W1
	I <sub>DD(Q1)</sub>		44		mA	All Input at supply for NSIP9544W0 or All Input 0V for NSIP9544W1
	I <sub>DD(1M)</sub>		42		mA	All Input with 1Mbps square wave, C <sub>L</sub> =15pF
	I <sub>DD(10M)</sub>		44		mA	All Input with 10Mbps square wave, C <sub>L</sub> =15pF
	I <sub>DD(100M)</sub>		71		mA	All Input with 100Mbps square wave, C <sub>L</sub> =15pF
Data Rate	DR	0		150	Mbps	
Minimum Pulse Width	PW			5.0	ns	
Propagation Delay	t <sub>PLH</sub>		10	25	ns	
	t <sub>PHL</sub>		10	25	ns	
Pulse Width Distortion	PWD			5	ns	t <sub>PHL</sub> - t <sub>PLH</sub>
Rising Time	t <sub>r</sub>			5	ns	C <sub>L</sub> = 15pF
Falling Time	t <sub>f</sub>			5	ns	C <sub>L</sub> = 15pF
Channel-to-Channel Delay Skew	t <sub>SK(c2c)</sub>			2.5	ns	
Part-to-Part Delay Skew	t <sub>SK(p2p)</sub>			5	ns	

### 6.3. Typical Performance Characteristics

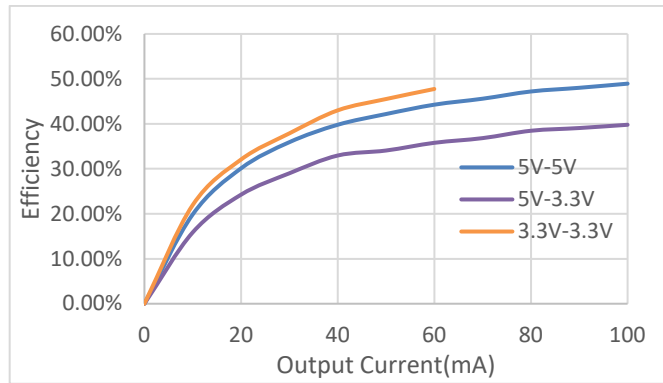

Figure 6.1 Output Current vs Efficiency

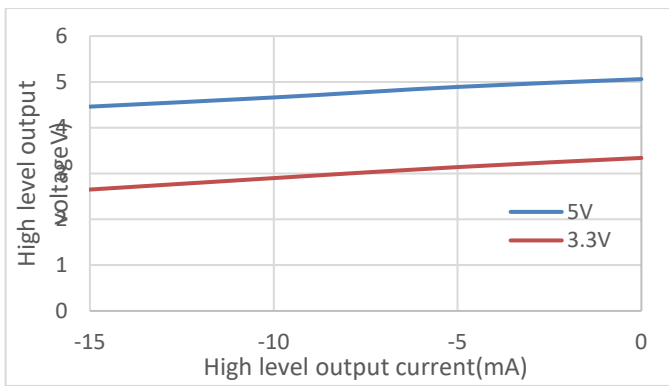

Figure 6.2 High-level Output Voltage vs Output Current

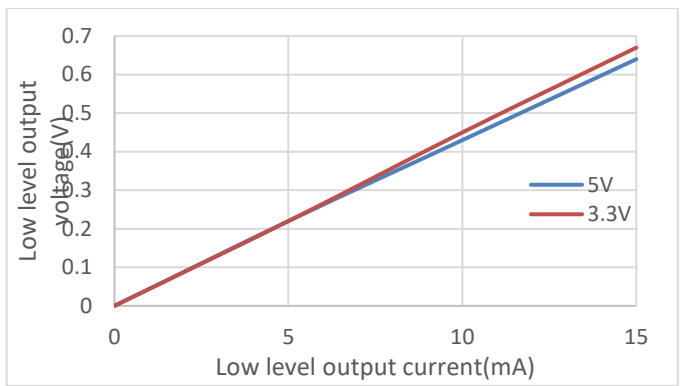

Figure 6.3 Low-level Output Voltage vs Output Current

### 6.4. Parameter Measurement Information

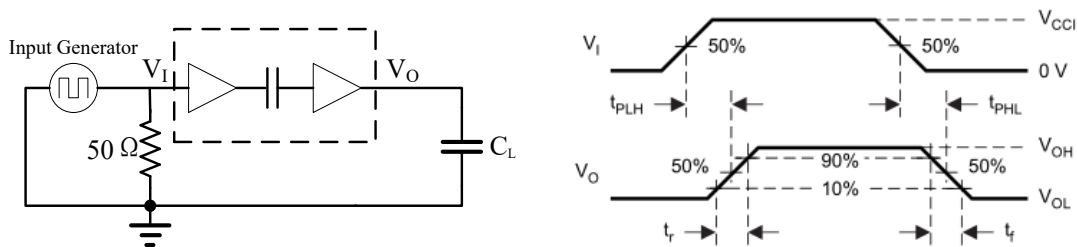

Figure 6.4 Switching Characteristics Test Circuit and Waveform

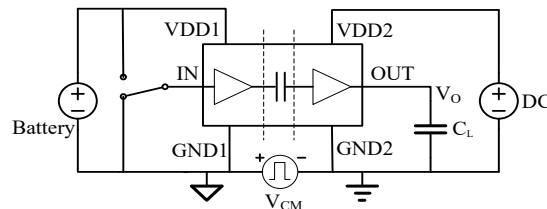

Figure 6.5 Common-Mode Transient Immunity Test Circuit

## 7. High Voltage Feature Description

### 7.1. Insulation and Safety Related Specifications

<i>Parameters</i>	<i>Symbol</i>	<i>Value</i>	<i>Unit</i>	<i>Comments</i>
Minimum External Air Gap (Clearance)	CLR	8.15	mm	Shortest terminal-to-terminal distance through air
Minimum External Tracking (Creepage)	CPG	8.15	mm	Shortest terminal-to-terminal distance across the package surface
Distance Through Insulation	DTI	26	μm	Distance through insulation
Tracking Resistance (Comparative Tracking Index)	CTI	>600	V	DIN EN 60112 (VDE 0303-11); IEC 60112
Material Group		I		IEC 60664-1

<i>Description</i>	<i>Test Condition</i>	<i>Value</i>
Overvoltage Category per IEC60664-1	For Rated Mains Voltage $\leq 150\text{Vrms}$	I to IV
	For Rated Mains Voltage $\leq 300\text{Vrms}$	I to IV
	For Rated Mains Voltage $\leq 600\text{Vrms}$	I to III
Climatic Classification		40/125/21
Pollution Degree per DIN VDE 0110,		2

7.2. Insulation Characteristics

Description	Test Condition	Symbol	Value	Unit
Maximum repetitive isolation voltage		$V_{IORM}$	1500	$V_{PEAK}$
Maximum working isolation voltage	AC Voltage	$V_{IOWM}$	1061	$V_{RMS}$
	DC Voltage		1500	$V_{DC}$
Apparent Charge	Method a, after Input/output safety test subgroup 2/3, $V_{ini}=V_{IOTM}$ , $t_{ini} = 60\text{ s}$ , $V_{pd(m)}=1.2*V_{IORM}$ , $t_m=10\text{s}$ .	$q_{pd}$	<5	pC
	Method a, after environmental tests subgroup 1, $V_{ini}=V_{IOTM}$ , $t_{ini}=60\text{s}$ , $V_{pd(m)}=1.6*V_{IORM}$ , $t_m=10\text{s}$			pC
	Method b, routine test (100% production) and preconditioning (type test); $V_{ini}=1.2*V_{IOTM}$ , $t_{ini}=1\text{s}$ $V_{pd(m)}=1.875*V_{IORM}$ , $t_m=1\text{s}$ (method b1) or $V_{pd(m)}=V_{ini}$ , $t_m=t_{ini}$ (method b2)			pC
Maximum transient isolation voltage	$t = 60\text{ sec}$	$V_{IOTM}$	7070	$V_{PEAK}$
Maximum impulse voltage	Tested in air, 1.2/50-us waveform per IEC62368-1	$V_{IMP}$	7600	$V_{PEAK}$
Maximum Surge Isolation Voltage	Test method per IEC62368-1, 1.2/50us waveform, $V_{IOSM} \geq V_{IMP} \times 1.3$	$V_{IOSM}$	10000	$V_{PEAK}$
Isolation resistance	$V_{IO} = 500\text{V}$ , $T_{amb}=25^\circ\text{C}$	$R_{IO}$	$>10^{12}$	$\Omega$
	$V_{IO} = 500\text{V}$ , $100^\circ\text{C} \leq T_{amb} \leq 125^\circ\text{C}$	$R_{IO}$	$>10^{11}$	$\Omega$
	$V_{IO} = 500\text{V}$ , $T_{amb}=T_s$	$R_{IO}$	$>10^9$	$\Omega$
Isolation capacitance	$f = 1\text{MHz}$	$C_{IO}$	~4	pF
Safety total power dissipation	$\theta_{JA} = 59.2\text{ }^\circ\text{C/W}$ , $V_I = 5.25\text{V}$ , $T_J = 150\text{ }^\circ\text{C}$ , $T_A = 25\text{ }^\circ\text{C}$	$P_s$	2111	mW
Safety input, output, or supply current	$\theta_{JA} = 59.2\text{ }^\circ\text{C/W}$ , $V_I = 5.25\text{ V}$ , $T_J = 150\text{ }^\circ\text{C}$ , $T_A = 25\text{ }^\circ\text{C}$	$I_s$	402	mA
Maximum safety temperature		$T_s$	150	$^\circ\text{C}$
<b>UL1577</b>				
Insulation voltage per UL	$V_{TEST} = V_{ISO}$ , $t = 60\text{ s}$ (qualification), $V_{TEST} = 1.2 \times V_{ISO}$ , $t = 1\text{ s}$ (100% production test)	$V_{ISO}$	5000	$V_{RMS}$

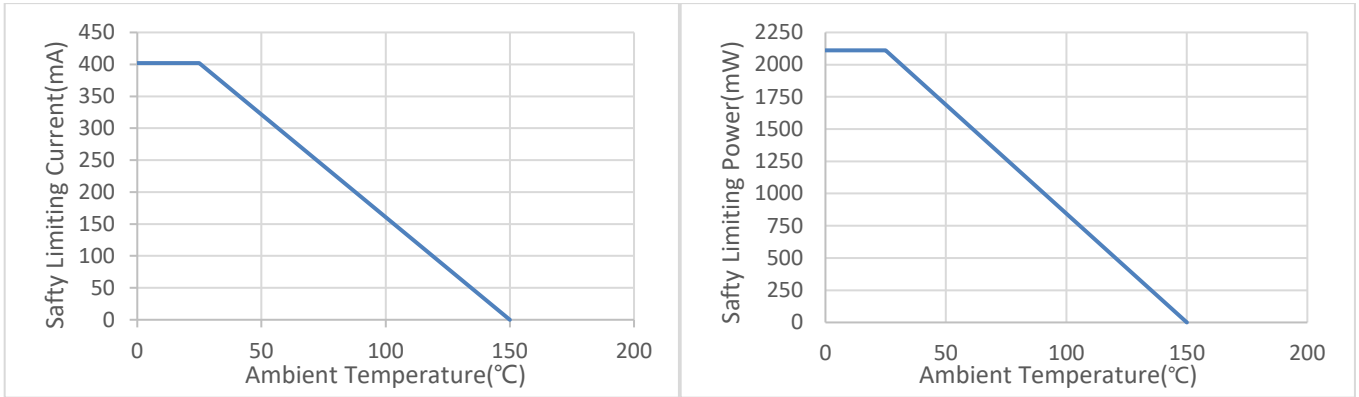

Figure 7.1 NSIP954x Thermal Derating Curve, Dependence of Safety Limiting Values with Case Temperature per DIN VDE V 0884-17

### 7.3. Regulatory Information

The NSIP954x-Q1 are certified with UL1577, VDE0884-17, GB4943.1, EN IEC 62368-1.

<b>UL1577 &amp; CSA Component Acceptance</b>		<b>DIN EN IEC 60747-17</b>		<b>EN IEC62368-1</b>	<b>GB4943.1</b>
<b>Notice 5A</b>		<b>(VDE 0884-17)</b>			
Single Protection, 5000V <sub>rms</sub> Isolation voltage	Single Protection, 5000V <sub>rms</sub> Isolation voltage	Reinforced Insulation V <sub>IORM</sub> =1500Vpeak V <sub>IOTM</sub> =7070Vpeak	5000Vrms for 1min		Certified according to GB4943.1
Certified by UL		Certified by TUV			Certified by CQC
E500602	E500602	R50632560 0002	R50574061		CQC20001264939

## 8. Function Description

### 8.1. Overview

The NSIP954x devices are quad-channel digital isolators with integrated isolated DC-DC converter. The digital isolators are based on Novosense capacity isolation barrier technique. The isolated DC-DC converter provides up to 500mW output power using on chip transformer. The feedback PWM signal is sent to primary side by a digital isolator based on capacity isolation technology. The NSIP954x devices are safety certified by UL1577, supporting 5kVrms insulation withstand voltage, while providing high electromagnetic immunity and low emissions. The data rate of the NSIP954x is up to 150Mbps, and the common-mode transient immunity (CMTI) is up to 100kV/us.

The high integrated solution can help to simplify system design and improve reliability. The NSIP954x devices are suitable for the limited PCB space applications. The devices are also suitable for wide temperature application which the most the power module can not support.

### 8.2. Device Functional Modes

The NSIP954x devices provide 5V to 5V, 5V to 3.3V, 3.3V to 3.3V conversion mode, the output voltage can be set by SEL pin. Supply configuration table showed below.

<i>SEL PIN</i>	<i>VDD</i>	<i>VISO</i>
Shorted to VISO	5V	5V
Shorted to GND2 or floating	5V	3.3V
Shorted to GND2 or floating	3.3V	3.3V

The NSIP954x devices provide four channel digital isolators. The digital isolators have default weak pull up or pull down input status when input is floating as shown in below table.

<i>Input</i>	<i>VDD status</i>	<i>VISO status</i>	<i>Output</i>	<i>Comment</i>
H	Ready	Ready	H	Normal operation
L	Ready	Ready	L	
floating	Ready	Ready	L(NSIP954xW0) H(NSIP954xW1)	Floating input status

### 8.3. Output Short And Over Temperature Protection

The NSIP954x devices are protected against output short. When the devices detect the output is short, the device will be in Hiccup mode and the transfer power will be limited. So the temperature of the device will be low, and the device is protected.

The NSIP954x devices are also protected against over temperature. When the devices detect the chip is over 165°C, the device will be shut down until the temperature of the device is below 145°C.

## 9. Application Note

### 9.1. Typical Application

The NSIP954x requires 0.1  $\mu\text{F}$  and 10 $\mu\text{F}$  bypass capacitors between VDD and GND1, VISO and GND2. The capacitors should be placed as close as possible to the package. This is very important for the performance of the device.

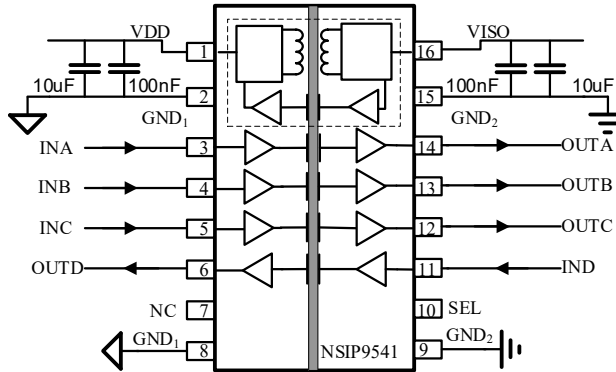

Figure 9.1 Basic schematic of NSIP954x

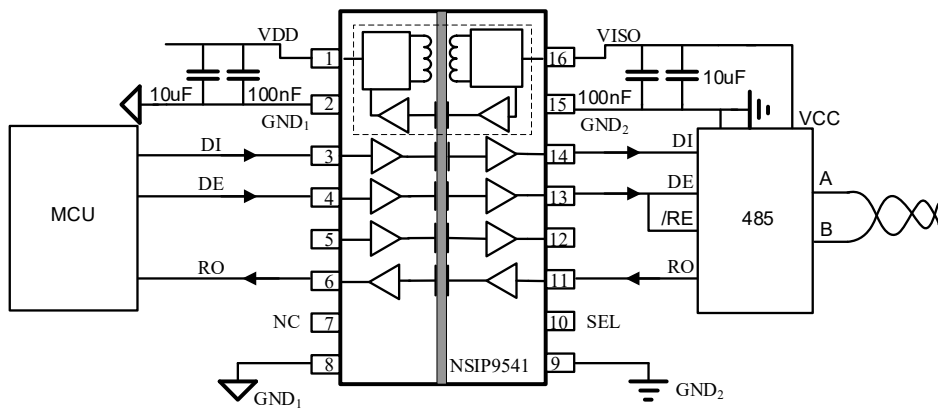

Figure 9.2 Half-Duplex RS-485 schematic using NSIP954x

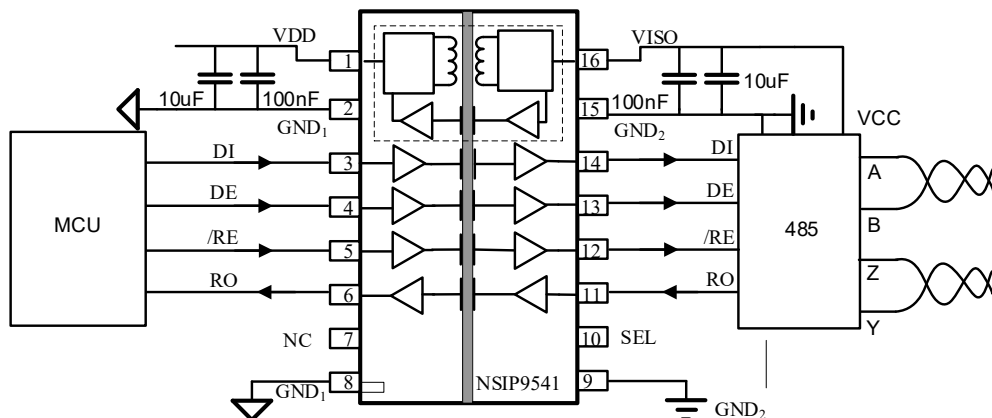

Figure 9.3 full-Duplex RS-485 schematic using NSIP954x

### 9.2. PCB Layout

The recommended PCB layout is shown below. The low ESR capacitor C1 should be closed to PIN1 and PIN2, the distance should be less than 1mm. The low ESR capacitor C3 should be closed to PIN15 and PIN16, the distance should be less than 1mm. It is recommended that C1=C3=100nF and C2=C4=10uF.

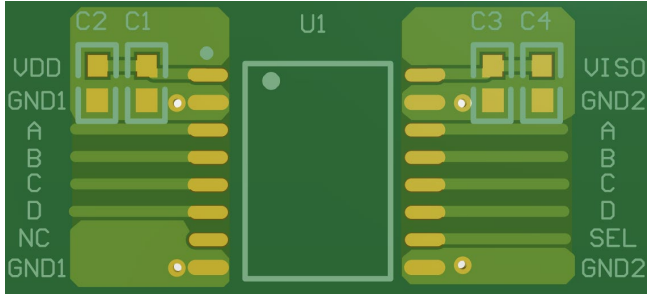

Figure 9.4 Recommended PCB Layout — Top Layer

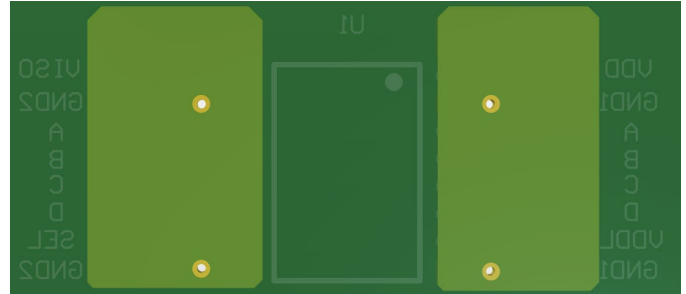

Figure 9.5 Recommended PCB Layout — Bottom Layer

## 10. Package Information

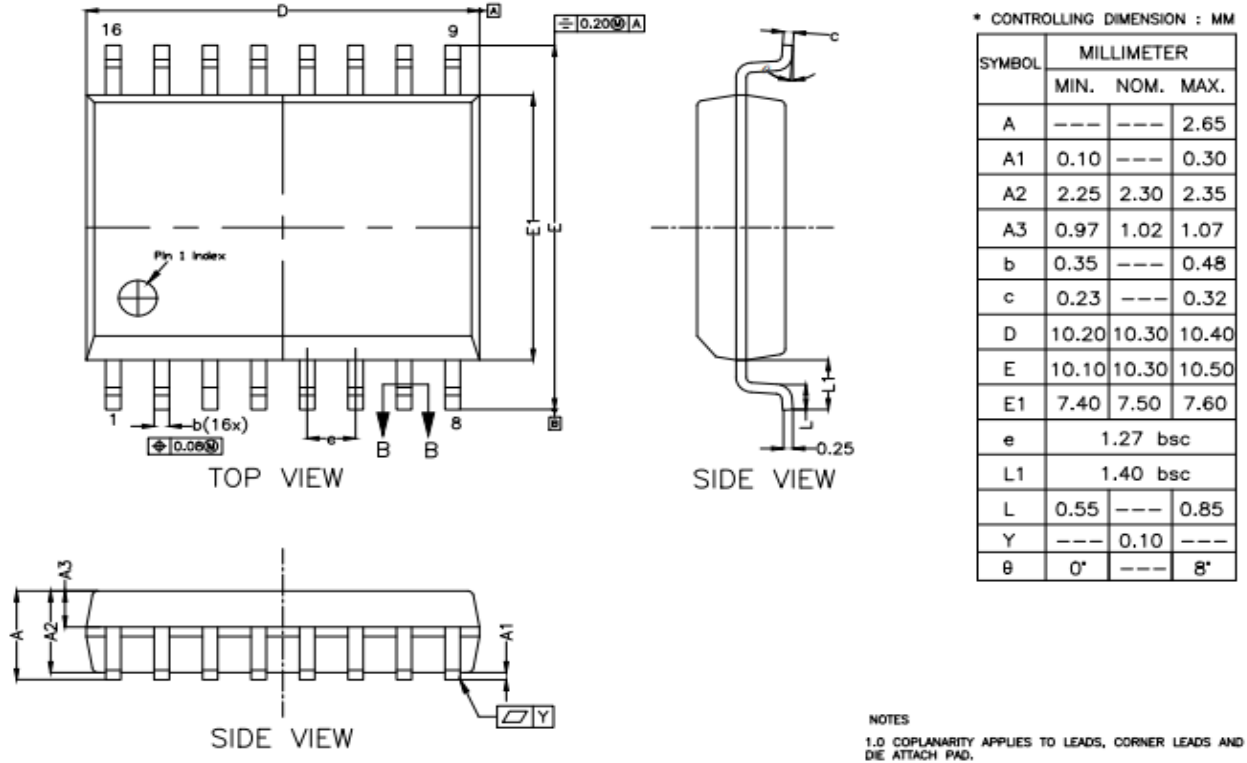
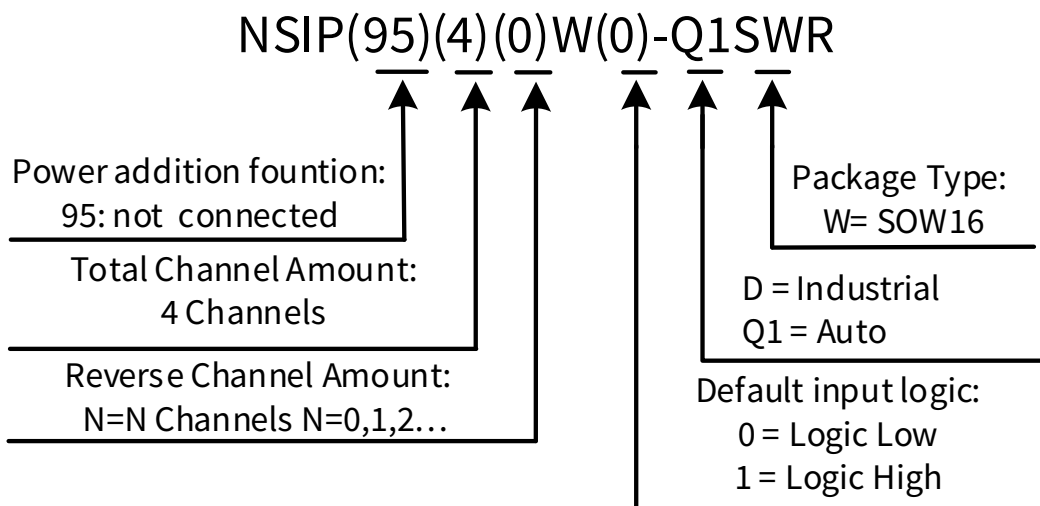

Figure 10.1 SOW16 Package Shape and Dimension in millimeters

### 11. Order Information

Part Number	Isolation Rating (kV)	Number of side 1 inputs	Number of side 2 inputs	Max Data Rate (Mbps)	Default output logic	Temperature	MSL	Package Type	Package Drawing	SPQ
NSIP9540W0-Q1SWR	5	4	0	150	Low	-40 to 125°C	3	SOP16 (300mil)	SOW16	1500
NSIP9540W1-Q1SWR	5	4	0	150	High	-40 to 125°C	3	SOP16 (300mil)	SOW16	1500
NSIP9541W0-Q1SWR	5	3	1	150	Low	-40 to 125°C	3	SOP16 (300mil)	SOW16	1500
NSIP9541W1-Q1SWR	5	3	1	150	High	-40 to 125°C	3	SOP16 (300mil)	SOW16	1500
NSIP9542W0-Q1SWR	5	2	2	150	Low	-40 to 125°C	3	SOP16 (300mil)	SOW16	1500
NSIP9542W1-Q1SWR	5	2	2	150	High	-40 to 125°C	3	SOP16 (300mil)	SOW16	1500
NSIP9543W0-Q1SWR	5	1	3	150	Low	-40 to 125°C	3	SOP16 (300mil)	SOW16	1500
NSIP9543W1-Q1SWR	5	1	3	150	High	-40 to 125°C	3	SOP16 (300mil)	SOW16	1500
NSIP9544W0-Q1SWR	5	0	4	150	Low	-40 to 125°C	3	SOP16 (300mil)	SOW16	1500
NSIP9544W1-Q1SWR	5	0	4	150	High	-40 to 125°C	3	SOP16 (300mil)	SOW16	1500

Part Number Rule:



## 12. Documentation Support

<i>Part Number</i>	<i>Product Folder</i>	<i>Datasheet</i>	<i>Technical Documents</i>	<i>Isolator selection guide</i>
NSIP954x	<a href="#">Click here</a>	<a href="#">Click here</a>	<a href="#">Click here</a>	<a href="#">Click here</a>

### 13. Tape And Reel Information

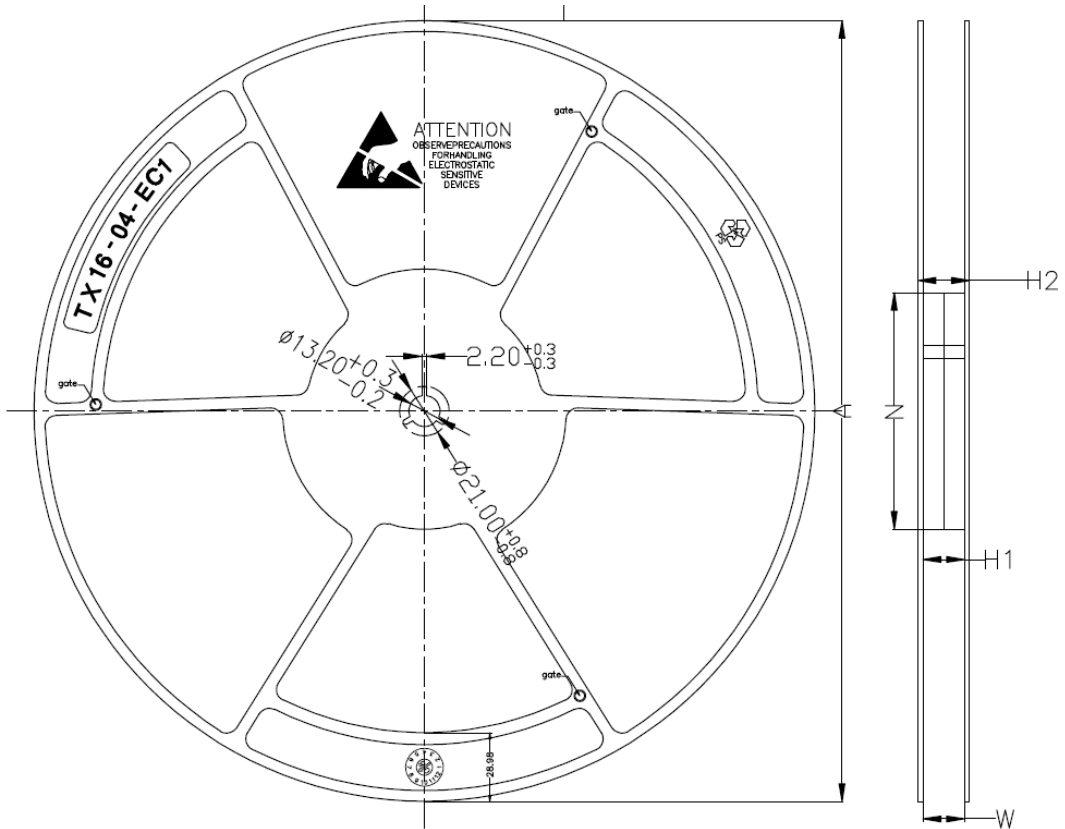

PRODUCT SPECIFICATIONS					
TAPE WIDTH	$\phi A \begin{smallmatrix} +2 \\ -2 \end{smallmatrix}$	$\phi N \begin{smallmatrix} +2 \\ -2 \end{smallmatrix}$	$H1 \begin{smallmatrix} +2 \\ -0 \end{smallmatrix}$	$H2 \begin{smallmatrix} +1 \\ -1 \end{smallmatrix}$	$W \begin{smallmatrix} +3.5 \\ -0.2 \end{smallmatrix}$
16MM	330	100	16.4	20.6	16.4

- NOTES:**
1. MATERIAL: DISSIPATIVE (BLACK)
  2. FLANGE WARPAGE: 3 MM MAXIMUM
  3. ALL DIMENSIONS ARE IN MM
  4. ESD - SURFACE RESISTIVITY: 10 TO 10 OHMS/SQ
  5. GENERAL TOLERANCE:  $\pm 0.25$  MM

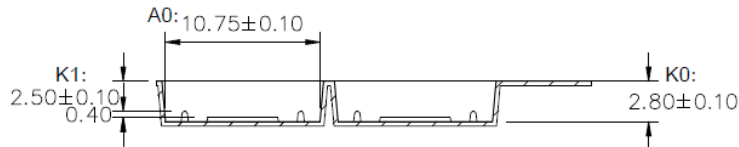
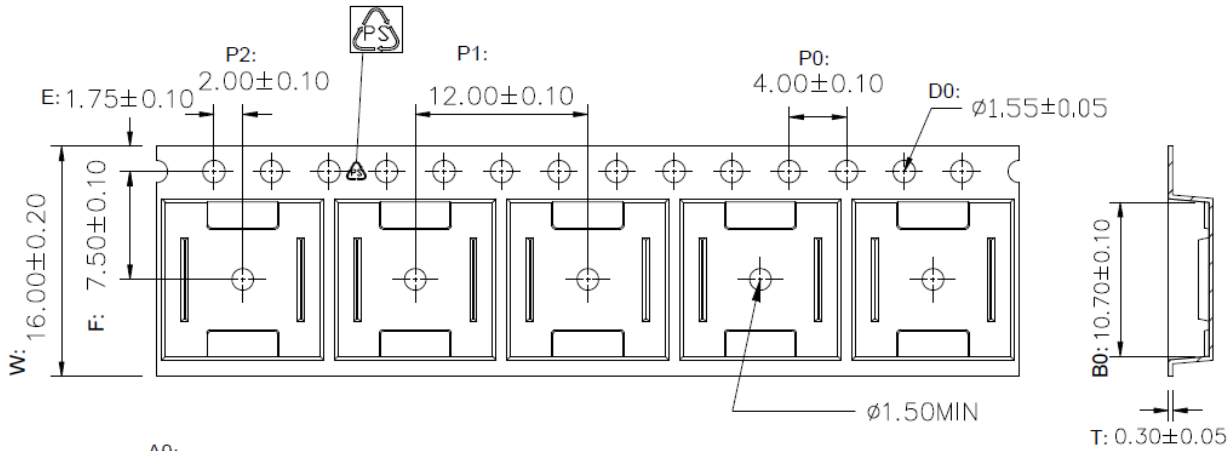

1. 10 sprocket hole pitch cumulative tolerance  $\pm 0.20$  .
2. Carrier camber is within 1 mm in 250 mm.
3. Material : Black Conductive Polystyrene Alloy .
4. All dimensions meet EIA-481 requirements.
5. Thickness :  $0.30 \pm 0.05$ mm.
6. Packing length per 22" reel : 378 Meters.(復巻 N=122)
7. Component load per 13" reel : 1000 pcs.
8. Surface resistivity :  $10^5 \sim 10^{10} \Omega/\square$

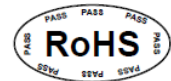

W	16.00±0.20
A0	10.75±0.10
B0	10.70±0.10
K0	2.80±0.10
K1	2.50±0.10

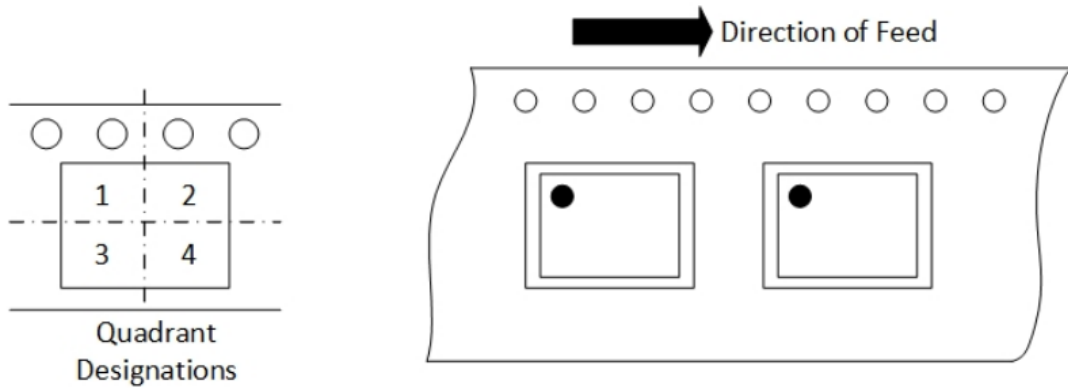

Figure 13.1 Tape and Reel Information of SOW16

## 14. Revision History

Revision	Description	Date
1.0	Initial version	2025/10/21

## **IMPORTANT NOTICE**

The information given in this document (the “Document”) shall in no event be regarded as any warranty or authorization of, express or implied, including but not limited to accuracy, completeness, merchantability, fitness for a particular purpose or infringement of any third party’s intellectual property rights.

Users of this Document shall be solely responsible for the use of NOVOSENSE’s products and applications, and for the safety thereof. Users shall comply with all laws, regulations and requirements related to NOVOSENSE’s products and applications, although information or support related to any application may still be provided by NOVOSENSE.

This Document is provided on an “AS IS” basis, and is intended only for skilled developers designing with NOVOSENSE’s products. NOVOSENSE reserves the rights to make corrections, modifications, enhancements, improvements or other changes to the products and services provided without notice. NOVOSENSE authorizes users to use this Document exclusively for the development of relevant applications or systems designed to integrate NOVOSENSE’s products. No license to any intellectual property rights of NOVOSENSE is granted by implication or otherwise. Using this Document for any other purpose, or any unauthorized reproduction or display of this Document is strictly prohibited. In no event shall NOVOSENSE be liable for any claims, damages, costs, losses or liabilities arising out of or in connection with this Document or the use of this Document.

For further information on applications, products and technologies, please contact NOVOSENSE ([www.novosns.com](http://www.novosns.com)).

**Suzhou NOVOSENSE Microelectronics Co., Ltd**