

NSIP6051 Transformer Driver for Isolated Power Supplies

Datasheet (EN) 1.1

Product Overview

The NSIP6051 is a push-pull transformer driver specially designed for small size, low-power isolation power supply with low standby power consumption. Its periphery only needs to match simple input and output filter capacitors, isolation transformer and rectifier circuits. Its internal integrated oscillator provides a pair of high-precision complementary signals to drive two N-channel MOSFETs. The internal design of the chip follows a symmetrical structure, which can effectively ensure the high symmetry of the two power MOSFETs and avoid magnetic bias during the working process of the circuit. Ultra-low noise and EMI are achieved by slew rate control of the output switch voltage and through Spread Spectrum Clocking (SSC). The internal protection features include over current protection, under-voltage lockout, thermal shutdown and break-before-make circuitry. The NSIP6051 is available in a small SOT-23 (5) package, and is specified for operation at temperatures from -40°C to 125°C .

Key Features

- Push-pull driver for transformers
- Support 2.25V to 5.5V supply
- Ultra-low EMI
- Over-current protection (OCP)
- Over temperature protection
- Spread spectrum clocking
- Slew-rate control
- Small 5-pin SOT-23 package

Applications

- Isolated interface power supply for I2C, CAN,
- RS-485, RS-422, RS-232, SPI, Low-Power LAN
- Industrial automation
- Medical equipment
- Process control
- IGBT gate drive power supply

Device Information

Part Number	Package	Body Size
NSIP6051-DSTAR	SOT23- 5L	2.90 mm x 1.60 mm

Functional Block Diagrams

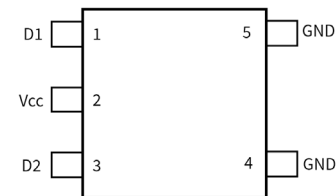

Figure 1. NSIP6051

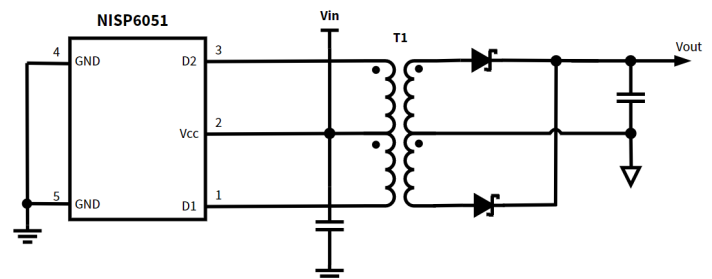

Figure 2. Simplified Schematic

INDEX

1. PIN CONFIGURATION AND FUNCTIONS	3
2. ABSOLUTE MAXIMUM RATINGS	3
3. ESD RATINGS	3
4. RECOMMENDED OPERATING CONDITIONS	4
5. THERMAL INFORMATION	4
6. ELECTRICAL CHARACTERISTICS	5
7. SWITCHING CHARACTERISTICS	5
8. TYPICAL CHARACTERISTICS	8
9. PARAMETER MEASUREMENT INFORMATION	10
10. DETAILED DESCRIPTION	11
10.1 OVERVIEW	11
10.2 FEATURE DESCRIPTION	11
11. APPLICATION AND IMPLEMENTATION	13
11.1 TYPICAL APPLICATION	13
11.2 DESIGN REQUIREMENTS	13
11.2.1 DETAILED DESIGN REQUIREMENTS	13
11.2.1.1 LDO SELECTION	13
11.2.1.2 DIODE SELECTION	13
11.2.1.3 CAPACITOR CONFIGURATION	14
11.2.1.4 TRANSFORMER SELECTION	14
11.2.1.4.1 V-T PRODUCT CALCULATION	14
11.2.1.4.2 TURNS RATION ESTIMATE	14
11.2.1.4.3 RECOMMENDED TRANSFORMER CONFIGURATION SOLUTION	15
12. LAYOUT	16
12.1 LAYOUT GUIDELINES	16
12.2 LAYOUT EXAMPLE	16
13. PACKAGE INFORMATION	17
14. ORDER INFORMATION	17
15. DOCUMENTATION SUPPORT	17
16. TAPE AND REEL INFORMATION	18
17. REVISION HISTORY	19

1. Pin Configuration and Functions

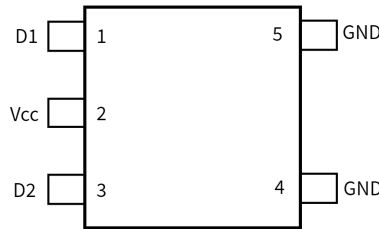

Figure 1.1 NSIP6051

Table 1.1 Pin Functions

PIN NO.	SYMBOL	FUNCTION
1	D1	Open Drain output 1. Connect to transformer primary side 1.
2	VCC	Power supply. Connect a 0.1μF and a 10μF low ESR capacitor. The interval time between two power-on of VCC must be greater than 30μs.
3	D2	Open Drain output 2. Connect to transformer primary side 2.
4,5	GND	Device ground. Connect this pin to board ground.

2. Absolute Maximum Ratings

Parameters	Symbol	Min	Typ	Max	Unit	Comments
Power Supply Voltage	V _{CC}	-0.3		6	V	
Output switch voltage	V _{D1} , V _{D2}			16	V	
Junction temperature	T _J	-40		150	°C	
Operating Temperature	T _{opr}	-40		125	°C	
Storage Temperature	T _{stg}	-65		150	°C	

3. ESD Ratings

Parameters	Symbol	Min	Typ	Max	Unit	Comments
Electrostatic discharge	HBM	-8000		+8000	V	
	CDM	-2000		+2000	V	

4. Recommended Operating Conditions

Parameters	Symbol	min	typ	max	unit	Comments
Supply voltage	V_{CC}	2.25		5.5	V	
Output switch voltage	V_{D1}, V_{D2}			12	V	
D1 and D2 output switch current – Primary-side	I_{D1}, I_{D2}			350	mA	$V_{CC} = 5\text{ V} \pm 10\%$ $V_{CC} = 3.3\text{ V} \pm 10\%$
Ambient Temperature	T_a	-40		125	°C	

5. Thermal Information

Parameters	Symbol	SOT23-5	Unit
IC Junction-to-air thermal resistance	θ_{JA}	162.5	°C/W
Junction-to-board thermal resistance	θ_{JB}	56.2	°C/W
Junction-to-case (top) thermal resistance	θ_{JCtop}	96.2	°C/W
Junction-to-top characterization parameter	Ψ_{JT}	35	°C/W
Junction-to-board characterization parameter	Ψ_{JB}	55	°C/W

6. Electrical Characteristics

Over full range of recommended operating conditions, unless otherwise noted. All typical value is at $T_A = 25^\circ\text{C}$, $V_{CC} = 5\text{ V}$.

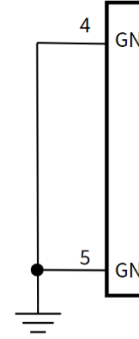
Parameters	Symbol	Min	Typ	Max	Unit	Comments
Switch-on resistance	R_{ON}		0.74	1.5	Ω	$V_{CC} = 3.3\text{ V} \pm 10\%$,
			0.59	1.27	Ω	$V_{CC} = 5\text{ V} \pm 10\%$,
Average supply current	I_{CC}		0.87	1.1	mA	$V_{CC} = 3.3\text{ V} \pm 10\%$, no load
			1	1.2		$V_{CC} = 5\text{ V} \pm 10\%$, no load
D1, D2 Average switching frequency	f_{SW}	315	425	530	kHz	<p>$V_{CC} = 5\text{ V} \pm 10\%$, $V_{CC} = 3.3\text{ V} \pm 10\%$</p>  <p>See Figure 9.1</p>
Spread Spectrum Clocking			$\pm 5.5\%$			
Positive UVLO threshold	V_{CC+} (UVLO)			2.25	V	
Negative UVLO threshold	V_{CC-} (UVLO)	1.7			V	
UVLO threshold hysteresis	V_{HYS} (UVLO)		0.3		V	
Protection current threshold		0.35	0.67	0.99	A	
Current limit			0.38	0.55	A	
THERMAL SHUT DOWN						
T_{SD} turn on temperature	T_{SD+}	152	169	180	$^\circ\text{C}$	
T_{SD} turn off temperature	T_{SD-}	130	150	166	$^\circ\text{C}$	
T_{SD} hysteresis	T_{SD-}	13	19		$^\circ\text{C}$	

7. Switching Characteristics

Over full range of recommended operating conditions, unless otherwise noted.

Parameters	Symbol	Min	Typ	Max	Unit	Comments
------------	--------	-----	-----	-----	------	----------

D1, D2 output rise time	t_{r-D}	78	ns	$V_{CC} = 3.3 \text{ V} \pm 10\%$, See NSIP6051 <p>Figure 9.1</p>
		91	ns	$V_{CC} = 5 \text{ V} \pm 10\%$, See NSIP6051 <p>Figure 9.1</p>
D1, D2 output fall time	t_{f-D}	54	ns	$V_{CC} = 3.3 \text{ V} \pm 10\%$, See NSIP6051 <p>Figure 9.1</p>
		60	ns	$V_{CC} = 5 \text{ V} \pm 10\%$, See NSIP6051 <p>Figure 9.1</p>

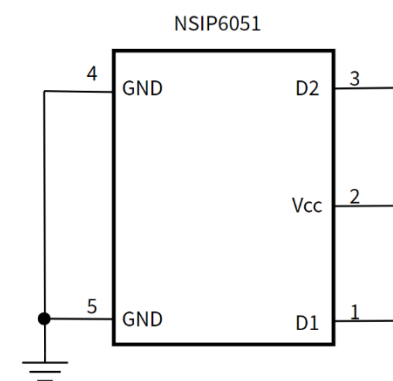
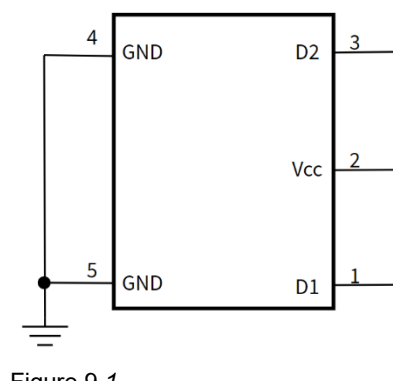
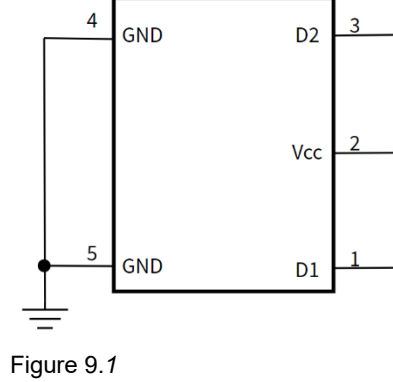
					 <p>NSIP6051</p> <p>Figure 9.1</p>
Break-before-make time	t_{BBM}		150	ns	<p>$V_{CC} = 3.3\text{ V} \pm 10\%$, See NSIP6051</p>  <p>NSIP6051</p> <p>Figure 9.1</p>
			150	ns	<p>$V_{CC} = 5\text{ V} \pm 10\%$, See NSIP6051</p>  <p>NSIP6051</p> <p>Figure 9.1</p>

8. Typical Characteristics

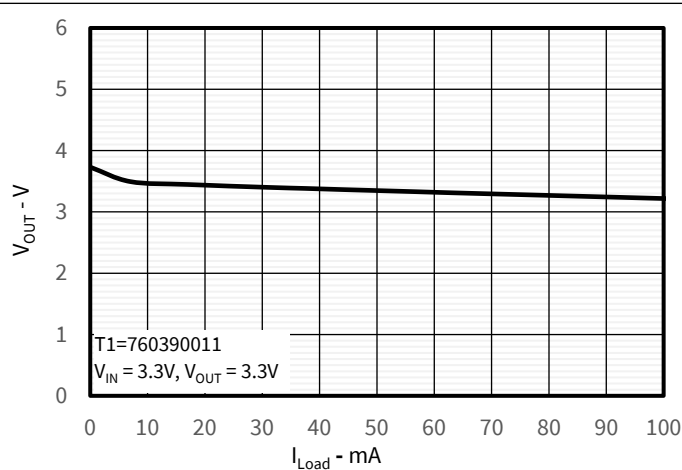

Figure 8.1 Output Voltage vs Load Current

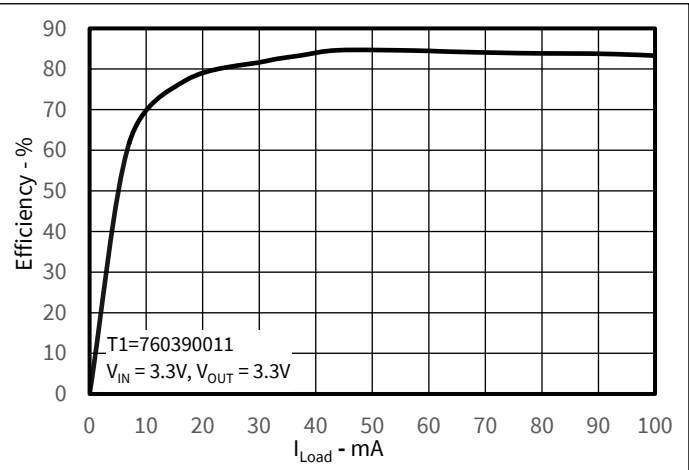

Figure 8.2 Efficiency vs Load Current

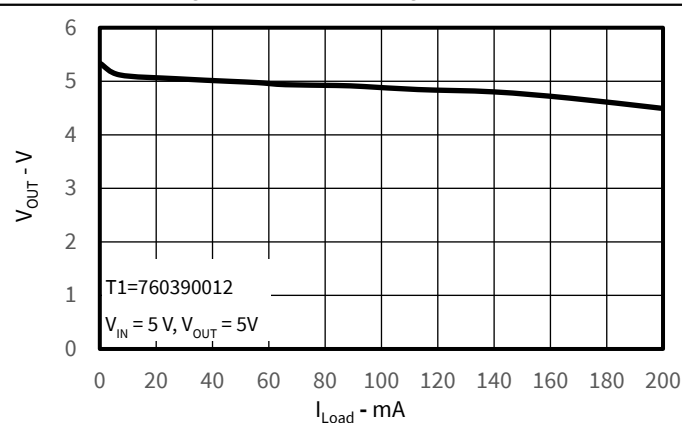

Figure 8.3 Output Voltage vs Load Current

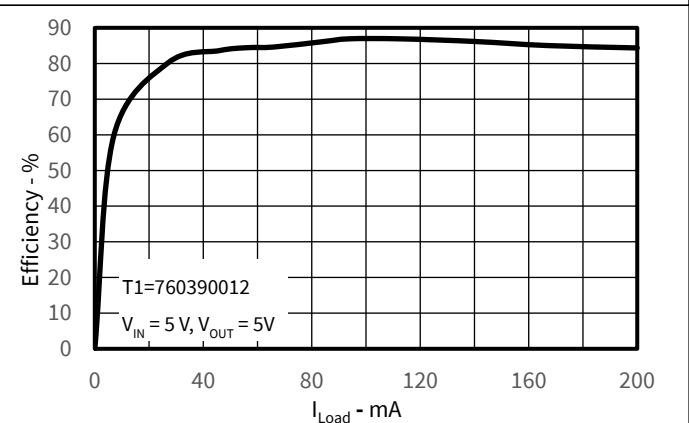

Figure 8.4 Efficiency vs Load Current

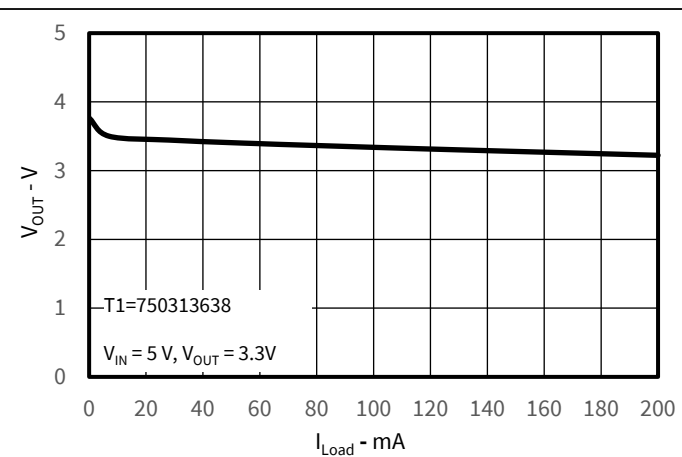

Figure 8.5 Output Voltage vs Load Current

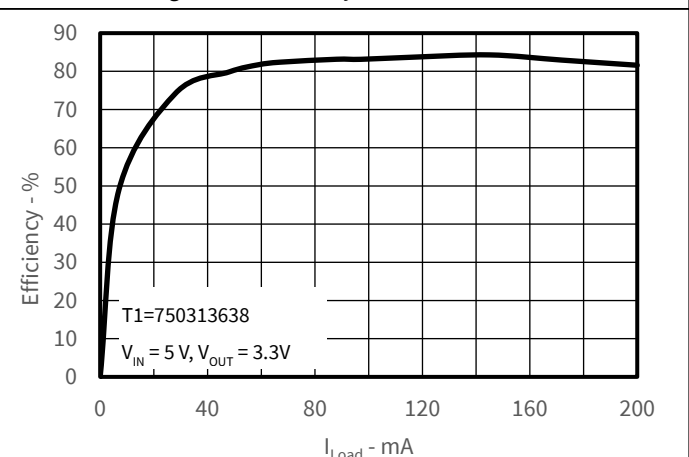

Figure 8.6 Efficiency vs Load Current

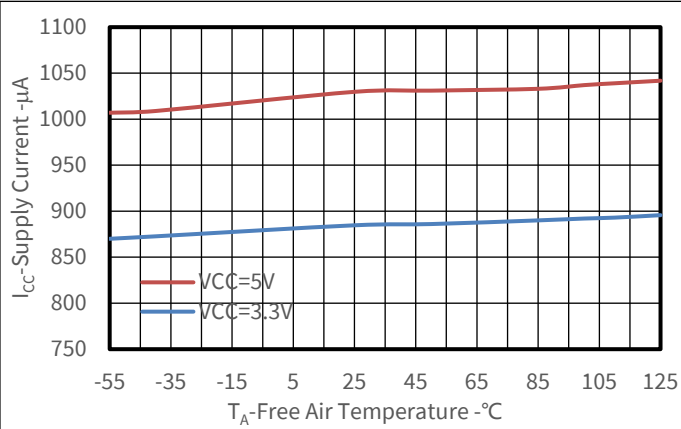

Figure 8.7 Average Supply Current vs Free-Air Temperature

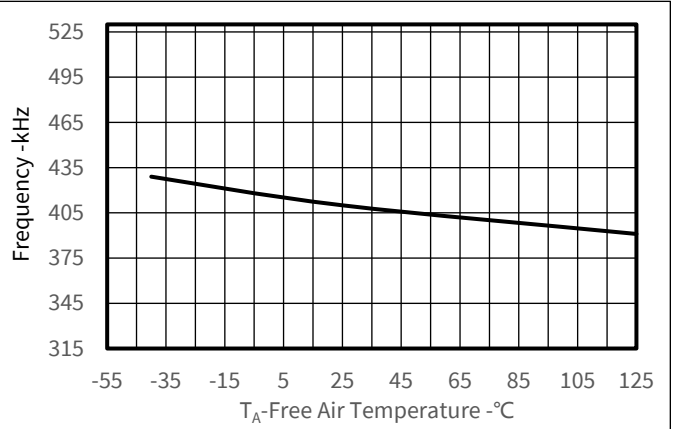

Figure 8.8 Average Frequency vs Free-Air Temperature

9. Parameter Measurement Information

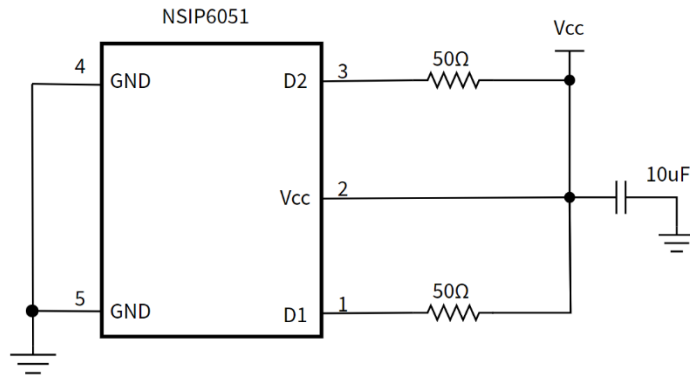

Figure 9.1 Test Circuit for FSW, T_{r-D} , F_{t-D} , T_{BBM}

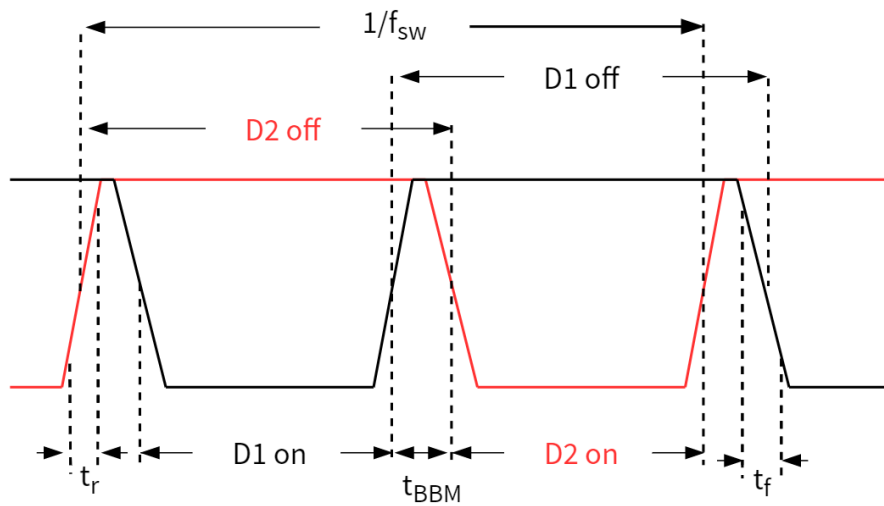

Figure 9.2 Timing Diagram

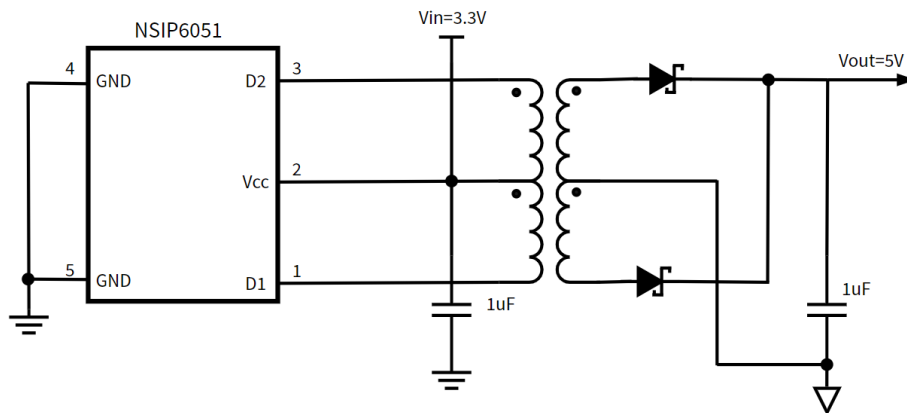

Figure 9.3 Measurement Circuit for Unregulated Output

10. Detailed Description

10.1 Overview

The NSIP6051 is transformer driver designed for low cost, small size, isolated DC-DC converters in push-pull topologies. The device consists of an oscillator and a gate driver. The output frequency of the oscillator is divided by frequency divider, which provides two complementary output signals with a duty cycle of 50%, and a dead time t_{BBM} is designed between the two drives to avoid D1 and D2 conduction at the same time.

In order to improve EMI performance, the NSIP6051 oscillator has added spread spectrum clocking function. NSIP6051 integrates a thermal shutdown module and a current clamping function when the current is too large, to ensure that the chip itself works in the safety zone.

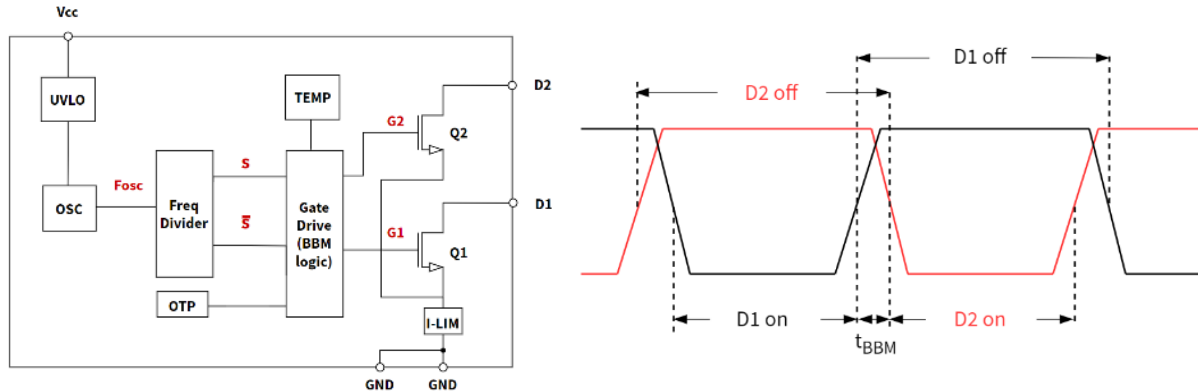

Figure 10.1 Functional Block Diagram and Output Timing with Break-Before-Make Action

10.2 Feature Description

10.2.1 Push-Pull Converter

Push-pull converters require transformers with center-taps to transfer power from the primary to the secondary.

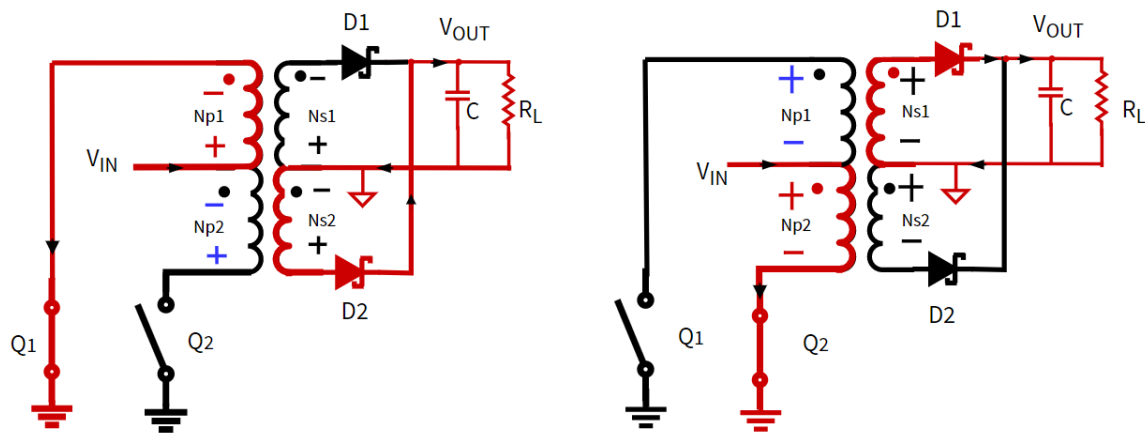

Figure 10.2 Switching Cycles of a Push-Pull Converter

The equivalent schematic diagram of the working process of a push-pull converter is shown in Figure 10.2. Switches Q1 and Q2 work in turns, with a duty cycle of nearly 50%. When Q1 is turned on, the input power flows from the input port V_{IN} to the eponymous end of the transformer primary winding N_{p1} , and from the synonymous end of N_{p1} to switch Q1 to GND. At the same time, the energy is transferred to the secondary side through the transformer. The output current flows out from the eponymous end of the secondary winding N_{s2} , transmits it to the output V_{OUT} through the rectifier diode D2, and finally returns to the synonymous end of N_{s2} from the output GND after passing through the load. The working process of switch Q2 is basically the same as that of Q1.

When the circuit is working, each winding of the transformer (N_{p1} , N_{p2} , N_{s1} , N_{s2}) will generate a corresponding induced voltage. The amplitude of the induced voltage is proportional to the ratio of turns of the transformer winding. The voltage stress of Q1 and Q2 during the operation of the push-pull converter is $2 \times V_{in}$ voltage.

Start-Up Mode

When the voltage at the V_{CC} ramps up to 2.25V, the internal oscillator starts to work. The output stage starts to switch, and the drain signal amplitude of D1 and D2 has not reached the maximum value.

Current Limit

The NSIP6051 device performs current limiting by clamping the output current. When the output current increases to the threshold current, the output gate drive voltage clamp. The device has a current limiting function that can help isolate the overcurrent of the power transformer, but overheating losses need to be considered and may lead to overheating protection.

Over Temperature Protection

The NSIP6051 device supports overtemperature protection. When the junction temperature of the device is higher than the protection temperature threshold, at which the device will turn off output to protect the device from overheating damage. When the junction temperature is lower than the descending threshold, the device will resume startup.

Spread Spectrum

Radiation emission is an important concern in high current switching power supplies. NSIP6051 has the ability to modulate its internal clock, distributing transmission energy over a wider frequency band rather than a narrow peak, greatly improving EMI performance through its spread spectrum feature.

11. Application and Implementation

Note

The information contained in the following application section is not part of the NOVOSENSE component specification and NOVOSENSE does not guarantee its accuracy or completeness. NOVOSENSE's customers are responsible for determining whether components are suitable for their purpose, as well as validating and testing their design implementations to confirm system functionality.

11.1 Typical Application

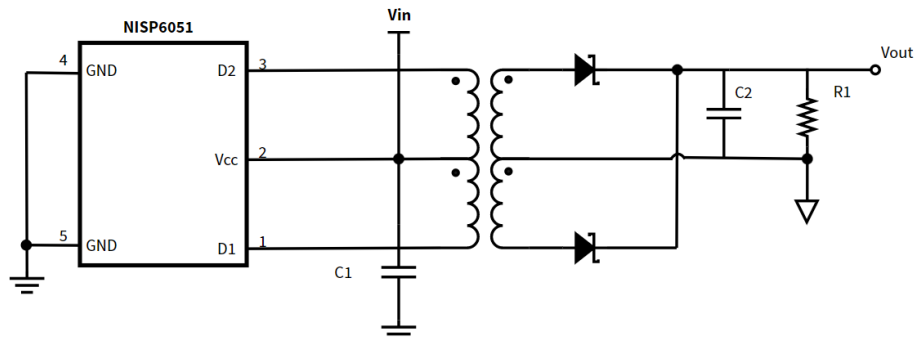

Figure 11.1 Typical Application Schematic

11.2 Design Requirements

For this design example, use the parameters listed in Table 11-1 as design parameters.

Table 11-1. Design Parameters

DESIGN PARAMETER	EXAMPLE VALUE
Input voltage range	3.3 V ± 10%
Output full load	5 V
Maximum load current	100 mA

11.2.1 Detailed Design Requirements

The following sections focus on the design of efficient push-pull conversions with high current drive capability.

11.2.1.1 LDO Selection

The minimum requirements for LDO: Note the following points:

- For a load current of 100 mA, it is recommended to choose a continuous output current capacity of 100 mA to 150 mA, slightly exceeding the specified load current.
- The output voltage of the isolated power supply should be greater than the output voltage of the LDO for proper operation of the LDO. Therefore, it is advisable to choose a LDO chip with the smallest possible dropout voltage.

$$V_{I-min} = V_{DO-max} + V_{O-max} \tag{1}$$

Note that the output voltage of the push-pull rectifier at the specified load current is equal to or higher V_{I-min} . Otherwise, the LDO will lose any line regulation.

- The maximum input voltage of the LDO must be higher than the rectified output at no-load. At this point, the secondary reaches its maximum voltage.

$$V_{S-max} = V_{IN-max} \times n \tag{2}$$

V_{IN-max} is the maximum input voltage of the converter, and n is the ratio of turns of the transformer. Therefore, in order to prevent LDO damage, the maximum LDO input voltage must be higher than V_{S-max} .

11.2.1.2 Diode Selection

The selection of Schottky diodes needs to consider the following two points:

- Selecting a diode for the power supply, it is recommended to choose a low forward voltage and fast recovery diode. A low forward voltage helps improve the output efficiency of the power supply. For a low-cost option, the MBR0520L Schottky rectifier diode is recommend, with a typical forward voltage of 275mV and forward current of 100mA. However, if operating at ambient temperatures higher than 100°C, it is advisable to use the RB168M-40 diode.
- Considering the impact of temperature on forward voltage, it is advisable to select a rectifier with a low forward voltage drop, especially at low temperatures.

11.2.1.3 Capacitor Configuration

- In the design process, capacitors of 0.1µF and 10µF need to be placed in parallel between the input pin of the center-tap transformer and the device V_{cc} pin, to achieve the minimum line path and reduce the inductance of the wiring.
- To ensure low-inductance paths use two vias in parallel for each connection. The secondary rectifier output and the LDO output must be placed in parallel with 10µF and 0.1µF capacitors. It improves the stability of the power supply and reduce the output ripple.
- A low- ESR ceramic capacitor will meet circuit requirements.

11.2.1.4 Transformer Selection

11.2.1.4.1 V-t Product Calculation

Transformer selection needs to consider the Vt factor. the purpose is to prevent transformer saturation. The V_{tmin} is calculated by the maximum input voltage multiplying 50% of the maximum cycle time.

$$V_{t_{min}} \geq V_{IN-max} \times \frac{T_{max}}{2} = \frac{V_{IN-max}}{2 \times f_{min}} \tag{3}$$

Take the values from the data sheet into Equation 3 yields:

$$V_{t_{min}} \geq \frac{3.6V}{2 \times 315kHz} = 5.7V\mu s \quad \text{for 3.3V}$$

$$V_{t_{min}} \geq \frac{5.5V}{2 \times 315kHz} = 8.7V\mu s \quad \text{for 5V applications} \tag{4}$$

Other important factors such as isolation voltage, transformer power and turns ratio must be considered before the final selection decision is made.

11.2.1.4.2 Turns Ration Estimate

Assumed the rectifier diode and linear regulator have been selected, and the V-t product of the selected transformer is not less than 8.7Vµs. The minimum turns ratio that allows the push-pull converter to operate perfectly over a specified current and temperature range needs to be determined.

From the LDO selection section. The V_{S-min} must be large enough to allow the maximum voltage to drop V_{F-max} to cross the rectifier diode and still provide enough input voltage to the regulator to maintain voltage stability.

$$V_{S-min} = V_{F-max} + V_{D0-max} + V_{O-max} \tag{5}$$

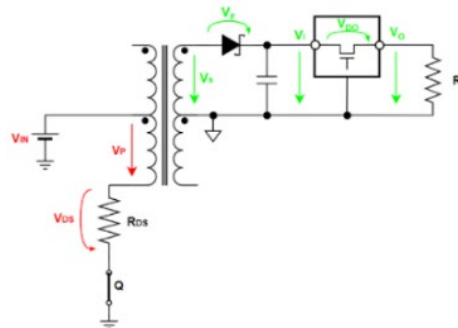

Figure 11.2 Establishing the Required Minimum Turns Ratio Through $N_{min} = 1.031 \times V_{s-min}/V_{p-min}$

The minimum available primary voltage VP-min is calculated. Drain-source voltage of the NSIP6051 is VDS-max. The minimum converter input voltage is VIN-min:

$$V_{P-min} = V_{IN-min} - V_{DS-max} \tag{6}$$

V_{DS-max} is the product of the maximum R_{DS(on)} and I_D values for a given supply specified in the NSIP6051 data sheet:

$$V_{DS-max} = R_{DS-max} \times I_{Dmax} \tag{7}$$

Then inserting Equation 7 into Equation 6 yields:

$$V_{P-min} = V_{IN-min} - R_{DS-max} \times I_{Dmax} \tag{8}$$

Inserting Equation 8 and Equation 5 into Equation 9 provides the minimum turns ration with:

$$n_{min} = 1.031 \times \frac{V_{F-max} + V_{DO-max} + V_{O-max}}{V_{IN-min} - R_{DS-max} \times I_{D-max}} \tag{9}$$

Example:

For a 3.3 V_{IN} to 5 V_{OUT} converter using the rectifier diode MBR0520 and the LDO TPS76350, at a load current of 100 mA and a maximum temperature of 85°C are V_{F-max} = 0.2 V, V_{DO-max} = 0.2 V, and V_{O_FullLoad_max} = 5.175 V, I_{OUT-max} = 0.1A.

Assume that the input power supply accuracy is ±2%, V_{IN-min} = 3.234 V. From the NSIP6051 data sheet with R_{DS-max} = 1.27Ω,

I_{D-max} = 350 mA.

Inserting in these values and do the calculation:

$$n_{min} = 1.031 \times \frac{0.2V + 0.2V + 5.175V}{3.234V - 1.5\Omega \times 350mA} = 2.12. \tag{10}$$

11.2.1.4.3 Recommended transformer configuration solution

The following circuits are recommended. Use the unstable output voltage circuit in Figure 11.3 or stable output voltage in Figure 11.4.

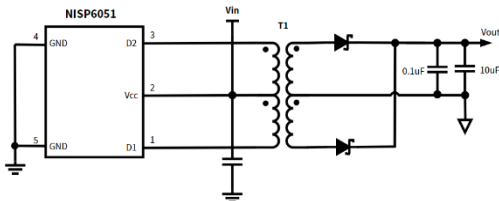

Figure 11.3 Unstable output voltage and low load current

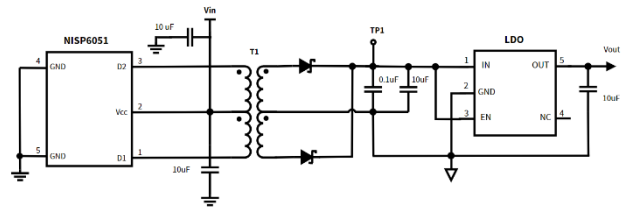

Figure 11.4 Stable output voltage and wide load current

Recommended transformer models can be found in NSIP6051 Demo Use Guide document.

12. Layout

12.1 Layout Guidelines

- The recommended capacitance value of the V_{IN} pin ranges from $1\mu\text{F}$ to $10\mu\text{F}$ and should be connected to the ground using a low ESR ceramic bypass capacitor.
- Refer to Figure 12.1 for PCB layout. The GND pin of the device should be connected to the PCB GND plane using two vias to achieve minimal inductance.
- The connection of the device D1 and D2 pins to the primary terminal of the transformer, and the connection of the device V_{CC} pins to the center tap of the transformer must be as close as possible to reduce the inductance of the wire.
- The recommended rectifier diode is the Schottky diode, which has a low forward voltage in the 20 mA to 100 mA current range to maximize efficiency.
- The device VCC pins and transformer center taps must be buffered to GND using a low ESR ceramic bypass capacitor. The recommended capacitors should have a voltage rating of at least 16V and capacitance values ranging from $1\mu\text{F}$ to $10\mu\text{F}$. The dielectric must be X5R or X7R.
- The V_{OUT} pins must be buffered to ISO ground by a low ESR ceramic bypass capacitor. It is recommended to use $0.1\mu\text{F}$ in parallel with $10\mu\text{F}$. Capacitors must have a minimum 16V rated voltage and X5R or X7R dielectrics.

12.2 Layout Example

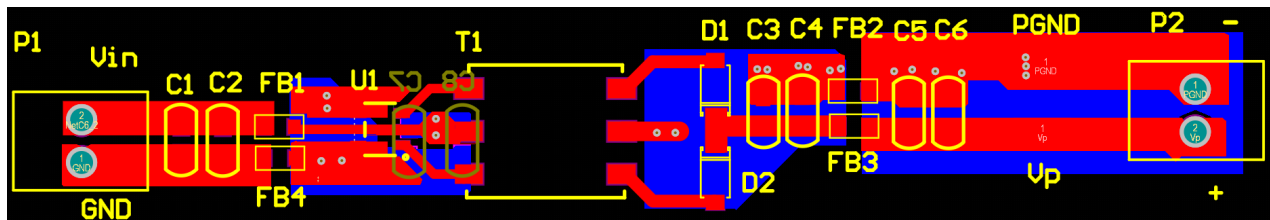
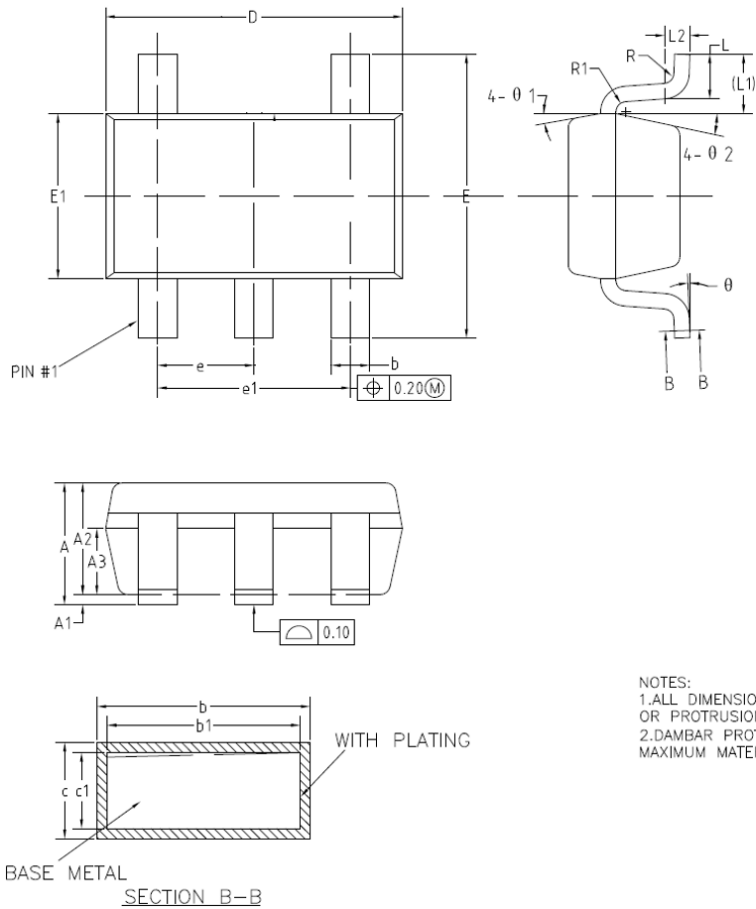

Figure 12.1 Layout Example of 2-Layer Board (NSIP6051)

13. Package Information



COMMON DIMENSIONS
(UNITS OF MEASURE=MILLIMETER)

SYMBOL	MIN	NOM	MAX
A	—	—	1.25
A1	0	—	0.15
A2	1.00	1.10	1.20
A3	0.60	0.65	0.70
b	0.34	—	0.45
b1	0.34	0.38	0.41
c	0.12	—	0.20
c1	0.12	0.15	0.16
D	2.826	2.926	3.026
E	2.60	2.80	3.00
E1	1.526	1.626	1.700
e	0.90	0.95	1.00
e1	1.80	1.90	2.00
K	0	—	0.20
L	0.30	0.40	0.60
L1	0.59REF		
L2	0.25BSC		
M	0.10	0.15	0.20
R	0.05	—	0.20
R1	0.05	—	0.20
theta	0°	—	8°
theta 1	8°	10°	12°
theta 2	10°	12°	14°

NOTES:
 1. ALL DIMENSIONS REFER TO JEDEC STANDARD MO-178 AA DO NOT INCLUDE MOLD FLASH OR PROTRUSIONS.
 2. DAMBAR PROTRUSION SHALL BE 0.08mm TOTAL IN EXCESS OF THE "b" DIMENSION AT MAXIMUM MATERIAL CONDITION.

Figure 13.1 SOT23-5 Package Shape and Dimension in millimeters

14. Order Information

Part Number	Operating Temperature Range	Marking Information	MSL	Package Type	Package Drawing	SPQ
NSIP6051-DSTAR	(-40 to 125) °C	051D	1	SOT23-5L	SOT23-5L	3000

15. Documentation Support

Part Number	Product Folder	Datasheet	Application Note
NSIP6051-DSTAR	Click here	Click here	Click here

17. Revision History

Revision	Description	Date
1.0	Initial Version	2024/5/13
1.1	Update protection current threshold, quadrant designations of tape and reel information.	2025/7/10

IMPORTANT NOTICE

The information given in this document (the “Document”) shall in no event be regarded as any warranty or authorization of, express or implied, including but not limited to accuracy, completeness, merchantability, fitness for a particular purpose or infringement of any third party’s intellectual property rights.

Users of this Document shall be solely responsible for the use of NOVOSENSE’s products and applications, and for the safety thereof. Users shall comply with all laws, regulations and requirements related to NOVOSENSE’s products and applications, although information or support related to any application may still be provided by NOVOSENSE.

This Document is provided on an “AS IS” basis, and is intended only for skilled developers designing with NOVOSENSE’ products. NOVOSENSE reserves the rights to make corrections, modifications, enhancements, improvements or other changes to the products and services provided without notice. NOVOSENSE authorizes users to use this Document exclusively for the development of relevant applications or systems designed to integrate NOVOSENSE’s products. No license to any intellectual property rights of NOVOSENSE is granted by implication or otherwise. Using this Document for any other purpose, or any unauthorized reproduction or display of this Document is strictly prohibited. In no event shall NOVOSENSE be liable for any claims, damages, costs, losses or liabilities arising out of or in connection with this Document or the use of this Document.

For further information on applications, products and technologies, please contact NOVOSENSE (www.novosns.com).

Suzhou Novosense Microelectronics Co., Ltd