

Product Overview

The NSCSA21xA series are micropower, precision current sense amplifier with a very wide input common mode range. The NSCSA21xA monitors Bidirectional current via the voltage across an external sense resistor. The input common mode voltage range extends from -2V to 28V, with respect to the negative supply voltage (V₋). This allows for the NSCSA21xA to be used for both low and high side current-sensing applications.

Four fixed gains are available: 50 V/V, 75 V/V, 100 V/V or 200 V/V. The four gain selections offer flexibility in the choice of the external current-sense resistor. The very low $\pm 5\mu\text{V}$ (typ) input offset voltage allows small 25mV to 100mV full-scale V_{SHUNT} voltage for very low power loss at full-current measurement.

The NSCSA21xA series operates from a single 2.7V to 28V supply, drawing a typical of 260 μA of supply current. The operating temperature range is specified from -40°C to 125°C, and the NSCSA21xA is offered in a space-saving SC70-6 package.

Key Features

- Survival Common-Mode Input Range: -28V to 28V
- Supply Voltage Range: 2.7V to 28V
- Low Offset Voltage: $\pm 5\mu\text{V}$ (Typical)
- Gain Error: $\pm 0.1\%$ (Typical)
- Operate Current: 260 μA (Typical)
- Gain Options:
 - NSCSA213A: 50 V/V
 - NSCSA215A: 75 V/V
 - NSCSA214A: 100 V/V
 - NSCSA210A: 200 V/V
- SC70 Package
- ROHS&REACH Compliance

Applications

- Battery Management Systems
- Motor Controls
- Power-System Monitors
- Overcurrent and Fault Detection
- Notebook Computers
- Portable and Battery-Backup Systems

Device Information

Part Number	Gain	Package	Body Size
NSCSA213A-DSCAR	50	SC70-6	2mm×1.25mm
NSCSA215A-DSCAR	75	SC70-6	2mm×1.25mm
NSCSA214A-DSCAR	100	SC70-6	2mm×1.25mm
NSCSA210A-DSCAR	200	SC70-6	2mm×1.25mm

Typical Application

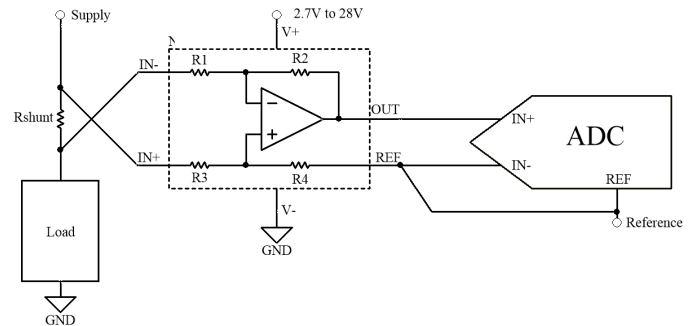

Part Number	Gain	R1 and R3	R2 and R4
NSCSA213A	50	20k Ω	1M Ω
NSCSA215A	75	13.3k Ω	1M Ω
NSCSA214A	100	10k Ω	1M Ω
NSCSA210A	200	5k Ω	1M Ω

INDEX

1. PIN CONFIGURATION AND FUNCTIONS	3
2. SPECIFICATIONS	4
2.1. ABSOLUTE MAXIMUM RATINGS	4
2.2. ESD RATINGS	4
2.3. RECOMMENDED OPERATING CONDITIONS	4
2.4. THERMAL INFORMATION	4
3. ELECTRICAL CHARACTERISTICS	5
4. TYPICAL PERFORMANCE CHARACTERISTICS	7
5. FUNCTION DESCRIPTION	11
5.1. OVERVIEW	11
6. APPLICATION NOTE	12
6.1. TYPICAL APPLICATION CIRCUIT	12
7. PACKAGE INFORMATION	13
8. ORDER INFORMATION	14
9. TAPE AND REEL INFORMATION	15
10. REVISION HISTORY	16

1. Pin Configuration and Functions

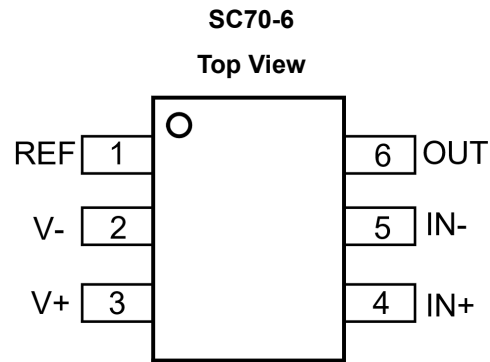

<i>Pin No.</i>	<i>Symbol</i>	<i>Type</i>	<i>Function</i>
1	REF	I	Reference voltage, 0 V to V+
2	V-	GND	Ground
3	V+	Power	Supply voltage, 2.7 V to 28 V
4	IN+	I	Non-inverting Input
5	IN-	I	Inverting input
6	OUT	O	Output voltage

2. Specifications

2.1. Absolute Maximum Ratings

Parameters	Symbol	Min	Max	Unit
Supply Voltage ((V ₊) - (V ₋))	V _S	-0.3	30	V
Voltage at IN- and IN+ Pins	V _{IN+} , V _{IN-}	-28	30	V
Voltage at REF Pins	V _{REF}	(V ₋) - 0.3	30	V
Voltage at Output Pins	V _{OUT}	(V ₋) - 0.3	(V ₊) + 0.3	V
Storage Temperature	T _{stg}	-60	150	°C
Maximum Junction Temperature			150	°C

2.2. ESD Ratings

Ratings		Value	Unit
Electrostatic discharge	● Human body model (HBM), per ANSI/ESDA/JEDEC JS-001	±3000	V
	● Charged device model (CDM), per JEDEC specification JESD22-C101	±2000	V

2.3. Recommended Operating Conditions

Parameters	Symbol	Min	Typ	Max	Unit
Power Supply Voltage	V _S		5		V
Common-Mode Input Voltage	V _{CM}		12		V
Operation Temperature Range	T _A	-40		125	°C

2.4. Thermal Information

Parameters	Symbol	SC70-6	Unit
Junction-to-ambient thermal resistance	θ _{JA}	179.8	°C/W
Junction-to-case(top) thermal resistance	θ _{JC(top)}	129.4	°C/W
Junction-to-board thermal resistance	θ _{JB}	74.5	°C/W

3. Electrical Characteristics

At $T_A = +25^\circ\text{C}$, $V_{\text{SHUNT}} = V_{\text{IN}+} - V_{\text{IN}-}$, and, $V_S = (V_+) - (V_-) = 5\text{V}$, $V_{\text{IN}+} = 12\text{V}$, $V_{\text{SHUNT}} = 0\text{mV}$, and $V_{\text{REF}} = V_S / 2$, unless otherwise noted.

Parameters	Symbol	Condition	Min	Typ	Max	Unit	
INPUT							
Common-Mode Input Range	V_{CM}		-2		28	V	
Common-Mode Rejection Ratio	CMRR	$V_{\text{CM}} = -1.5\text{V to } 28\text{V}$ $T_A = -40^\circ\text{C to } 125^\circ\text{C}^1$	Gain=50	100	120	dB	
			Gain=75				
Offset Voltage, RTI ²	V_{OS}	NSCSA213A (Gain=50)			± 15	± 90	
			NSCSA215A (Gain=75)			± 15	± 70
			NSCSA214A (Gain=100)			± 15	± 70
			NSCSA210A (Gain=200)			± 5	± 40
Offset Voltage Drift, RTI ²	dV_{OS}/dT	$T_A = -40^\circ\text{C to } 125^\circ\text{C}^3$		± 0.1	± 0.5	$\mu\text{V}/^\circ\text{C}$	
Input Bias Current	I_B			10	15	μA	
Input offset current	I_{OS}			± 0.01		μA	
OUTPUT							
Gain Error	GE	$V_{\text{SHUNT}} = -5\text{mV to } 5\text{mV}$ $T_A = -40^\circ\text{C to } 125^\circ\text{C}^1$		± 0.1	± 0.5	%	
Gain Drift		$T_A = -40^\circ\text{C to } 125^\circ\text{C}^3$		± 3	± 10	ppm/ $^\circ\text{C}$	
Nonlinearity Error				± 0.01		%	
Maximum capacitive load		No sustained oscillation		1		nF	
VOLTAGE OUTPUT							
Swing to V+		$R_L = 10\text{ k}\Omega$ to (V.) $T_A = -40^\circ\text{C to } 125^\circ\text{C}^1$		$(V_+) - 0.05$	$(V_+) - 0.2$	V	
Swing to V-		$R_L = 10\text{ k}\Omega$ to (V.) $T_A = -40^\circ\text{C to } 125^\circ\text{C}^1$		$(V_-) + 5$	$(V_-) + 50$	mV	
FREQUENCY RESPONSE							
Input Voltage-Noise Density			NSCSA213A (Gain=50)		42	nV/ $\sqrt{\text{Hz}}$	
			NSCSA215A (Gain=75)		38		
			NSCSA214A (Gain=100)		36		
			NSCSA210A (Gain=200)		32		
Slew Rate	SR	$C_L = 10\text{ pF}$		2		V/ μs	
Bandwidth	BW	$C_L = 10\text{ pF}$	Gain=50		200	kHz	
			Gain=75		125		
			Gain=100		100		
			Gain=200		50		

¹ All devices are 100% production tested at $T_A = 25^\circ\text{C}$. All temperature limits are guaranteed by characterization results.

² RTI means referred to input

³ Not production tested, guaranteed by characterization results

Electrical Characteristics (continued)

At $T_A = +25^\circ\text{C}$, $V_{\text{SHUNT}} = V_{\text{IN+}} - V_{\text{IN-}}$, and, $V_S = (V+) - (V-) = 5\text{V}$, $V_{\text{IN+}} = 12\text{V}$, $V_{\text{SHUNT}} = 0\text{mV}$, and $V_{\text{REF}} = V_S / 2$, unless otherwise noted.

Parameters	Symbol	Condition	Min	Typ	Max	Unit
SUPPLY						
Supply Voltage Range	V_S	$T_A = -40^\circ\text{C}$ to 125°C ¹	2.7		28	V
Quiescent Current	I_Q	$T_A = +25^\circ\text{C}$		260		μA
		$T_A = -40^\circ\text{C}$ to 125°C ¹			320	
Power Supply Ratio	PSRR	NSCSA213A (Gain=50) NSCSA215A (Gain=75) NSCSA214A (Gain=100)	100	125		dB
		NSCSA210A (Gain=200)	110	135		

¹ All devices are 100% production tested at $T_A = 25^\circ\text{C}$. All temperature limits are guaranteed by characterization results.

4. Typical Performance Characteristics

at $T_A = +25^\circ\text{C}$, $V_{\text{SHUNT}} = V_{\text{IN}+} - V_{\text{IN}-}$, and, $V_S = (V+) - (V-) = 5\text{V}$, $V_{\text{IN}+} = 12\text{V}$, $V_{\text{SHUNT}} = 0\text{mV}$, and $V_{\text{REF}} = V_S / 2$, unless otherwise noted.

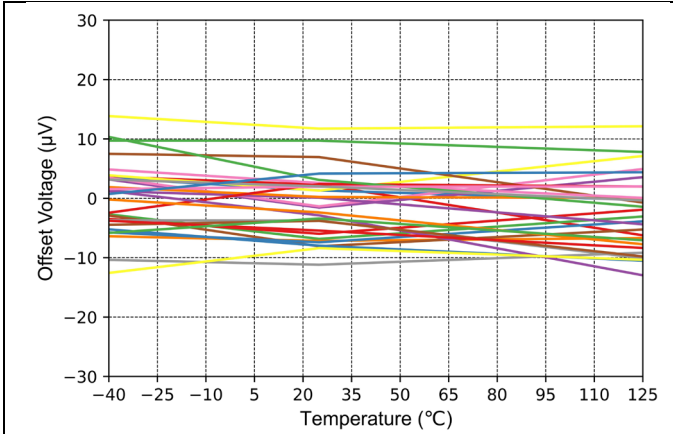

Figure 4-1 Input Offset Voltage vs Temperature

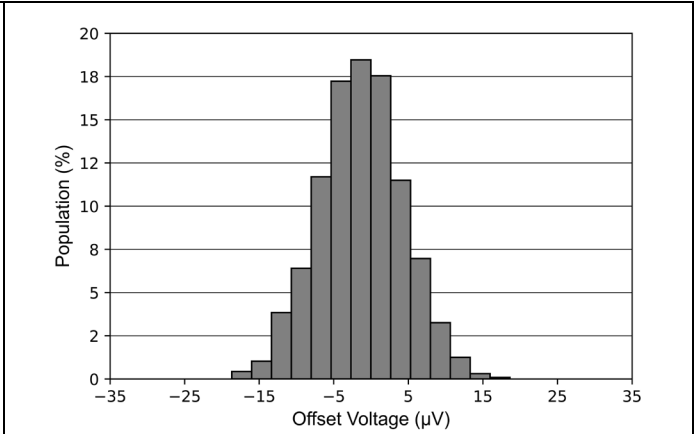

Figure 4-2 Input Offset Voltage Distribution

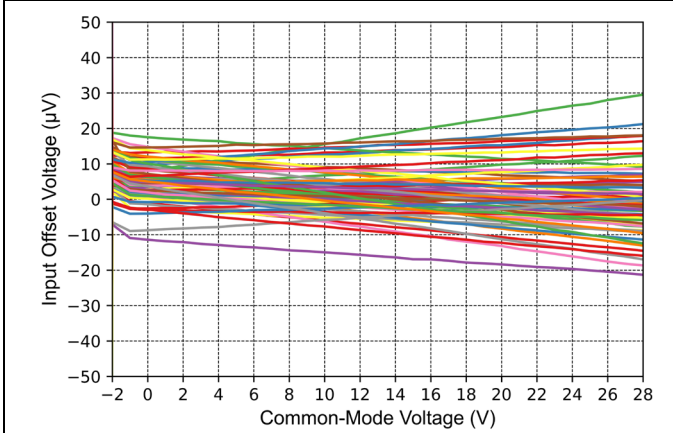

Figure 4-3 Input Offset Voltage vs Common-mode Voltage

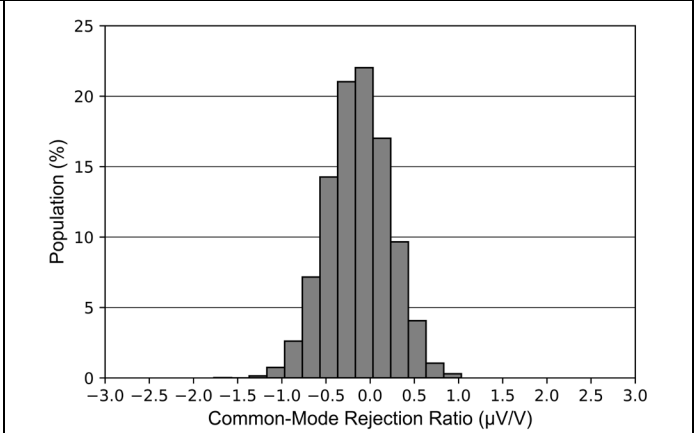

Figure 4-4 Common-Mode Rejection Ratio Distribution

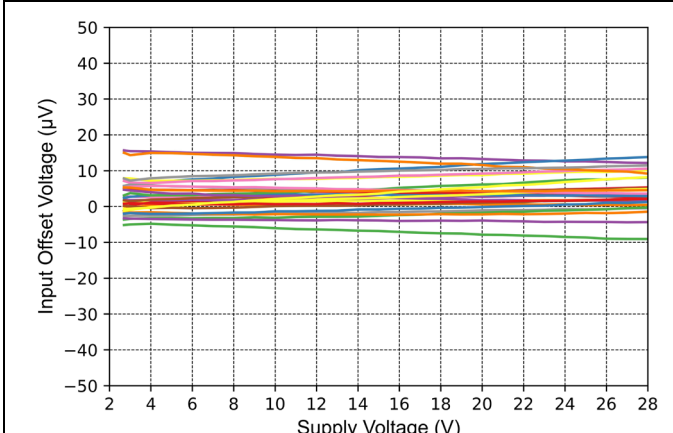

Figure 4-5 Input Offset Voltage vs Supply Voltage

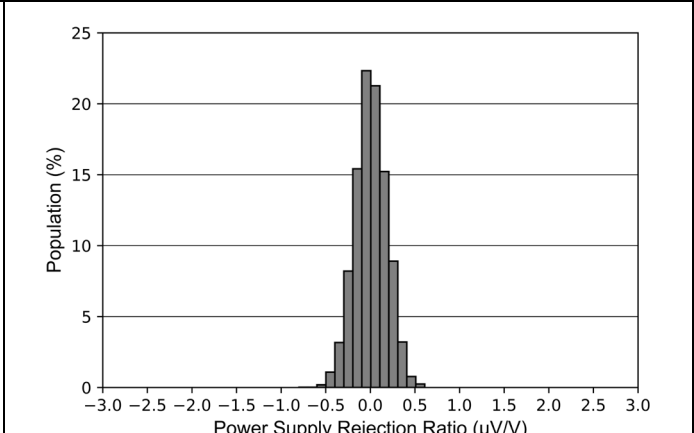

Figure 4-6 Power Supply Rejection Ratio Distribution

Typical Performance Characteristics (continued)

at $T_A = +25^\circ\text{C}$, $V_{\text{SHUNT}} = V_{\text{IN}+} - V_{\text{IN}-}$, and, $V_S = (V+) - (V-) = 5\text{V}$, $V_{\text{IN}+} = 12\text{V}$, $V_{\text{SHUNT}} = 0\text{mV}$, and $V_{\text{REF}} = V_S / 2$, unless otherwise noted.

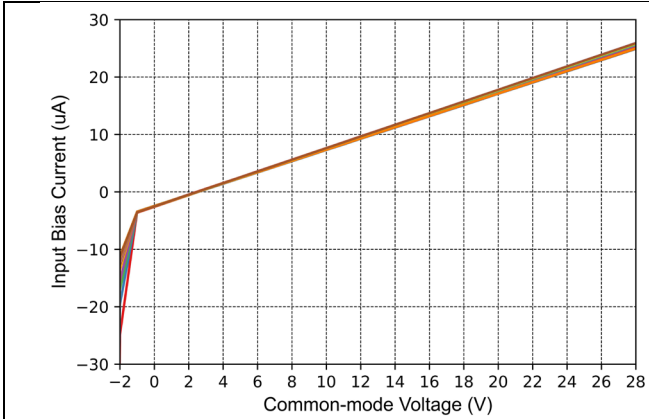

Figure 4-7 Input bias current vs Common-mode Voltage

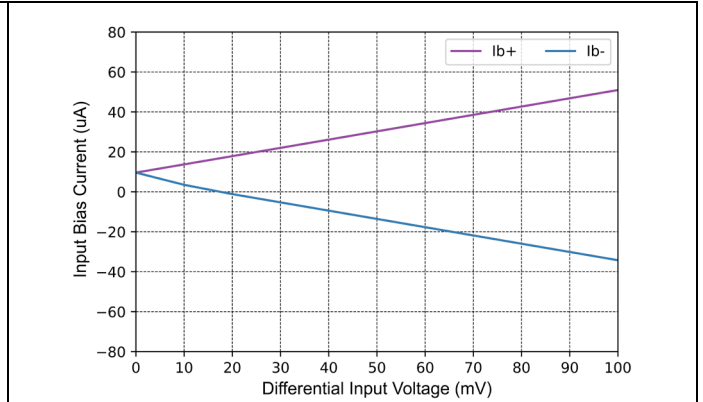

Figure 4-8 Input Bias Current vs Differential Input Voltage

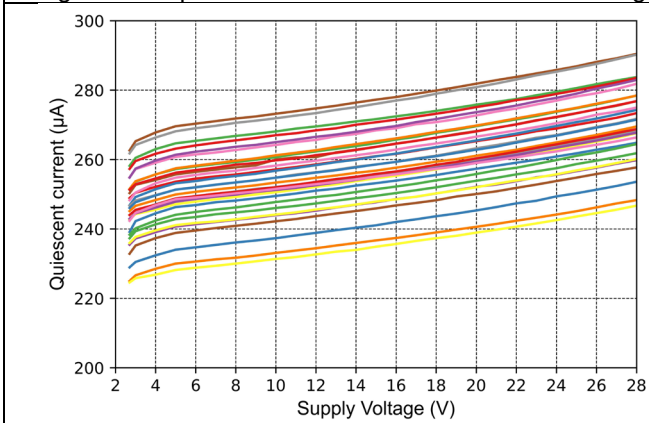

Figure 4-9 Quiescent Current vs Supply Voltage

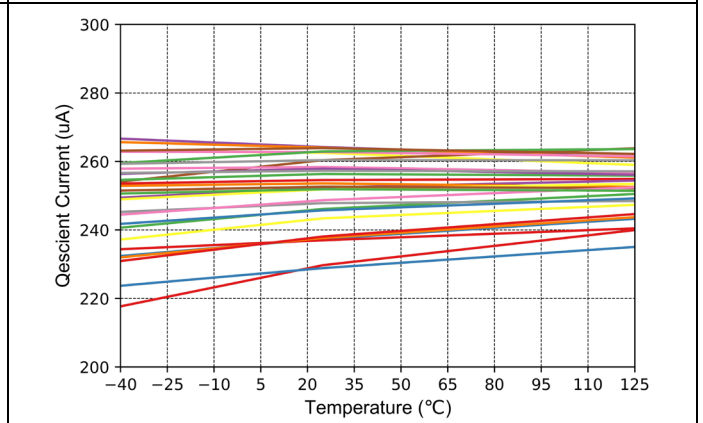

Figure 4-10 Quiescent Current vs Temperature

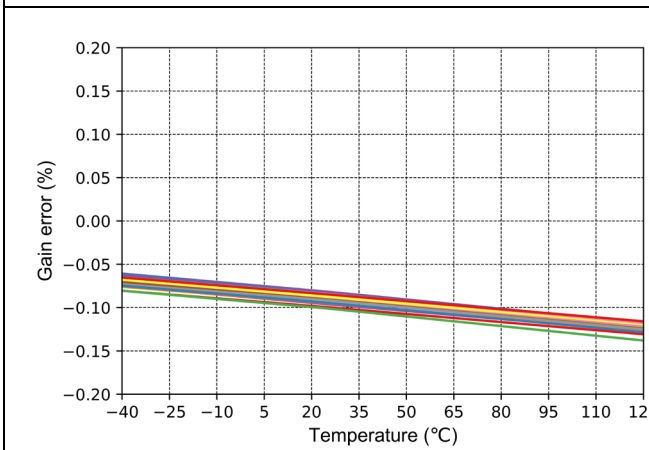

Figure 4-11 Gain Error vs Temperature

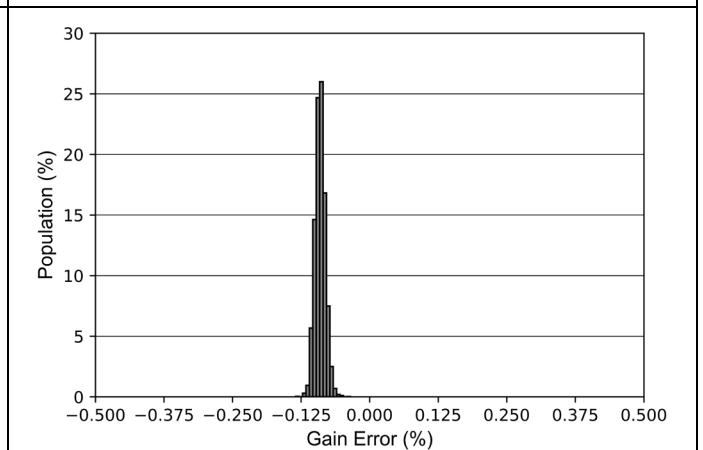

Figure 4-12 Gain Error Distribution

Typical Performance Characteristics (continued)

at $T_A = +25^\circ\text{C}$, $V_{\text{SHUNT}} = V_{\text{IN}+} - V_{\text{IN}-}$, and, $V_S = (V+) - (V-) = 5\text{V}$, $V_{\text{IN}+} = 12\text{V}$, $V_{\text{SHUNT}} = 0\text{mV}$, and $V_{\text{REF}} = V_S / 2$, unless otherwise noted.

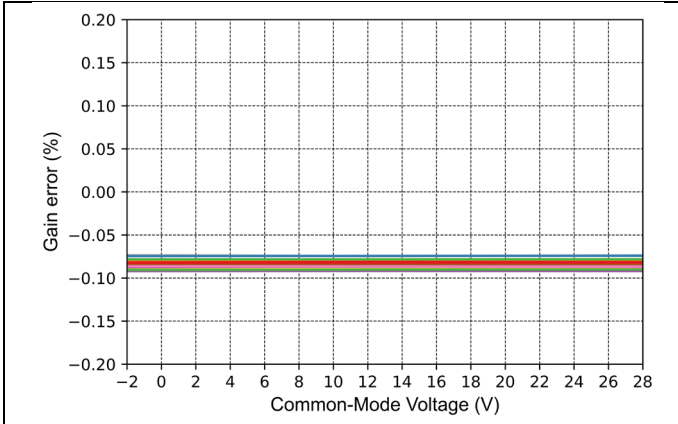

Figure 4-13 Gain Error vs Common-mode Voltage

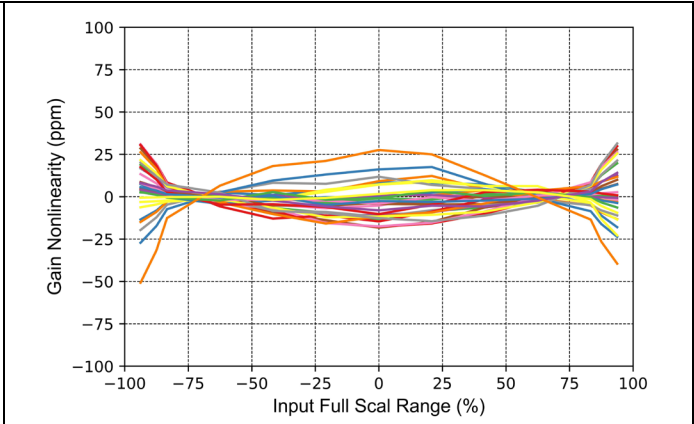

Figure 4-14 Gain Nonlinearity error vs Input Range

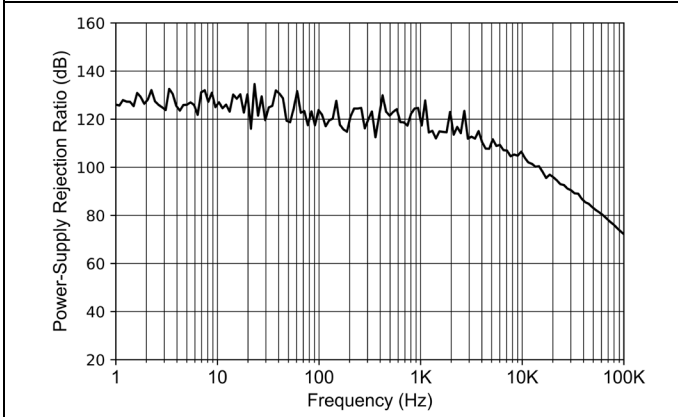

Figure 4-15 Power-Supply Rejection Ratio vs Frequency

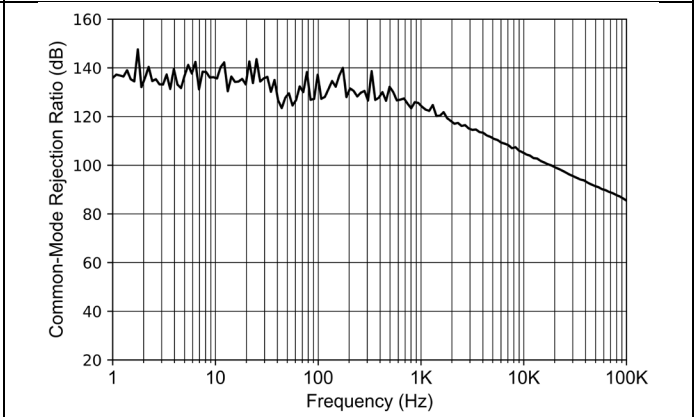

Figure 4-16 Common-Mode Rejection Ratio vs Frequency

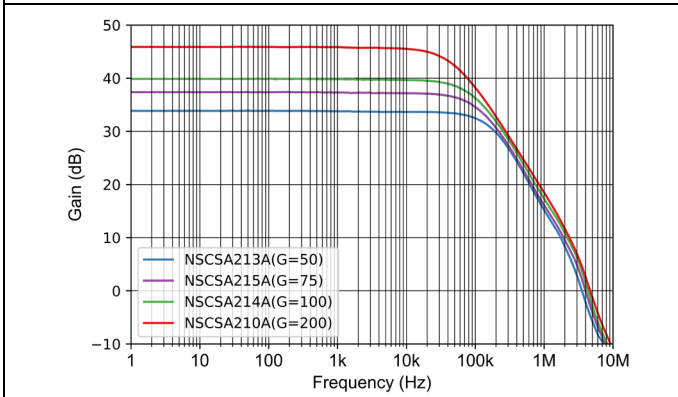

Figure 4-17 Gain vs Frequency

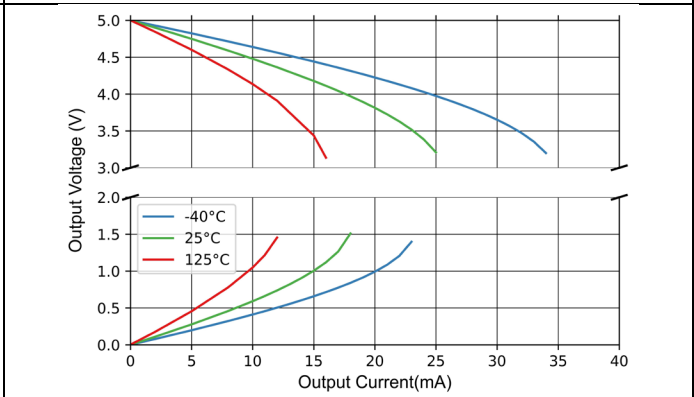

Figure 4-18 Output Voltage vs Output Current

Typical Performance Characteristics (continued)

at $T_A = +25^\circ\text{C}$, $V_{\text{SHUNT}} = V_{\text{IN}+} - V_{\text{IN}-}$, and, $V_S = (V+) - (V-) = 5\text{V}$, $V_{\text{IN}+} = 12\text{V}$, $V_{\text{SHUNT}} = 0\text{mV}$, and $V_{\text{REF}} = V_S / 2$, unless otherwise noted.

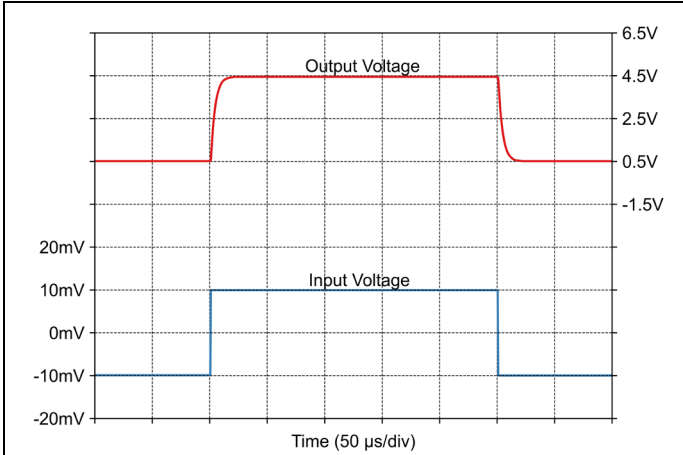

Figure 4-19 Step Response

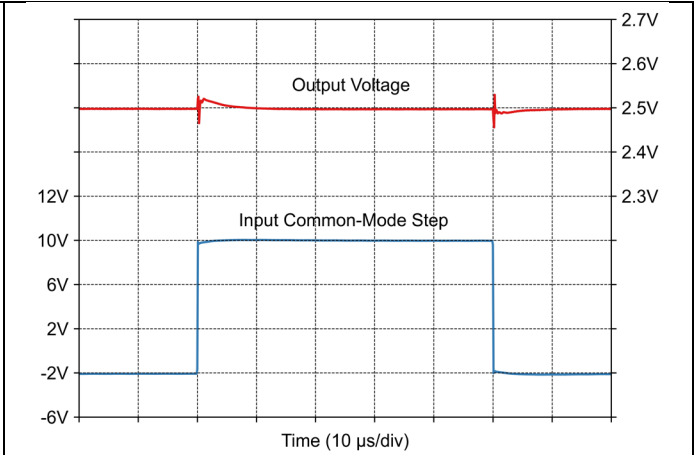

Figure 4-20 Enhanced PWM Rejection

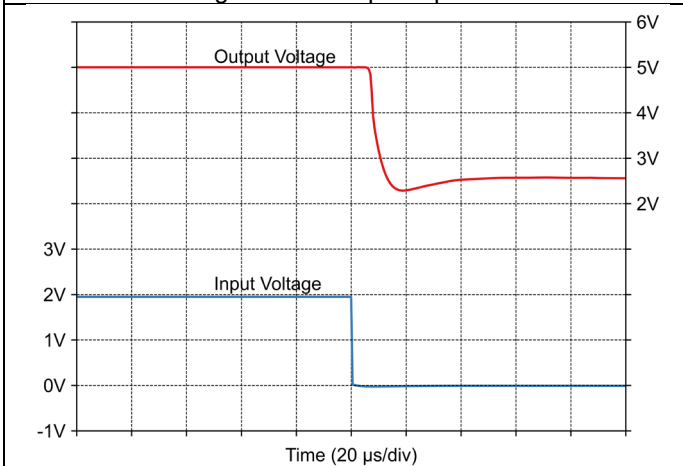

Figure 4-21 Noninverting Differential Input Overload Recovery

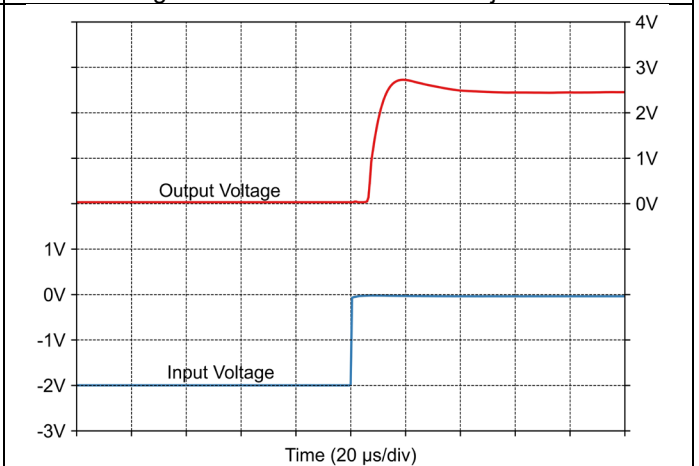

Figure 4-22 Inverting Differential Input Overload Recovery

5. Function Description

5.1. Overview

The NSCSA21xA series current sensor amplifiers offer a wide common-mode range from -2V to 28V, this current amplifier protects a main amplifier, 4 precisely matched resistors, oscillator, power on reset circuit, bandgap reference and LDO, and input common mode bias circuit.

The NSCSA21xA series are micropower, precision current sense amplifier with a very wide input common mode range. The NSCSA21xA monitors Bidirectional current via the voltage across an external sense resistor. The input common mode range extends from -2V to 28V, with respect to the negative supply voltage (V^-). This allows for the NSCSA21xA to be used for both low and high side current-sensing applications.

Four fixed gains are available: 50 V/V, 75 V/V, 100 V/V or 200 V/V. The four gain selections offer flexibility in the choice of the external current-sense resistor. The very low $\pm 5\mu\text{V}$ (typ) input offset voltage allows small 25mV to 100mV full-scale V_{SHUNT} voltage for very low power loss at full-current measurement.

The NSCSA21xA series operates from a single 2.7V to 28V supply, drawing a typical of 260 μA of supply current. The operating temperature range is specified from -40°C to 125°C, and the NSCSA21xA is offered in a space-saving SC70-6 package.

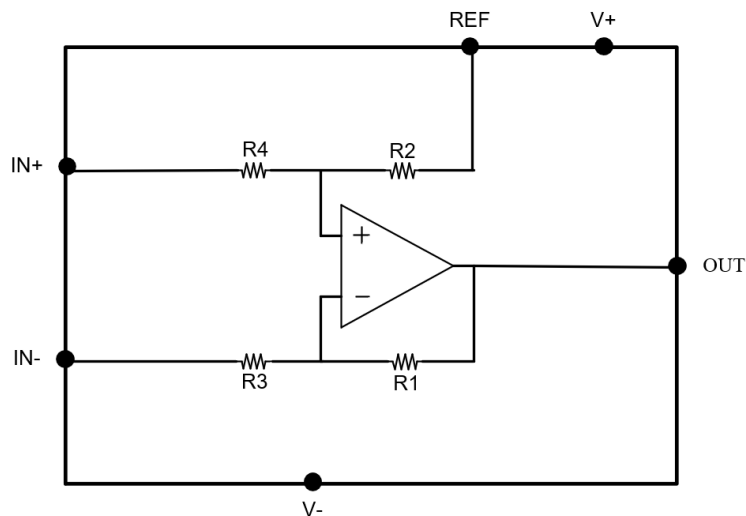

Figure 5-1 NSCSA21xA Functional Block Diagram

6. Application Note

6.1. Typical Application Circuit

The NSCSA21xA series are bidirectional current-sense amplifier. Figure 6-1 show typical application circuit.

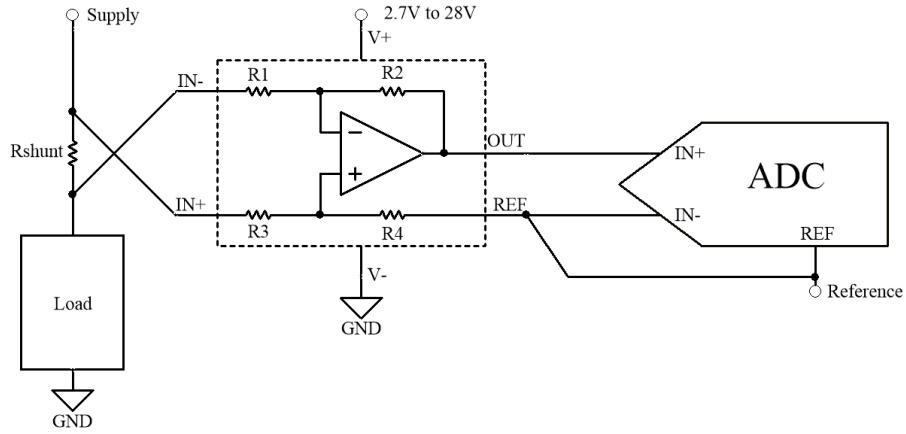

Figure 6-1 Typical Application Circuit

7. Package Information

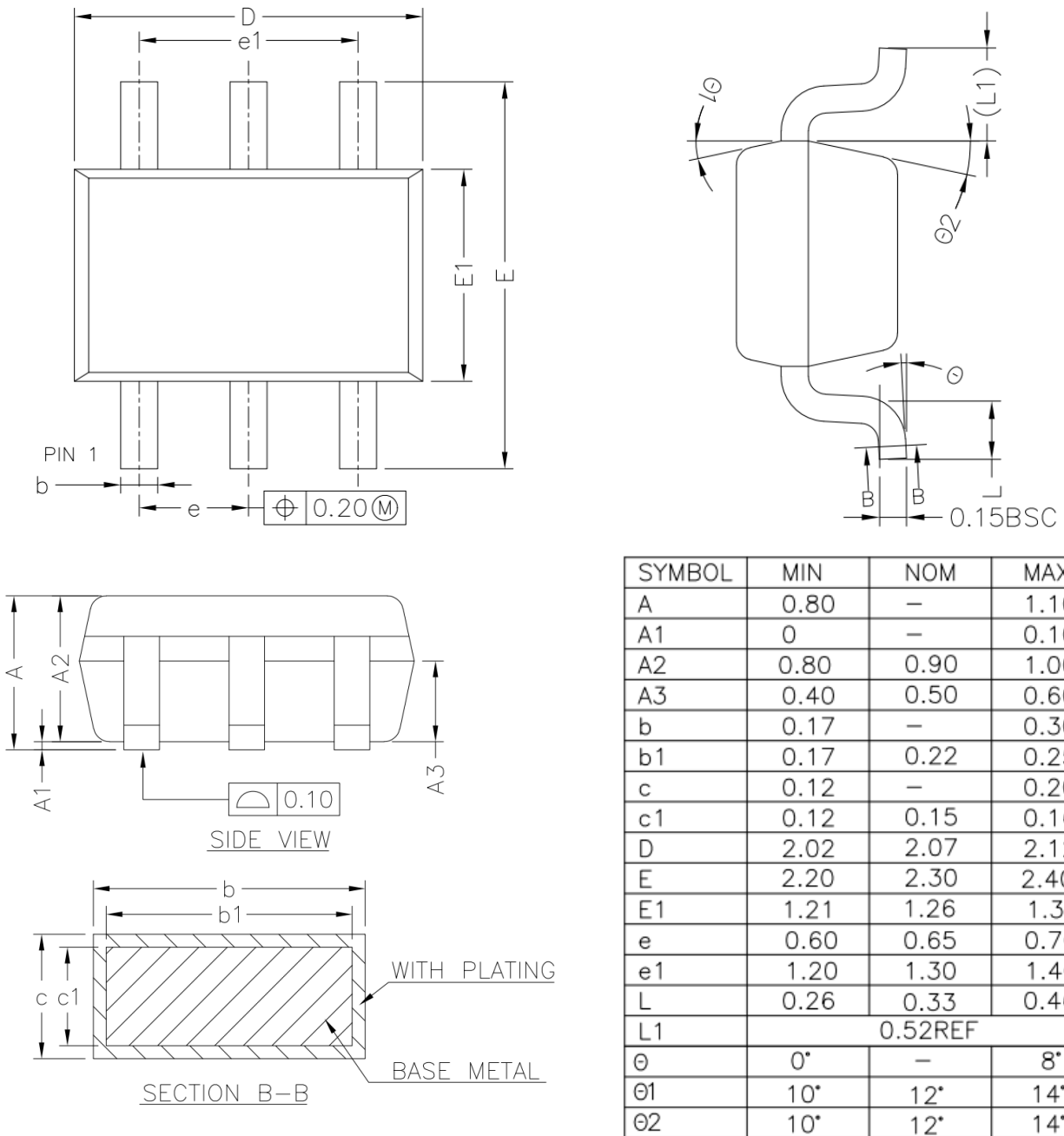

Figure 7-1 SC70-6 Package Shape and Dimension in millimeters

8. Order Information

<i>Part Number</i>	<i>Gain</i>	<i>Temperature</i>	<i>MSL</i>	<i>Package Type</i>	<i>SPQ</i>
NSCSA213A-DSCAR	50	-40 to 125°C	MSL1	SC70-6	3000
NSCSA215A-DSCAR	75	-40 to 125°C	MSL1	SC70-6	3000
NSCSA214A-DSCAR	100	-40 to 125°C	MSL1	SC70-6	3000
NSCSA210A-DSCAR	200	-40 to 125°C	MSL1	SC70-6	3000

9. Tape and Reel Information

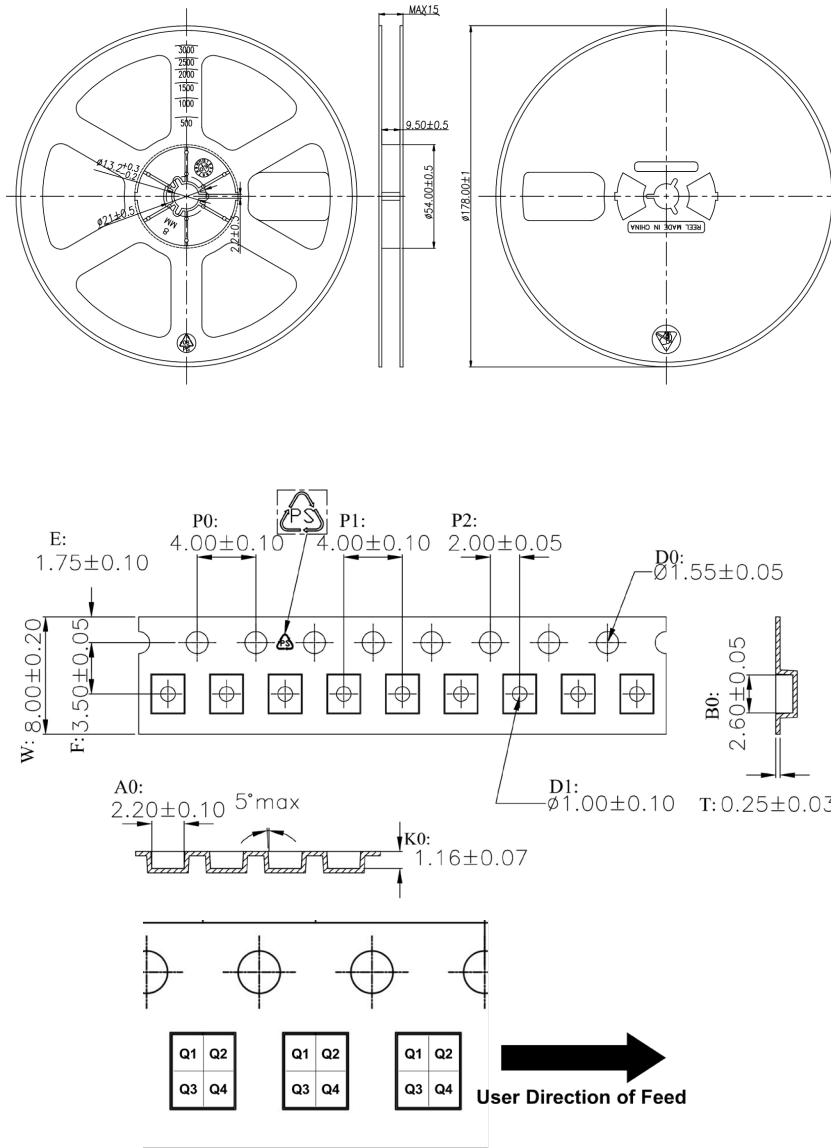

Figure 9-1 Tape and Reel Information of SC70-6

Device	Reel Diameter	Reel Width	W	A0	B0	P0	P1	P2	K0	D0	D1	PIN1 Quadrant
NSCSA213A -DSCAR	178	9.5	8.0	2.2	2.6	4.0	4.0	2.0	1.16	1.55	1.0	Q3
NSCSA215A -DSCAR	178	9.5	8.0	2.2	2.6	4.0	4.0	2.0	1.16	1.55	1.0	Q3
NSCSA214A -DSCAR	178	9.5	8.0	2.2	2.6	4.0	4.0	2.0	1.16	1.55	1.0	Q3
NSCSA210A -DSCAR	178	9.5	8.0	2.2	2.6	4.0	4.0	2.0	1.16	1.55	1.0	Q3

10. Revision History

<i>Revision</i>	<i>Description</i>	<i>Date</i>
1.0	Initial Version	2025/8

IMPORTANT NOTICE

The information given in this document (the “Document”) shall in no event be regarded as any warranty or authorization of, express or implied, including but not limited to accuracy, completeness, merchantability, fitness for a particular purpose or infringement of any third party’s intellectual property rights.

Users of this Document shall be solely responsible for the use of NOVOSENSE’s products and applications, and for the safety thereof. Users shall comply with all laws, regulations and requirements related to NOVOSENSE’s products and applications, although information or support related to any application may still be provided by NOVOSENSE.

This Document is provided on an “AS IS” basis, and is intended only for skilled developers designing with NOVOSENSE’s products. NOVOSENSE reserves the rights to make corrections, modifications, enhancements, improvements or other changes to the products and services provided without notice. NOVOSENSE authorizes users to use this Document exclusively for the development of relevant applications or systems designed to integrate NOVOSENSE’s products. No license to any intellectual property rights of NOVOSENSE is granted by implication or otherwise. Using this Document for any other purpose, or any unauthorized reproduction or display of this Document is strictly prohibited. In no event shall NOVOSENSE be liable for any claims, damages, costs, losses or liabilities arising out of or in connection with this Document or the use of this Document.

For further information on applications, products and technologies, please contact NOVOSENSE (www.novosns.com).

Suzhou NOVOSENSE Microelectronics Co., Ltd