

## High performance micro-controller With Integrated driver for DC , Stepper, and BLDC Motor Controlling Preliminary Datasheet (EN) Subject to change without notice

### Product Overview

The NSUC1610 is an ARM MCU with integrated 4 half-bridge drivers to control low-power DC motors. It can drive DC brushed motors, brush-less motors, stepper motors, etc. And It is widely used in the automotive markets .The chip conforms to the AEC-Q100 standard, and its junction temperature can support up to 175°C. Also, it is integrated with over-voltage protection function, and the LIN port can support -40V~40V, BVDD pin can support -0.3~40V. The core of the chip is Cortex-M3 based on the ARM instruction set. The core adopts Harvard structure and uses independent data bus and address bus, which can improve the efficiency of getting address and data.

### Key Features

- ARM Cortex-M3 32bit core
- 64KBytes Flash, 4KBytes SRAM, 512 Bytes EEPROM
- 32MHz high precision oscillator
- 35KHz Low power and low speed clock
- Operating voltage 5.5V~18V
- One 12-bit high precision ADC
- Two 8-bit current-limiting DAC
- Three rapid BEMF Comparators
- One SPI communication support 3 line / 4 line
- One UART peripheral
- LIN PHY module support LIN2.2 communication
- Three 16-bit input capture module
- Two 16-bit timer
- One window watchdog
- One digital watchdog
- Four output half bridge
- Four enhanced PWM output

- A high side drive controlled by software
- One 5V output ALDO
- One 1.8V output DLDO
- Two temperature sensor
- Four working modes : active, retention, idle and sleep mode
- Sleeping power consumption is less than 50 uA with all range of temperature
- AEC - Q100 Grade 0 reliability standard
- ROHS

### Applications

- Automotive low power water pump
- Automotive water valve
- Automotive air conditioning pendulum
- DC brush-less motor control
- DC brush motor control
- Stepper motor control

### Device Information

Part Number	Package	Body Size
NSUC1610-Q1QNR	QFN32	5mm × 5mm

### Functional Block Diagrams

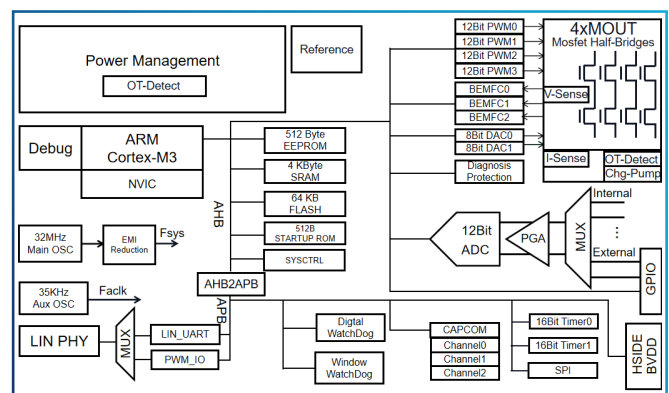

Figure 1. NSUC1610 Block Diagram

An important notice including intellectual properties, applications and other disclaimers, which constitutes an integral part hereof, is at the end of this preliminary datasheet.

**Sales Contact: [sales@novosns.com](mailto:sales@novosns.com); Further Information: [www.novosns.com](http://www.novosns.com)**

## IMPORTANT NOTICE

The information given in this document (the “Document”) shall in no event be regarded as any warranty or authorization of, express or implied, including but not limited to accuracy, completeness, merchantability, fitness for a particular purpose or infringement of any third party’s intellectual property rights.

Users of this Document shall be solely responsible for the use of NOVOSENSE’s products and applications, and for the safety thereof. Users shall comply with all laws, regulations and requirements related to NOVOSENSE’s products and applications, although information or support related to any application may still be provided by NOVOSENSE.

This Document is provided on an “AS IS” basis, and is intended only for skilled developers designing with NOVOSENSE’ products. NOVOSENSE reserves the rights to make corrections, modifications, enhancements, improvements or other changes to the products and services provided without notice. NOVOSENSE authorizes users to use this Document exclusively for the development of relevant applications or systems designed to integrate NOVOSENSE’s products. No license to any intellectual property rights of NOVOSENSE is granted by implication or otherwise. Using this Document for any other purpose, or any unauthorized reproduction or display of this Document is strictly prohibited. In no event shall NOVOSENSE be liable for any claims, damages, costs, losses or liabilities arising out of or in connection with this Document or the use of this Document.

For further information on applications, products and technologies, please contact NOVOSENSE ([www.novosns.com](http://www.novosns.com) ).

**Suzhou NOVOSENSE Microelectronics Co., Ltd**