

NOVOSENSE Automotive Solution

Enable the Electrification and Intellectualization of xEV



NOVOSENSE: Highly Robust and Reliable Analog and Mixed Signal IC Company



NOVOSENSE Microelectronics (NOVOSENSE, SSE Stock Code 688052) is a highly robust & reliable analog and mixed signal IC company. Since its establishment in 2013, the company has been focusing on sensor, signal chain, and power management, providing comprehensive semiconductor products and solutions, which are widely used in automotive, industrial, information communication and consumer electronics markets.

- Robust
- Reliable
- Keep Learning
- Persist in Long-term Value



With the mission of "Sense & Drive the Future, Build a Green, Smart and Connected World with Semiconductors" , the company is committed to providing chip-level solutions to link the digital world and the real world.

For more information and sample application, please visit: www.novosns.com



NOVOSENSE AUTOMOTIVE SOLUTION

CONTENTS

6 Automotive Solution Overview

Automotive OBC/DCDC, Traction Inverter, BMS Solution

9 Automotive OBC/DCDC Solution

10 Traction Inverter Solution

11 Battery Management System Solution

Automotive Thermal Management System

13 Heat Pump/Air Compressor Solution

14 PTC Solution

15 Distributed & Centralized Thermal Management System:
Product Selection

16 Automotive A/C Control Unit Solution

Automotive LED Driver Solution

18 Automotive LED Driver Solution

Body Control Module (BCM)

20 BCM Solution

Fuel Powertrain & Fuel Supply System Solution

22 Fuel Powertrain & Fuel Supply System Solution

NOVOSENSE Automotive Solution Overview

Smart Cockpit/Autonomous Driving

- Large screen rear light driver
- Antenna/camera load protection
- Universal power Buck/LDO
- Voltage monitoring
- Seat air bag MEMS pressure sensor
- High current pre-driver
- Digital relay

Body/Domain Control

- High and low side switch
- e-Fuse
- Magnetic switch position sensor
- Digital relay
- Multichannel half-bridge drive, pre-driver
- BDC/BLDC/stepping motor driver

Automotive Lighting

- Rear light & front light driver
- Ambient lighting driver
- Interior lighting drive
- Stepping motor driver

Fuel/Hybrid: Powertrain

- Engine intake manifold MEMS pressure sensor
- Fuel vapor MEMS pressure sensor
- Crankshaft ventilator MEMS pressure sensor
- Canister desorption MEMS pressure sensor
- Exhaust gas re-circulation MEMS pressure sensor
- GPF/DPF differential pressure MEMS pressure sensor



Automotive Solutions



New Energy Vehicle: Inverter/Powertrain

- Smart ISO drive/functional safety driver
- Digital isolator
- CAN/LIN/MiniSBC interface
- Magnetic current sensor
- Rotary transformer drive power amplifier
- Vacuum boost servo MEMS pressure sensor

New Energy Vehicle: BMS

- ISO & non-ISO power drive
- Digital isolator
- CAN/LIN/MiniSBC interface
- ISO digital relay
- ISO current and voltage sensing
- BPS battery pack thermal runaway MEMS pressure sensor

New Energy Vehicle: DCDC/OBC/PDU

- ISO & non-ISO power drive
- Digital isolator
- ISO current and voltage sensing
- CAN/LIN/MiniSBC interface
- Magnetic current sensor
- Current sense amplifier
- High/Low side driver& motor driver
- Power device - SiC

Thermal Management

- CAN/LIN/MiniSBC interface
- ISO & non-ISO power drive
- Digital isolator
- Electronic water valve, water pump and fan special motor drive
- Magnetic angle sensor
- Magnetic switch position sensor
- Multichannel half-bridge driver, pre-driver
- BDC/BLDC/stepping motor driver
- Pressure sensor signal conditioning chip
- Automotive micro&special motor driver SoC
- Power device - SiC

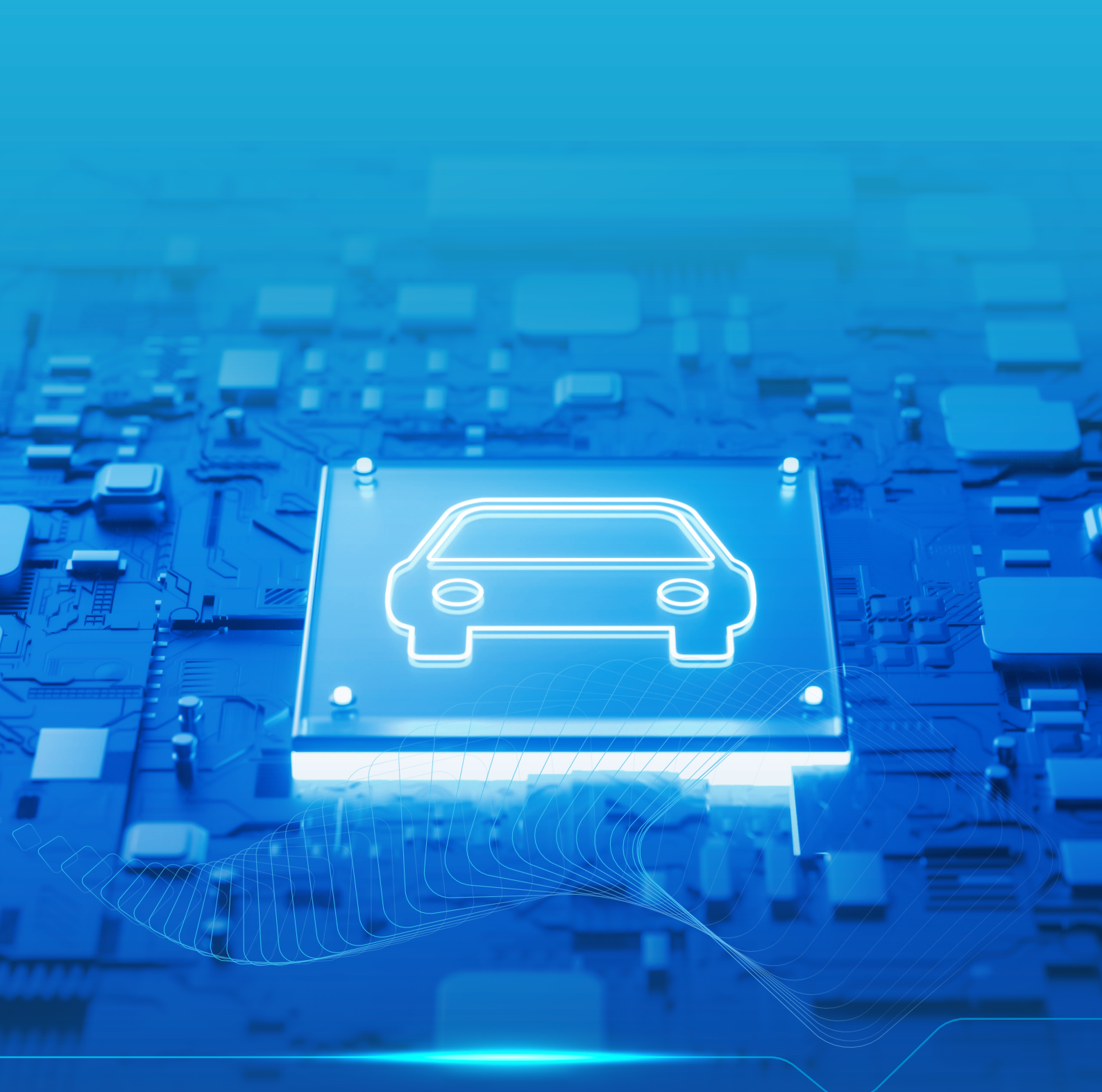

Automotive OBC/DCDC, Traction Inverter, BMS Solution

- Automotive OBC/DCDC Solution
- Traction Inverter Solution
- Battery Management System Solution

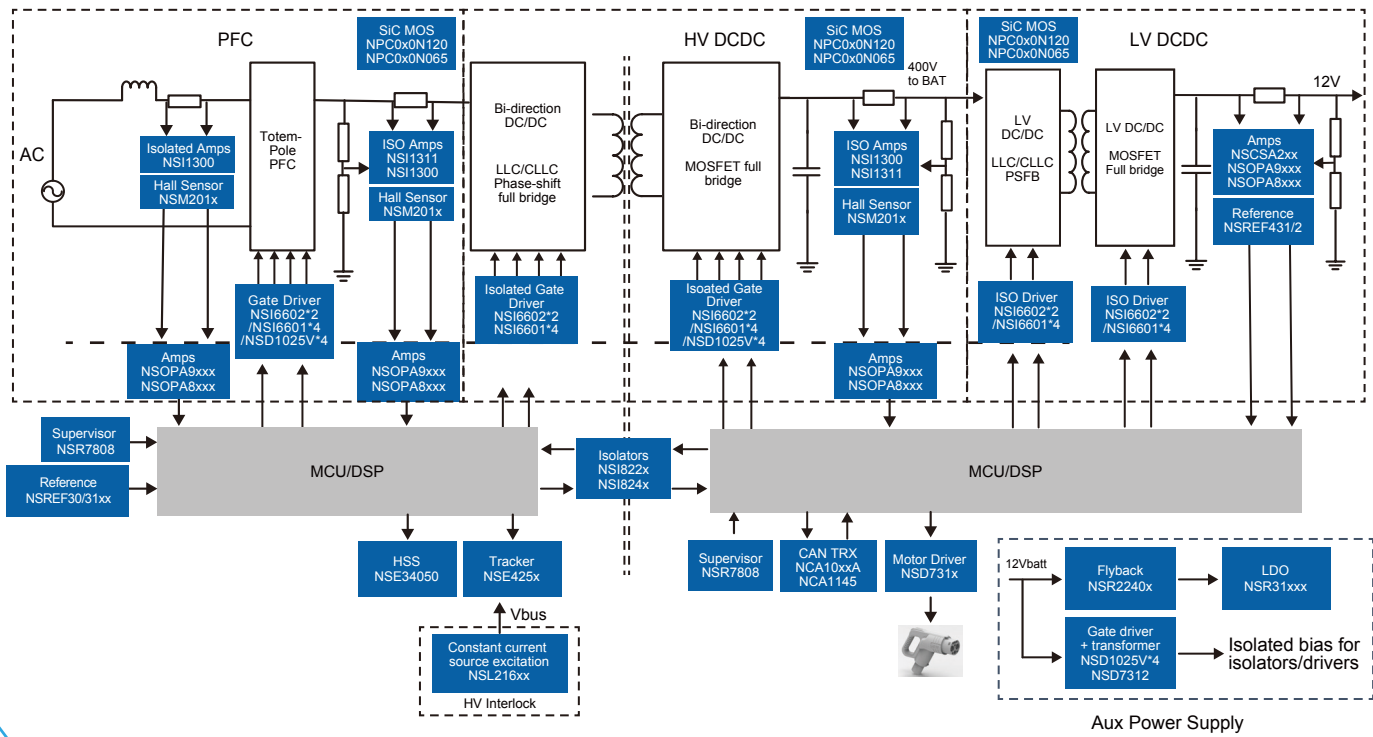

NOVOSENSE Part Number	Product	Application
NSI1300D25/05	±250mV ISO current sensing	PFC/DC-DC current sensing
NSI1311	0.1~2.1V ISO voltage sensing	PFC/DC-DC current sensing
NSM2011/NSM2013 /NSM2015	Hall current sensor	PFC/DC-DC current sensing
NSI6602/6622	4A ISO half-bridge driver	MOS/IGBT/SiC isolated driver
NSI6602V	6A ISO half-bridge driver	MOS/IGBT/SiC isolated driver
NSI6601M	Single-channel gate driver with miller clamp	MOS/IGBT/SiC isolated driver
NSD1624	120V half-bridge driver	MOS/IGBT/SiC half-bridge driver
NSD1025V	5A low-side gate driver	Isolation bias voltage of isolators/drivers
NSI82xx	Channel isolation	UART/SPI/CAN communication
NSD7312	DC brush motor driver	E-lock, DC/DC isolated bias
NSR31xxx	Low-power consumption LDO	Power supply
NSR2240x	Flyback controller	Aux power supply
NCA1042B	Automotive CAN FD TRX	CAN network
NCA1051A	Automotive CAN FD TRX	CAN network
NCA1043B	Automotive CAN FD TRX	CAN network
NCA1145	Automotive CAN FD TRX	CAN network
NSR7808	Voltage supervisor	MCU core voltage supervisor
NSREF30/31xx	Voltage reference	Voltage, current, temp sensing
NSE34050	High-side switch	Relay control
NSE425x	Voltage tracker	Sensor power supply
NPC0x0N120/065	SiC MOSFET	PFC, DCDC power conversion

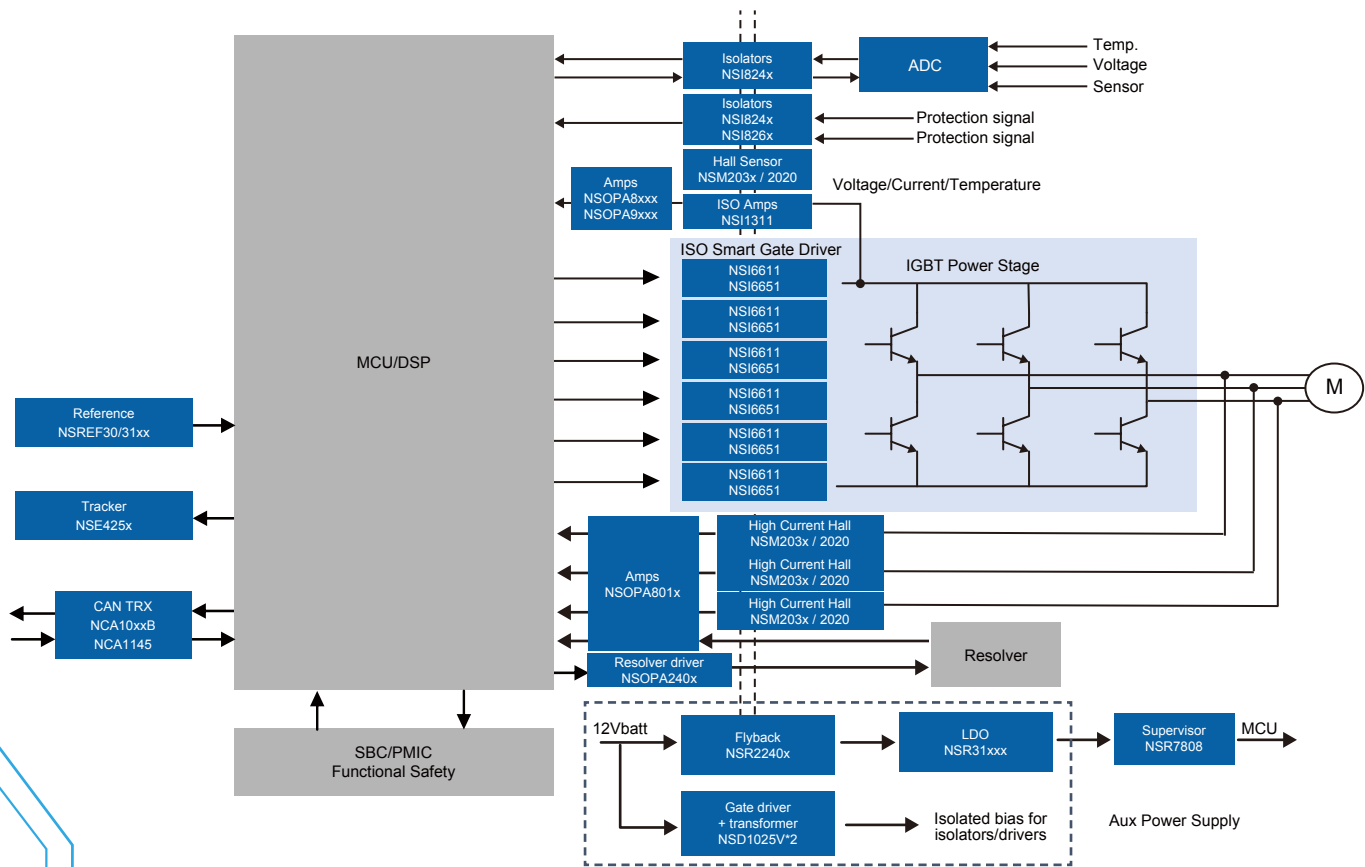

NOVOSENSE Part Number	Product	Application
NSI1300D25/05	±250mV ISO current amps	Bus/phase current sensing
NSM203x	Hall current sensor	Bus/phase current sensing
NSM2020	Coreless Hall current sensor	Bus/phase current sensing
NSI6602/6622	4A Half-bridge ISO gate driver	MOS/IGBT/SiC isolated driver
NSI6611/6651	Isolated smart gate driver	MOS/IGBT/SiC isolated driver
NSD1025V	30V 5A dual-channel low-side gate driver	Isolated bias for isolators/drivers
NSI82xx	Channel ISO	UART/SPI/CAN communication
NSR31xxx	Low power consumption LDO	Power supply
NSR2240x	Flyback controller	Aux power supply
NSI1311	0.1~2.1V input ISO voltage amps	Bus voltage sensing
NCA1042B	Automotive CAN FD TRX	CAN network
NCA1051A	Automotive CAN FD TRX	CAN network
NCA1043B	Automotive CAN FD TRX	CAN network
NCA1145	Automotive CAN FD TRX	CAN network
NSR7808	Voltage reference	MCU voltage monitoring
NSREF30/31xx	Voltage reference	Voltage,current,temp sensing
NSE425x	Voltage tracker	Sensor power supply

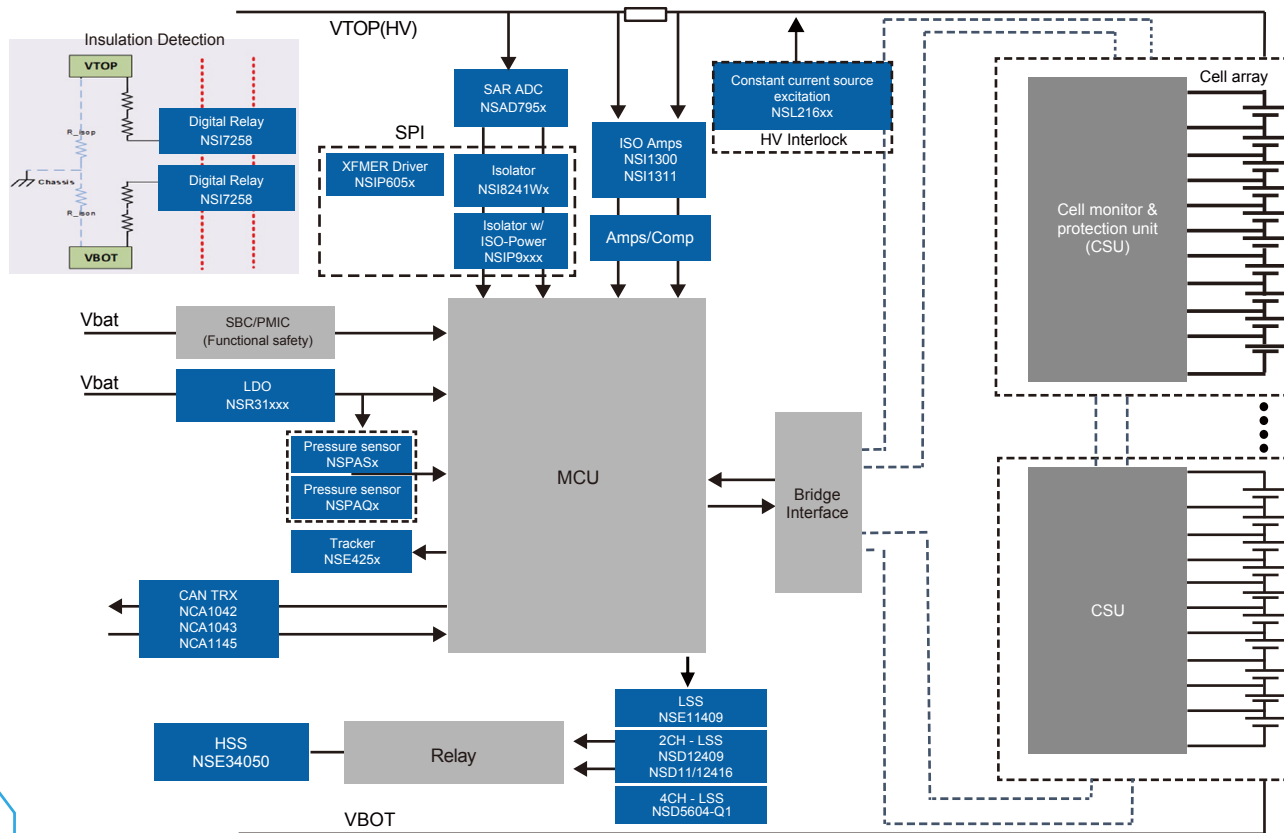

NOVOSENSE Part Number	Product	Application
NSI1300D25/05	±250mV ISO current sensing	PFC/DC-DC current sensing
NSI1311	0.1~2.1V ISO voltage sensing	Bus voltage sensing
NSI82xx	Channel ISO	UART/SPI/CAN ISO communication
NSE34050	High side switch	Relay control
NSE11409	Low side switch	Relay control
NSD12409	90m Ohm 2 Channel low side switch	Relay control
NSD12/11416	160m Ohm 1 Channel low side switch	Relay control
NSD5604	260m Ohm 4 Channel low side switch	Relay control
NCA1021S	Automotive LIN bus transceiver	LIN communication network
NCA1042B	Automotive CAN FD transceiver	CAN communication network
NCA1051A	Automotive CAN FD transceiver	CAN communication network
NCA1043B	Frame-awaken Automotive CAN FD transceiver	CAN communication network
NCA1145	Local-awaken Automotive CAN FD transceiver	CAN communication network
NSPASx	MEMS absolute pressure sensor	Battery pack
NSPAQ1	MEMS absolute pressure transducer with algorithm	Battery pack
NSI7258	Digital relay	Insulation detection
NSIP6051/6055	Push-pull topology transformer driver	Isolated power supply
NSIP9xxx	2/4-channel isolator with integrated isolated power supply	UART/SPI/CAN isolated communication
NSE425x	Voltage tracker	Sensor power supply



Automotive Thermal Management System

- Heat Pump/Air Compressor Solution
- PTC Solution
- Distributed & Centralized Thermal Management System: Product Selection
- Automotive A/C Control Unit Solution

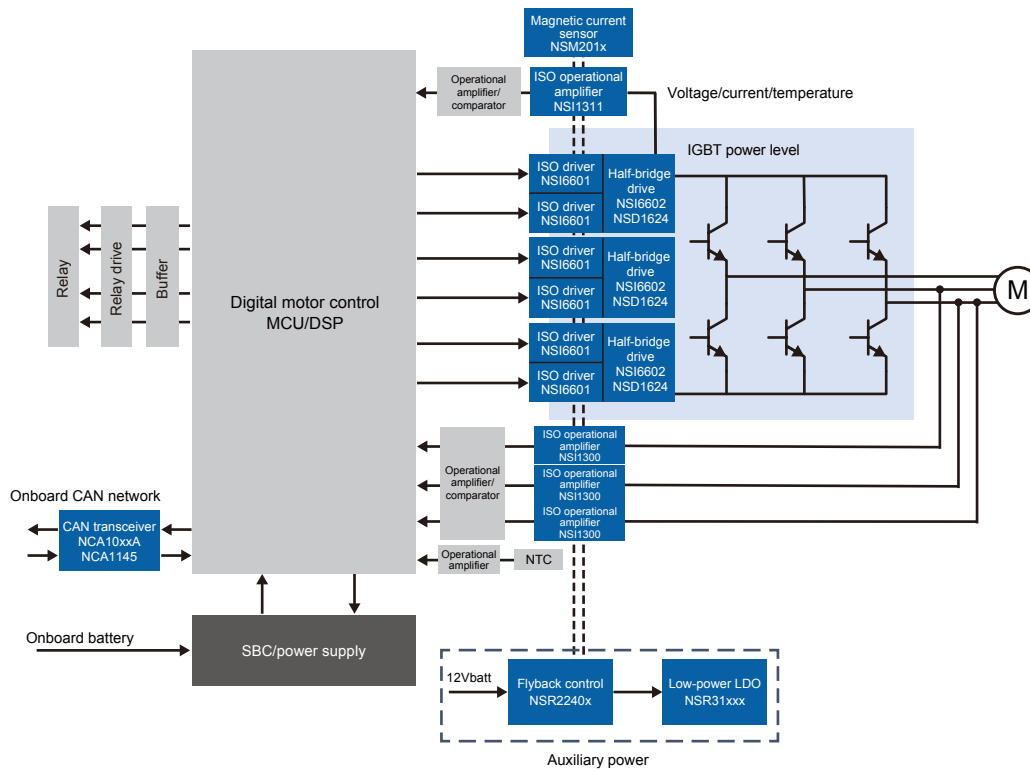

NOVOSENSE Part Number	Product	Application
NSI1300D25/05	±250mV ISO current sensing	PFC/DC-DC current sensing
NSM2011/NSM2013 /NSM2015	Hall current sensor	Motor bus current Phase current detection
NSI1311	0.1~2.1V ISO voltage sensing	Bus voltage sensing
NSI82xx	Channel ISO	UART/SPI/CAN ISO communication
NSR31xxx	Low power consumption LDO	Low-voltage domain power supply
NSR2240x	Auxiliary power flyback control	Auxiliary power supply
NSI6601	Single valve ISO driver	Power valve driver
NSI6602	4A ISO high-bridge driver	MOS/IGBT/SiC ISO driver
NSI6602V	6A ISO high-bridge driver	MOS/IGBT/SiC ISO driver
NSD1624	Non-ISO half-bridge driver	Power valve driver
NCA1042B	Automotive CAN FD transceiver	CAN communication network
NCA1051A	Automotive CAN FD transceiver	CAN communication network
NCA1043B	Frame-awaken Automotive CAN FD transceiver	CAN communication network
NCA1145	Local-awaken Automotive CAN FD transceiver	CAN communication network
NCA8T245	Buffer	PWM buffer, level switch

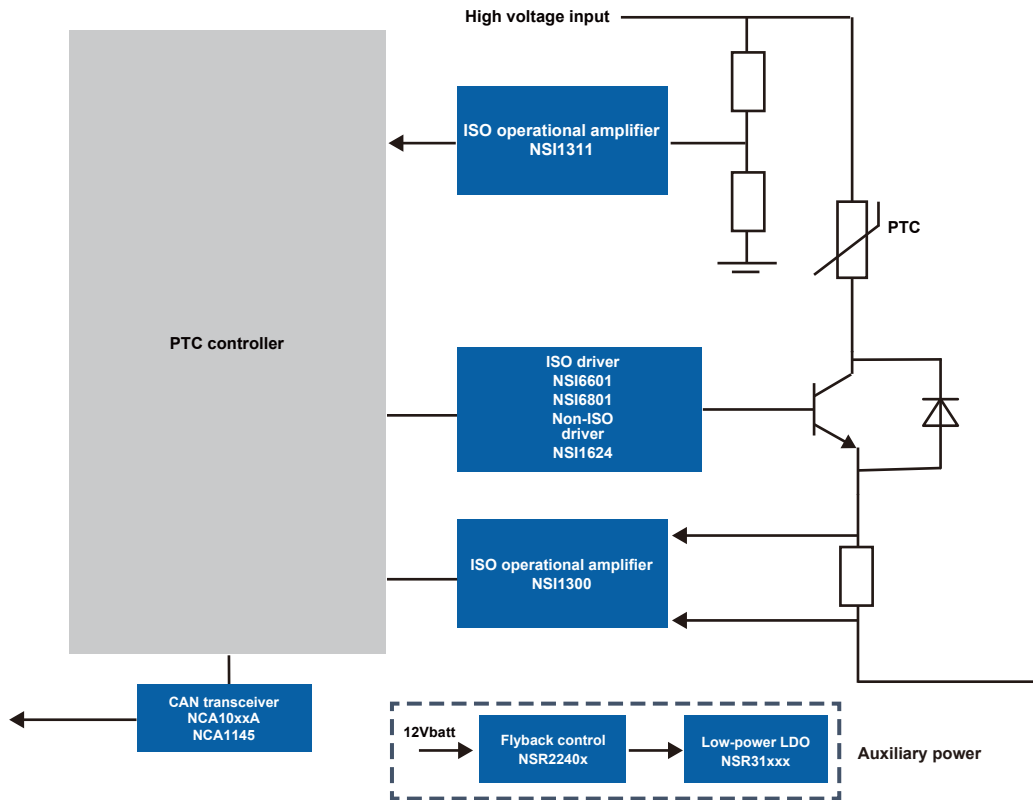

NOVOSENSE Part Number	Product	Application
NSI1300D25/05	±250mV ISO current sensing	PFC/DC-DC current sensing
NSI1311	0.1~2.1V ISO voltage sensing	Bus voltage sensing
NSI82xx	Channel ISO	UART/SPI/CAN ISO communication
NSR31xxx	Low-power LDO	Low-voltage domain power supply
NSR2240x	Auxiliary power flyback control	Auxiliary power supply
NSI6601	Single valve ISO driver	Power valve driver
NSD10151	Non-ISO single-channel low-side driver	Power valve driver
NCA1042B	Automotive CAN FD transceiver	CAN communication network
NCA1051A	Automotive CAN FD transceiver	CAN communication network
NCA1043B	Frame-awaken Automotive CAN FD transceiver	CAN communication network
NCA1145	Local-awaken Automotive CAN FD transceiver	CAN communication network
NSM2011/13/15	Hall current sensor	PTC current detection

Distributed SoC solution for Thermal Management System

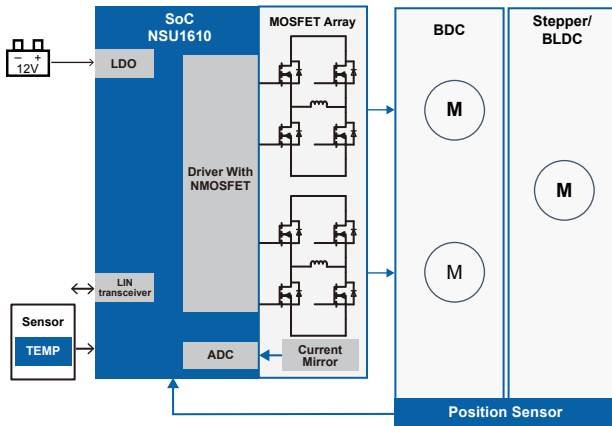

Centralized Solution for Thermal Management System

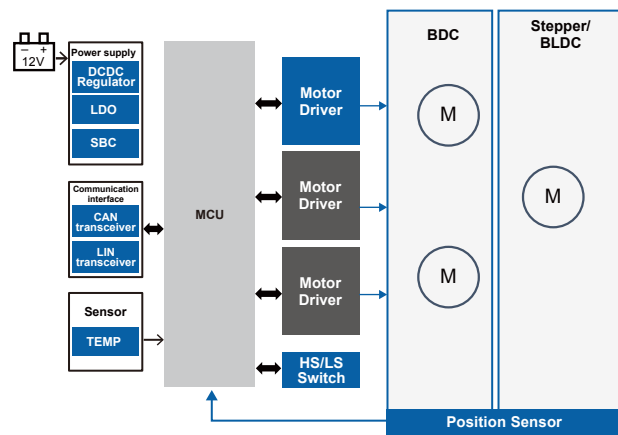

NOVOSENSE Part Number	Product	Application
NCA1021S-Q1	Supports INH wake-up LIN transceiver	Automotive general
NCA1042B	Automotive CAN FD transceiver	CAN communication network
NCA1051A	Automotive CAN FD transceiver	CAN communication network
NCA1043B	Frame-awaken automotive CAN FD transceiver	CAN communication network
NCA1145	Local-awaken automotive CAN FD transceiver	CAN communication network
NSD8308-Q1	40V 8-channel half-bridge driver	Domain controller, A/C controller
NSD8306/8/10/12-Q1	40V 6/8/10/12-channel half-bridge driver	Domain controller, air conditioning controller
NSD8381-Q1	40V 1/32 microstepping driver	Domain controller, air conditioning controller, electronic expansion valve
NSUC1610	Integrated LIN and Power MOSFET array, Automotive motor controller processor with 12V battery directed powered for 20W below BDC/BLDC/Step Motor	TMS Electrical valve
NSUC1602	Integrated LIN and MOS pre-driver, automotive motor controller processor with 12V battery directed powered for 1500W below BDC and BLDC Motor	TMS Electrical pump
NSR35/33/31xxx-Q	500mA/300mA/150mA 40-V, Low Iq	Automotive
NSR114xx-Q1	40V .6A/1.5A/2.5A/3.5A/5A/6A low power consumption/low EMI/synchronous buck DC-DC	Automotive
NSE11409-Q1	40V 90mohm single channel low-side drive	Relay/Solenoid valve/Load switch
NSE34050S/D/Q-Q1	40V 50mohm single/dual/four channel high-side drive	Relay/Solenoid valve/Load switch
NSM3011/12	Hall based angular sensor	TMS Electrical valve
NSM101X	Hall Switch/Latch with fixed sensitivity or user programmable	TMS Electrical valve and pump

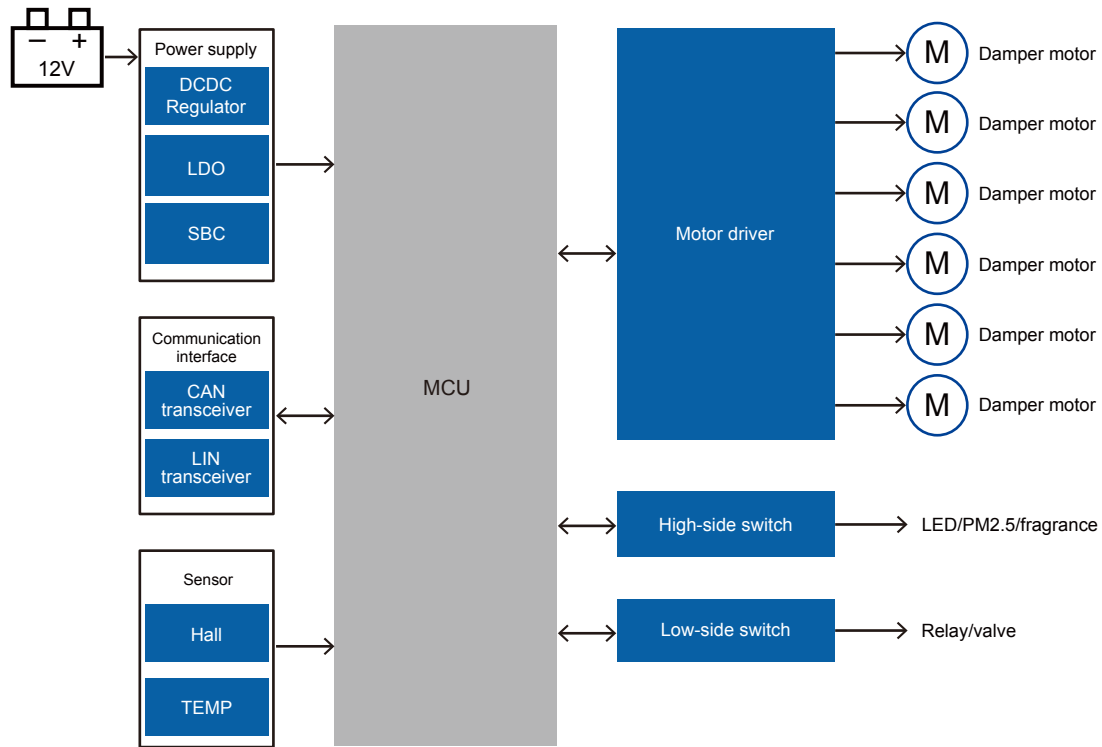

NOVOSENSE Part Number	Product	Application
NCA1021S-Q1	Support INH to wake up LIN transceiver	Universal for Automotive
NCA1042B	Automotive CAN FD transceiver	CAN communication network
NCA1051A	Automotive CAN FD transceiver	CAN communication network
NCA1043B	Frame-awaken automotive CAN FD transceiver	CAN communication network
NCA1145	Local-awaken automotive CAN FD transceiver	CAN communication network
NSD8306/8/10/12-Q1	40V 6/8/10/12-channel half-bridge driver	Domain controller, air conditioning controller
NSD8381-Q1	40V 1/32 microstepping driver	Domain controller, air conditioning controller, electronic expansion valve
NSR35/33/31xxx-Q1	40V 500mA/300mA/150mA 40-V, Low quiescent current LDO	Universal for automotive
NSR114xx-Q1	40V .6A/1.5A/2.5A/3.5A/5A/6A low-power/ low EMI Synchronous Buck DC-DC	Universal for automotive
NSE11409-Q1	40V 90mohm single-channel low side driver	Relay/solenoid valve/load switch
NSD12409-Q1	40V 90mohm dual-channel low-side driver	Relay/solenoid valve/load switch
NSD11/12416-Q1	40V 160mohm single/dual-channel low-side driver	Relay/solenoid valve/load switch
NSE34050S/D/Q-Q1	40V 50mohm single/dual/four-channel high-side driver	Relay/solenoid valve/load switch



Automotive LED Driver Solution

Rear light block diagram

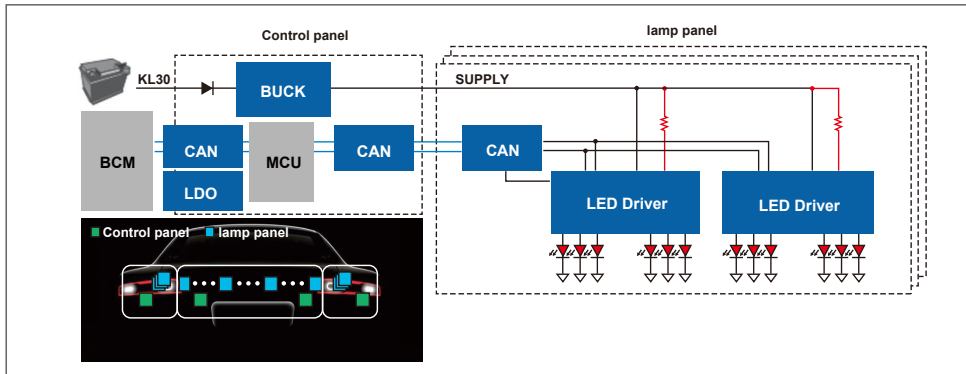

Front light block diagram

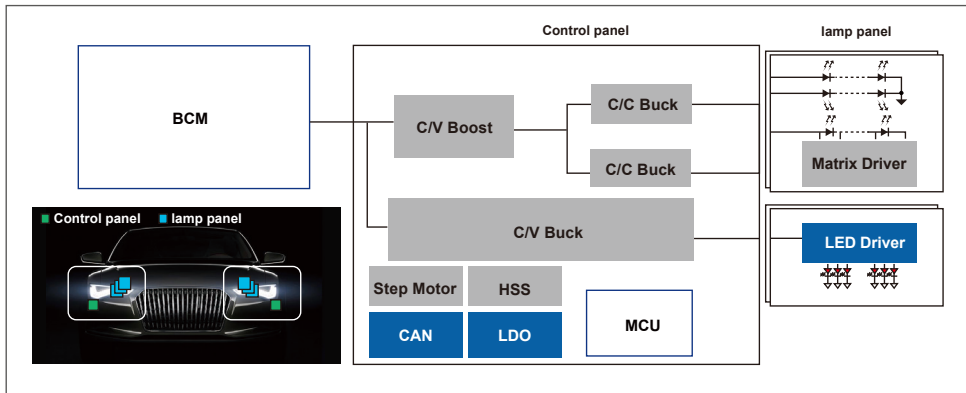

NOVOSENSE Part Number	Product	Application
NSL2161x	1CH linear LED driver	Rear light driver, width light driver
NSL2163x	3CH linear LED driver	Rear light driver, width light driver
NSL2363x	3CH linear LED driver	Rear light drive, width light driver
NSL21912	12CH through rear light LED driver	Through rear light
NSR31/3/5xxx	40V low power LDO	MCU power supply
NCA1021S-Q1	Supports INH wake-up LIN transceiver	Automotive general
NCA1042B	Automotive CAN FD transceiver	CAN communication network
NCA1051A	Automotive CAN FD transceiver	CAN communication network
NCA1043B	Frame-awaken automotive CAN FD transceiver	CAN communication network
NSE34050	High-side switch	Relay control

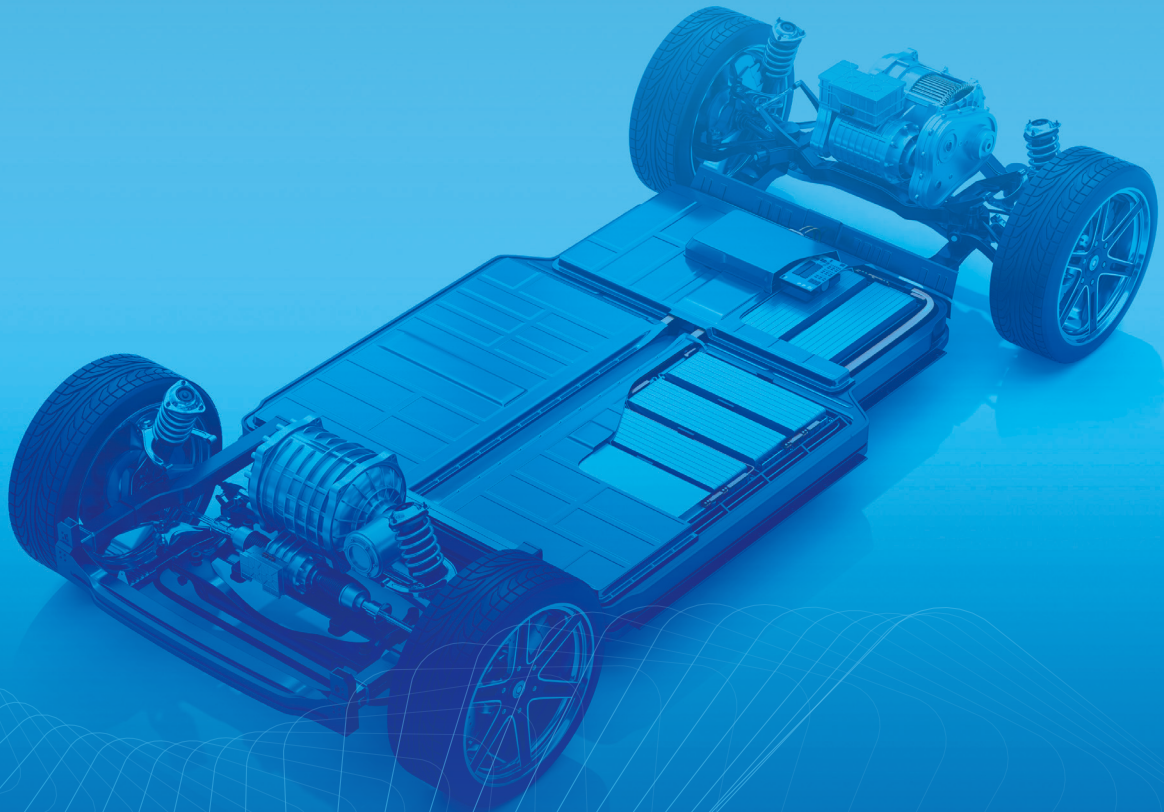

Body Control Module (BCM)

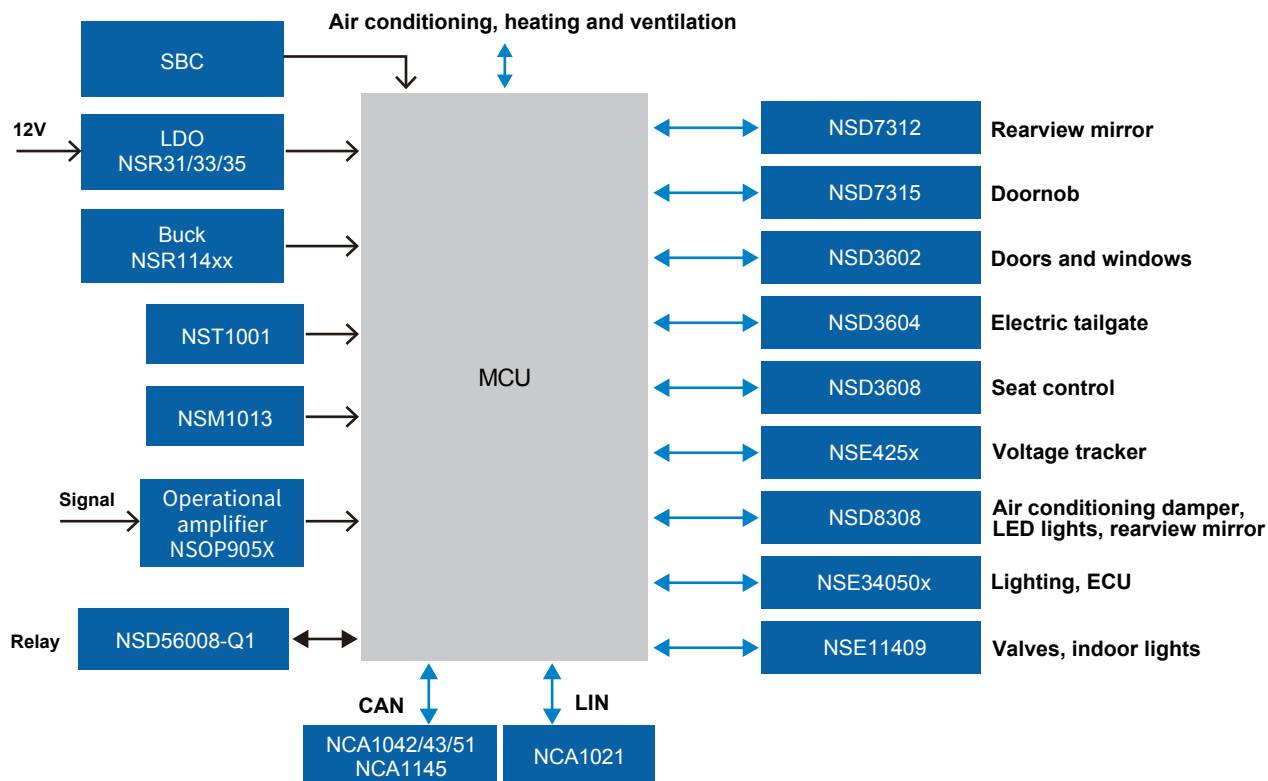

NOVOSENSE Part Number	Product	Application
NSD731x	40V brush DC motors	Body control
NSD8308	8-channel bridge drive	Air conditioning damper, rearview mirror
NSD360x	Multi-channel half-bridge pre-driver	Seat control
NSE34050x	1/2/4-channel high side switch	Lighting, ECU
NSD11409	Single-channel low side switch	Relay, valve
NSD12409-Q1	40V 90mohm dual-channel low-side driver	Relay/solenoid valve/load switch
NSD11/12416-Q1	40V 160mohm single/dual-channel low-side driver	Relay/solenoid valve/load switch
NSD56008	8-channel low side switch	Relay, valve
NSR31/3/5xx	40V 150/300/500mA LDO	Dashboard, in-board charging, body controls
NSR114x	40V 2.5/3.5/5/6A BUCK	Instrument panel, body control
NSE425x	Voltage tracker	Sensor power supply
NSM1013	Hall Latch	Seat control
NST1001	Temperature sensor	Temperature detection
NSOP905x	High voltage operational amplifier	Body control
NCA1042B	CAN FD transceiver	CAN communication
NCA1021S	LIN transceiver	LIN communication

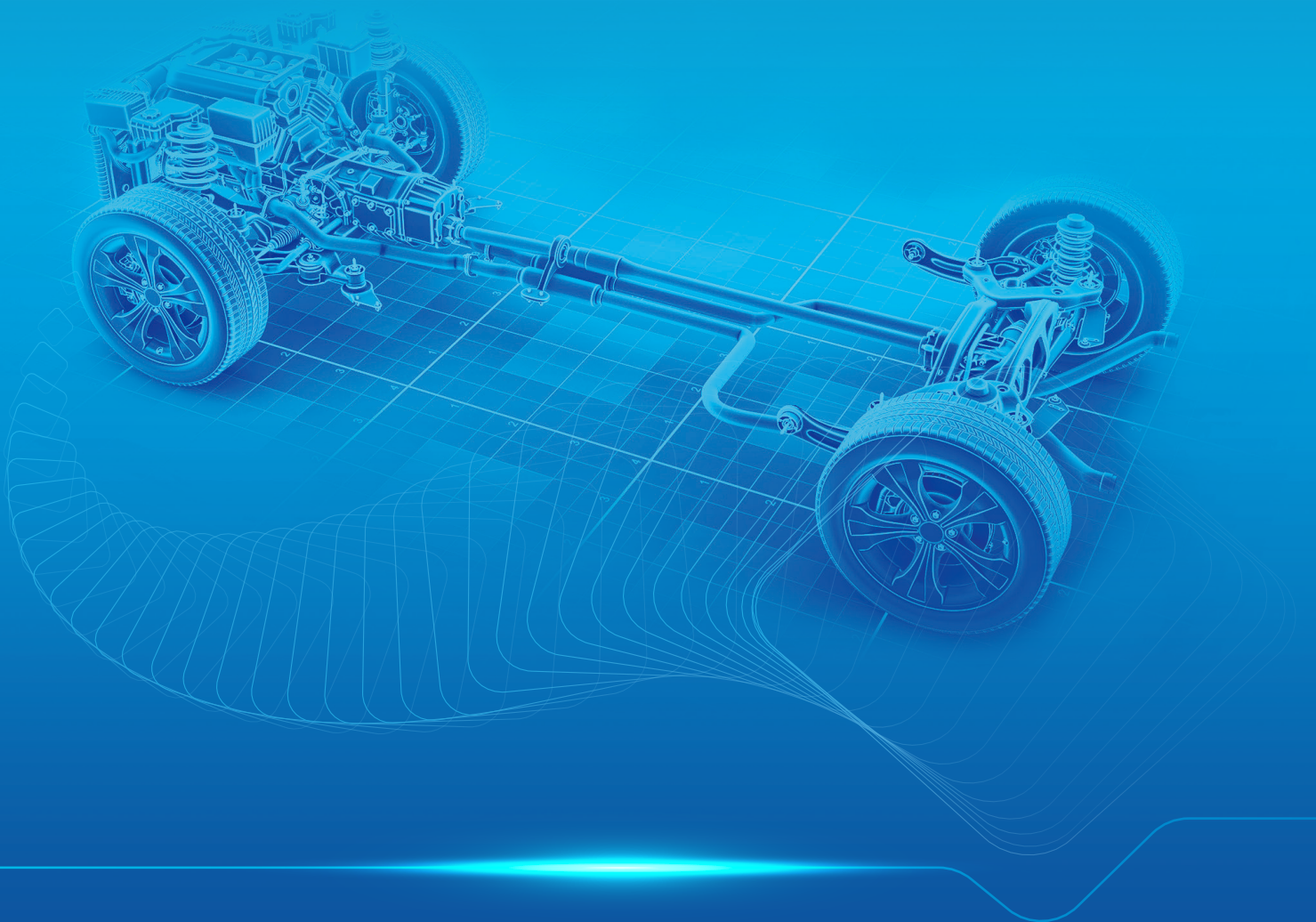

Fuel Powertrain & Fuel Supply System Solution

NOVOSENSE Solution

1. Intake manifold pressure sensor
2. EGR-TMAP pressure sensor
3. Throttle position sensor
4. Accelerator pedal position sensor
5. Positive crankcase ventilation pressure sensor
6. Oil pressure sensor
7. Oil tank level detection sensor
8. EVAP/FTPS pressure sensor
9. Canister desorption pressure sensor
 - Pressure sensor IC: NSPAS1, NSPAS3
 - Pressure sensor MEMS: NSP1630/1, NSP1632(Pt)
 - Signal conditioning ASIC: NSA/C9260X(analog), NSA/C9264(SENT)
10. GPF/DPF differential pressure sensor
11. EGR valve differential pressure sensor
 - Pressure sensor module: NSPGM1, NSPGM2, NSPDC1
 - Pressure sensor MEMS: NSP1831, NSP1832(Pt)
 - Signal conditioning ASIC: NSA/C9260X(analog), NSA/C9264(SENT)
12. Exhaust gas circulation valve position sensor
 - Magnetic angle sensor IC: NSM3011/12
13. VBS Vacuum boost pressure sensor
 - Pressure sensor IC: NSPAS1, NSPAS3
 - Pressure sensor module: NSPGM1, NSPGM2
 - Signal conditioning ASIC: NSA/C9260X(analog), NSA/C9264(SENT)
14. Brake pressure sensor
 - Signal conditioning ASIC: NSA/C9260X(analog), NSA/C9264(SENT)
15. ECU atmospheric pressure sensor (BAP)

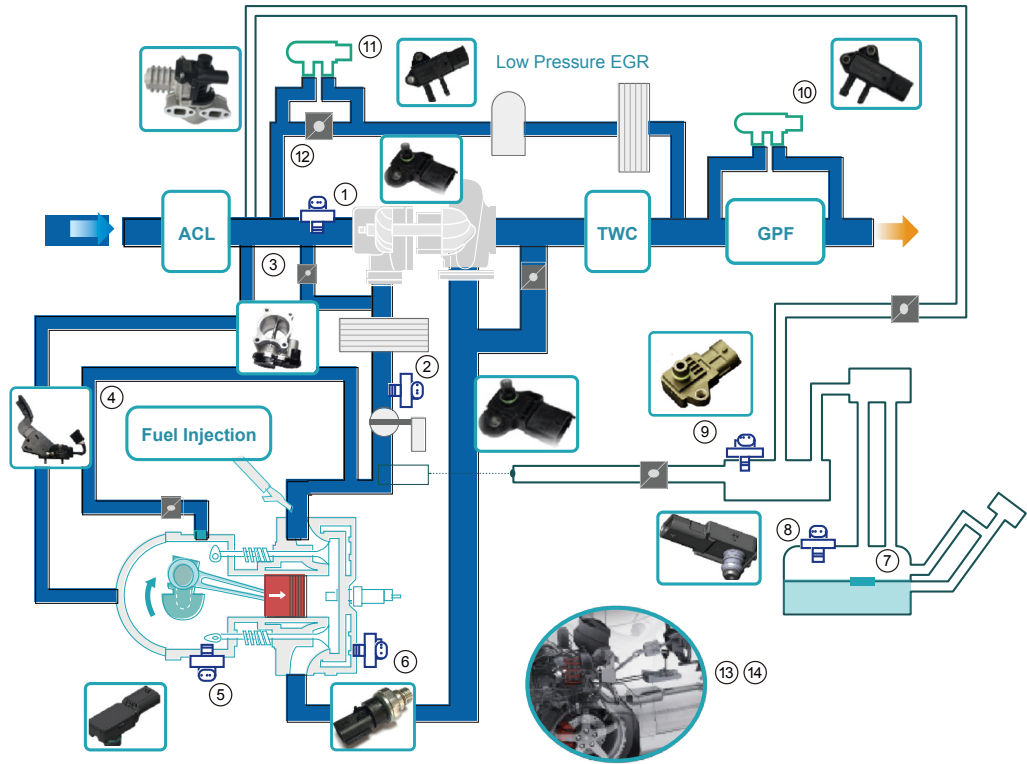

NOVOSENSE Part Number	Product	Application
NSPAS1/3	Absolute pressure sensor	TMAP, VBS, Canister desorption
NSPGM1/2	Differential pressure sensor	FTPS, KPS, GPF, VBS, EGR valve
NSPDC1	Differential pressure sensor	GPF/DPF, EGR valve
NSM3011/12	Hall angle sensor	EGR valve, throttle, accelerator pedal, oil level detection
NSA9260x	Pressure sensor resistive conditioning ASIC (analog output)	Oil/brake pressure, TMAP, VBS, Canister desorption, FTPS, KPS, etc
NSA9264	Pressure transducer resistive conditioning ASIC (SENT output)	Oil/brake pressure, TMAP, VBS, Canister desorption, FTPS, KPS, etc
NSC9260x	Pressure sensor capacitive conditioning ASIC (analog output)	A/C pressure, oil/brake pressure, TMAP, VBS, Canister desorption, FTPS, KPS, etc
NSC9264	Pressure sensor capacitive conditioning ASIC (SENT output)	Oil/brake pressure, TMAP, VBS, Canister desorption, FTPS, KPS, etc
NSC9262	Pressure sensor capacitive conditioning ASIC (LIN output)	A/C pressure
NSP1630/1	Absolute pressure MEMS wafer	TMAP, VBS, Canister desorption
NSP1632	Precious-metal absolute pressure MEMS wafer	TMAP, VBS, Canister desorption, EGR-Turbo
NSP1830/1	Differential pressure MEMS wafer	FTPS, KPS, GPF, VBS
NSP1832	Precious-metal differential pressure MEMS wafer	FTPS, KPS, GPF/DPF, VBS, EGR valve
NSE425x	Voltage tracker	Sensor power supply

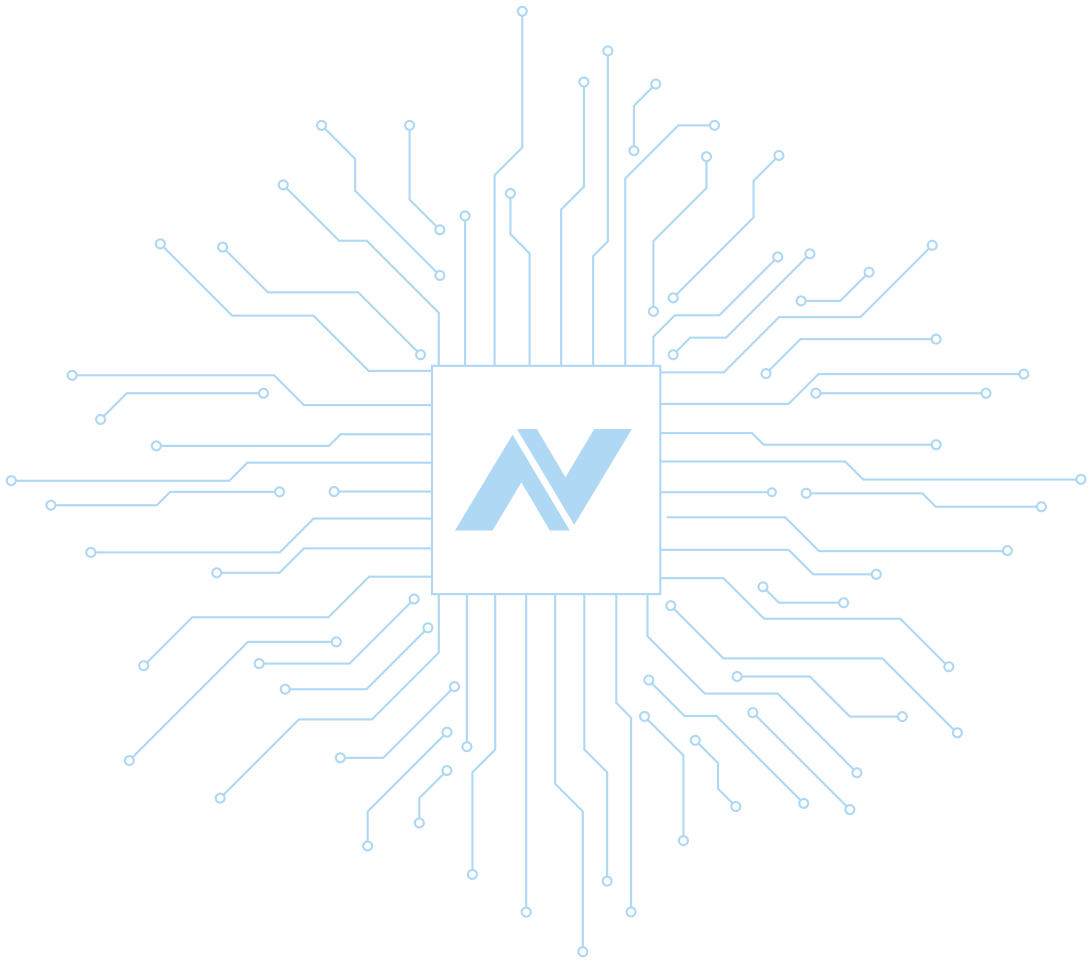

NOVOSENSE



NOVOSENSE
Company Brochure



Follow Us on WeChat



Find Jobs at NOVOSENSE



NOVOSENSE
Product Selection Guide



NOVOSENSE
Automotive Solution



NOVOSENSE
PV, Storage and EV
Charger Solution



NOVOSENSE
Industrial
Control Solution

NOVOSENSE Microelectronics

 [NOVOSENSE Microelectronics](#)

 sales@novosns.com

 0086-0512-62601802

 www.novosns.com

Release Date: December 2023